

Narrow-Track Agricultural Tractors: A Survey on the Load of the Hand-Operated Foldable Rollbar

D. Pessina, D. Facchinetti, D. M. Giordano

ABSTRACT. *To protect the driver in case of a tractor overturn, narrow-track tractors (used in vineyards and orchards) can be equipped with a rollover protective structure (ROPS) consisting of a two-pillar front-mounted foldable rollbar. The transition from the horizontal (rest) to the vertical (protection) position of this ROPS is performed manually by the driver. In addition to the time spent performing this task many times each day, a moderate physical load is required, given that these rollbars often have a mass of some tens of kilograms. In practice, neglect and poor attention to safety lead to the foldable rollbar remaining continuously in the rest position rather than being moved to the vertical (protection) position. Several rollover accidents have been fatal for the driver because the tractor, although equipped with a two-pillar front-mounted ROPS, had the rollbar in the horizontal position at the time of the event, thus assuring no protection to the driver. This issue is quite serious. To remove at least one of the problems for the proper management of this type of ROPS, the OECD has recently updated its Code 6 by introducing an optional test addressing the manual handling of front-mounted rollbars, providing a maximum load of 100 N. Several tests were conducted on new rollbars to ascertain the accuracy of this limit. The 100 N value was generally exceeded, which is cause for criticism. Indeed, a more appropriate reference for manual handling in this case would be the higher loads (up to 250 N) already provided by other standards for non-continuous tasks.*

Keywords. *Front-mounted ROPS, Raising force, Tractor overturning.*

Since the 1950s, the most frequent type of accident with agricultural tractors has been overturning. The resulting injuries can be prevented with some success by fitting rollover protective structures (ROPS), combined with the use of a driver's seatbelt. In many countries, authorities have imposed this type of protection on tractors for many years (Springfeldt, 1996). The Scandinavian countries were the first countries to issue mandatory regulations, with encouraging results. In Sweden, the frequency of fatal rollovers per 100,000 tractors per year decreased from 17 to 0.3. In Norway, the frequency of fatal rollovers decreased from 24 during 1961-1969 to 4 during 1979-1986. In Finland, the frequency of fatal rollovers decreased from 16 to 9 from 1980 to 1987. Moreover, from 1961 to 1986, the frequency of fatal rollovers in West Germany decreased from 6.7 to 1.3.

Submitted for review in December 2015 as manuscript number JASH 11709; approved for publication as part of the Tractor ROPS and Stability Research Collection by the Ergonomics, Safety, & Health Community of ASABE in June 2016.

The authors are **Domenico Pessina**, Full Professor, **Davide Facchinetti**, Researcher, and **Davide Maria Giordano**, Doctoral Student, Department of Agricultural and Environmental Sciences, University of Milan, Italy. **Corresponding author:** Domenico Pessina, DiSAA, 2-I Via Celoria, 20133 Milan, Italy; phone: +39-02 503-16876; e-mail: domenico.pessina@unimi.it.

Many of the accidents occurring during agricultural activities are not officially recorded for many reasons. A comparative study of 388 fatal accidents related to agricultural machinery that occurred in Spain from 2005-2010 concluded that only 61.9% of deaths were regularly reported. Based on 272 reported fatal overturn accidents, the main cause of death was the lack of a ROPS on the tractor; only one fatality involved a tractor that was equipped with a homologated ROPS (Arana et al., 2010).

In Italy, ROPS have been mandatory on new conventional tractors (with a minimum track width of 1150 mm on at least one of the axles) since 1974. In subsequent decades, this requirement has been gradually extended to other tractor categories. In particular, so-called “narrow-track” tractors (frequently used in vineyards and orchards) have been required to have ROPS since the mid-1980s. The strength of the ROPS is verified using a series of loading tests, which are specified in dedicated standards issued by international organizations (EU, OECD, ISO, and SAE) (OECD, 2016).

Starting from an official figure of 200 fatalities in the early 1970s, the Italian National Institute for Insurance against Accidents at Work (INAIL) currently reports that an average of 25 to 30 deaths per year are caused by overturns of agricultural tractors. Surveys from different sources reveal a considerably higher number of fatalities (Pessina and Facchinetti, 2011). This large discrepancy is attributed to the idea that compensation for injuries (fatal or nonfatal) is typically reserved to so-called “professionals”. However, in agriculture, the operation of tractors on a secondary basis by an extensive variety of non-professional workers is common. The official method of recording, classifying, and managing these events produces dynamics that do not facilitate prompt and updated monitoring on a national scale. The internet has changed the approaches used to communicate information. Many international, national, and local portals have been established to systematically report relevant news (BlogSpot, 2014, Caduti sul lavoro [Job victims]). Thus, a fatal accident at work, such as a tractor overturn with one or more victims, does not go unnoticed, even if it is not mentioned by the press at a national level, because it is reported on local web portals (of regions, municipalities, local TV, newspapers, and news sites) and on numerous blogs.

In 2008, some of the authors began observing the fatalities due to agricultural tractor overturns by examining many web portals for news and information (Pessina and Facchinetti, 2011; Pessina et al., 2015). The maximum detail level was extracted from each portal and used to construct a truthful, effective, and timely scenario of the situation. This approach has certain limitations; the values obtained do not completely reflect the real situation, and the details of the reported events are not completely congruent and may be subject to inaccuracies of the press. Notwithstanding these problems, the survey highlighted that in approximately 56% of these cases, the tractor had no ROPS (fig. 1). In 30% of the cases, the type of ROPS fitted was a two-post front-mounted foldable rollbar. Considering only the overturn accidents that involved tractors equipped with a two-post front-mounted foldable rollbar, the rollbar was determined to be in the horizontal position, which offers no protection, prior to the fatal event in 63% of the cases. This finding represents a critical situation that requires urgent countermeasures.

On narrow-track tractors, the rollbar is foldable to allow travel between vineyard and orchard rows without damaging the branches through entrapment with the ROPS pillars and/or to allow entry of the tractor into low garage doorways. For all other working tasks, the rollbar must be maintained in the vertical (protection) position.

The transition from the horizontal (rest) to the vertical (protection) position, and vice versa, of this type of ROPS is performed manually by the driver of the tractor. In addition

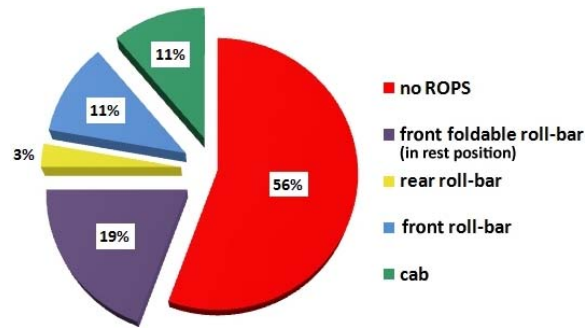

Figure 1. Types of ROPS fitted on agricultural tractors involved in fatal overturn accidents in Italy during the period 2008-2014 (from Pessina et al., 2015).

to the time required to perform this task multiple times per day, a moderate physical load is incurred because these rollbars often have a mass of some tens of kilograms. Thus, many of the reported rollover accidents involving tractors equipped with two-post front-mounted foldable rollbars were fatal for the driver because the tractor, at the time of the event, had the rollbar in the horizontal position, assuring no protection to the driver.

The main complaint regarding this problem is the excessive manual load required to manage the rollbar. To reduce and possibly solve this problem, the OECD recently introduced in Code 6 a new optional test that provides clear identification of a so-called “grasping area” on the rollbar pillars, defined by the manufacturer and designed for a standing operator to handle the rollbar manually (fig. 2).

Three accessible zones with different amounts of allowed force are defined with respect to the horizontal plane of the ground and the vertical planes tangent to the outer parts of the tractor, which limit the position or displacement of the operator (fig. 3):

Zone I: comfort zone.

Zone II: accessible zone without forward leaning of the body.

Zone III: accessible zone with forward leaning of the body.

Each measurement of the force necessary to raise or lower the rollbar must be made in a direction tangent to the trajectory of the rollbar and passing through the geometric center

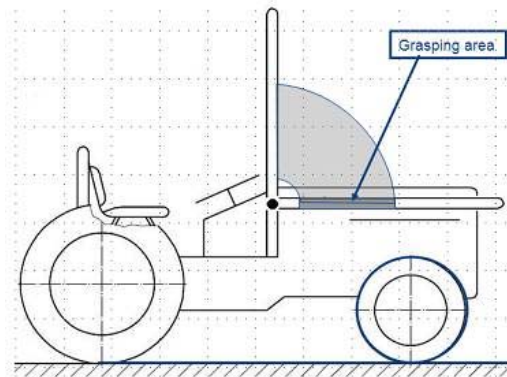

Figure 2. Detail of the so-called “grasping area,” designed for a standing operator to handle a two-pillar foldable front-mounted rollbar manually (OECD Code 6, 2016 edition).

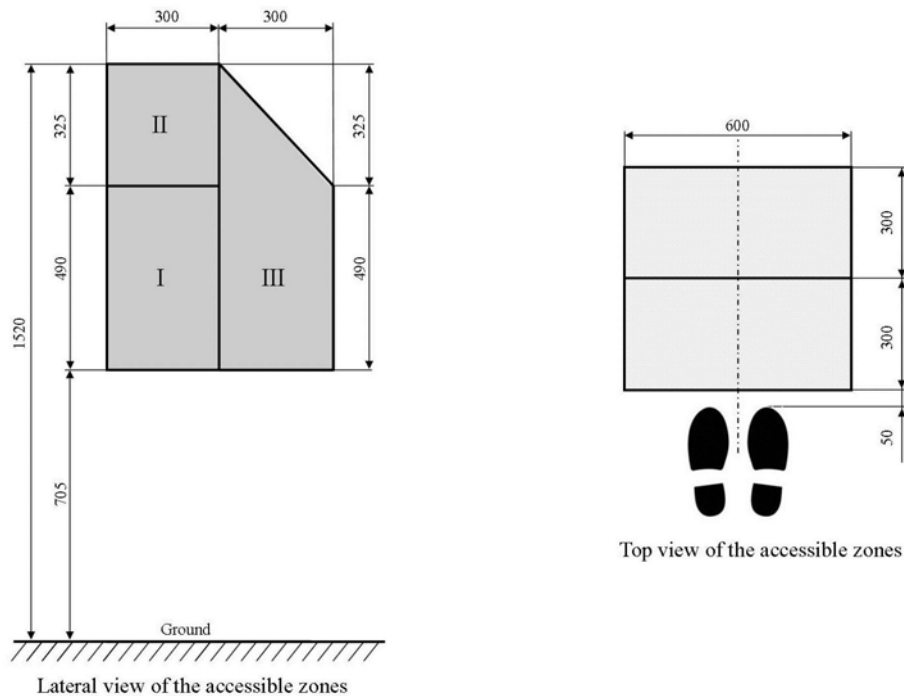

Figure 3. Dimensions of the three accessible zones for handling of foldable front rollbar (OECD Code 6, 2016 edition).

of the cross-section of the grasping area in a static condition. The force must be measured at different points within the accessible zone of the grasping area (fig. 4) The first measurement is performed at the extremity of the accessible part of the grasping area when the rollbar is fully lowered (point A). The second measurement is defined by the position of point A after rotation of the rollbar to the top of the accessible part of the grasping area (point A'). If, at the second measurement, the rollbar is not fully raised, an additional point must be measured at the extremity of the accessible part of the grasping area when the rollbar is fully raised (point B). Moreover, if, between the first two measurements, the trajectory of the first point crosses the boundary between zone I and zone II, a measurement must be made at this crossing point (point A''). To measure the force at the required points, it is acceptable either to measure the value directly or to measure the torque needed to raise or lower the rollbar and then calculate the force. The force acceptable for the actuation of the ROPS depends on the accessible zone, as shown in table 1.

This study is designed to ascertain the real handling modes and loads of front-mounted foldable rollbars. The results are compared to the findings obtained by applying the new relevant measure recently introduced in OECD Code 6. An alternative solution is then proposed by adopting the most relevant load limits provided in ISO Standard 11228-1:2003.

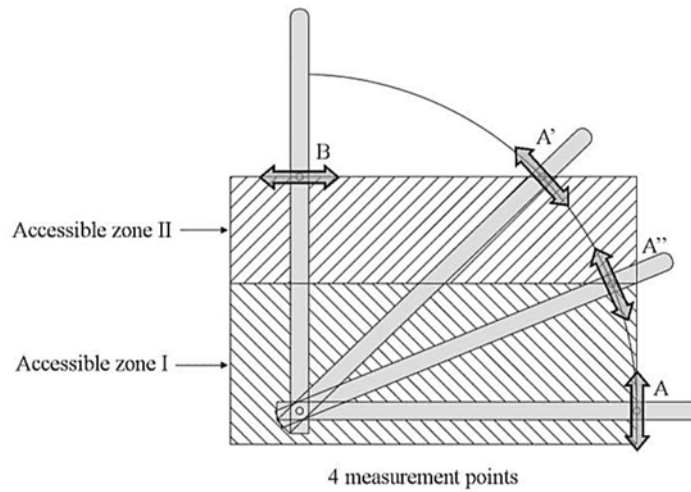

Figure 4. Sketch of the procedure to follow in measuring the forces required for handling the rollbar (OECD Code 6, 2016 edition).

Table 1. Maximum actuation force values provided by OECD Code 6, depending on the different accessible zones (OECD Code 6, 2016 edition).

	Zone I	Zone II	Zone III
Acceptable force (N)	100	75	50

Materials and Methods

Some preliminary tests were conducted by strictly following the procedure described in OECD Code 6. During execution of these tests, it was ascertained that, as expected, the operators very often start to raise the rollbar from the horizontal position by grasping it at its absolute top, not at the top of the defined grasping area (i.e., 1520 mm from the ground). Therefore, the static raising force values were also measured at the top of the foldable part of the rollbar when lying in the rest (approx. horizontal) position and, for some of the 19 tractors investigated, in five other significant positions (always tangent to the trajectory). These conditions correspond to angles of 0°, 30°, 45°, 60°, and 90° with respect to the horizontal plane, always at a distance of 1520 mm from the ground when the rollbar is in the vertical (protection) position (fig. 5).

Nineteen new narrow-track agricultural tractors were examined. All 19 were equipped with a front-mounted two-post foldable rollbar, with the mass of the foldable part varying from 8 to 49 kg. Of the 19 tractors investigated, ten were traditional wheeled, seven were isodiametric wheeled, and two were tracked.

In theory, on the basis that the heavier the tractor is, the stronger the rollbar must be, the tractor/rollbar mass ratio should be fairly constant. On the contrary, the results show significant variability, with this ratio ranging from 57.6 to 111.8 because the sections of the rollbar are often manufactured with different overall thickness and stiffness, usually obtained through the insertion of tubes and solid sections within the external tubes.

To measure the force values, an integrated load cell with a digital display was used (Macmesin model AFG 500 N) with a full scale of 500 N (plus an overload capacity of 50%) and

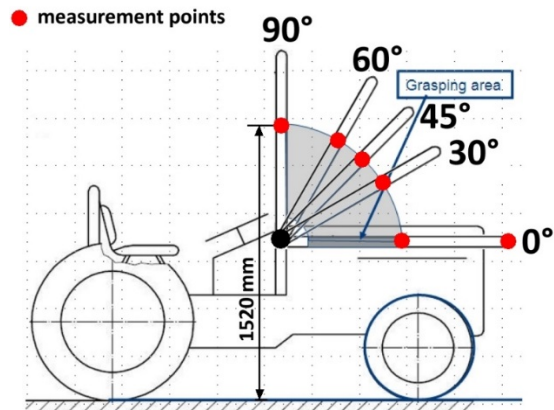

Figure 5. Measurement point locations and angles of inclination of the rollbar at which the raising force was measured.

a reading sensitivity of 0.01 N. To measure the inclination angle, a digital inclinometer (Lucas AngleStar) was used, with a reading sensitivity of 0.1° (fig. 6). For each tractor-rollbar combination, the tests were repeated at least three times to determine the variability.

In addition to the new optional test recently introduced into OECD Code 6, ISO Standard 11228-1:2003 was considered (ISO, 2003). This standard considers the intensity, fre-



Figure 6. Static raising test (A = integrated load cell with digital display; B = digital inclinometer).

quency, and duration of manual lifting and carrying of loads. The lifting condition in Annex C of ISO Standard 11228-1 that appears to be most similar to rollbar raising is a limit of 25 kgf (approx. 250 N) for a non-repetitive task (frequency of less than once per minute) for the adult working population and professional use. If these parameters are correctly applicable to the action considered in this case, it is stated that the average amount of the population protected is 85% (95% of males and 70% of females). Moreover, considering that the operators working in agriculture (particularly the operators driving and managing agricultural machinery) are 99% males, it is concluded that 250 N may be appropriate as a suitable limit. For this reason, the results were compared to both limits (100 N from OECD Code 6, and 250 N from ISO 11228-1).

Results and Discussion

Figure 7 shows the raising force values recorded at the top and at a height of 1520 mm from the ground for all 19 tractors examined when the rollbar was in the rest (horizontal) position, i.e., at a conventional 0° angle. In some cases, the rest position varied by 8° to 10° above or below the horizontal line due to different design solutions to minimize the obstruction of the driver's view by the rollbar, considering the hood contour. This parameter could have affected the initial raising force value, but in all cases a good simulation level was ensured in measuring the real operator's load.

At a height of 1520 mm from the ground, all the force values obtained exceeded the 100 N limit, including the value for tractor 16, on which the rollbar was equipped with a pair of gas springs. In this case, the high value is probably due to the initial mechanical resistance presented by the gas spring in the extension of the rod. Considering the data obtained at the top of the rollbar, the limit was exceeded in 15 of the 19 cases (79%), but in some tests the recorded value was only slightly higher than 100 N.

Comparing the data to the limit of approximately 250 N (25 kgf) provided by ISO Standard 11228-1, the force was exceeded in only 12 of the 19 tests (63%) at a height of 1520 mm from the ground, whereas all of the values at the top of the rollbars were lower than 250 N. This is the first information on how the considered limit may strongly indicate the need to improve the rollbar handling (e.g., by fitting an aiding device).

Considering the typical handling of the rollbar, i.e., its rotation through an overall angle of approximately 90° with reference to the hinge point, a strong link between the rollbar mass and the raising force should be found. Unexpectedly, however, the results show a poor correlation between the two parameters (fig. 8). The raising force is affected not only by the rollbar mass (and of course the height of the foldable part) but also by the center of gravity of the rollbar and the friction of the pins on which the foldable part of the rollbar rotates. In some cases, the friction force reaches a remarkable value due to the limited tolerance between the diameters of the pins and the holes in which they are inserted.

Figure 9 shows the raising force trends measured at 1520 mm from the ground for inclination angles from conventional 0° to 90° for 8 of the 19 tractors examined. Although the force values are quite different, as expected, the maximum raising force was recorded at the horizontal position. Moreover, in many cases, the force tended to remain high until 30° inclination (starting from the horizontal) and then decreased remarkably for angle values greater than 30° . Gas springs (tractor 16) allowed a significant reduction of the raising force over the entire the rollbar extension range.

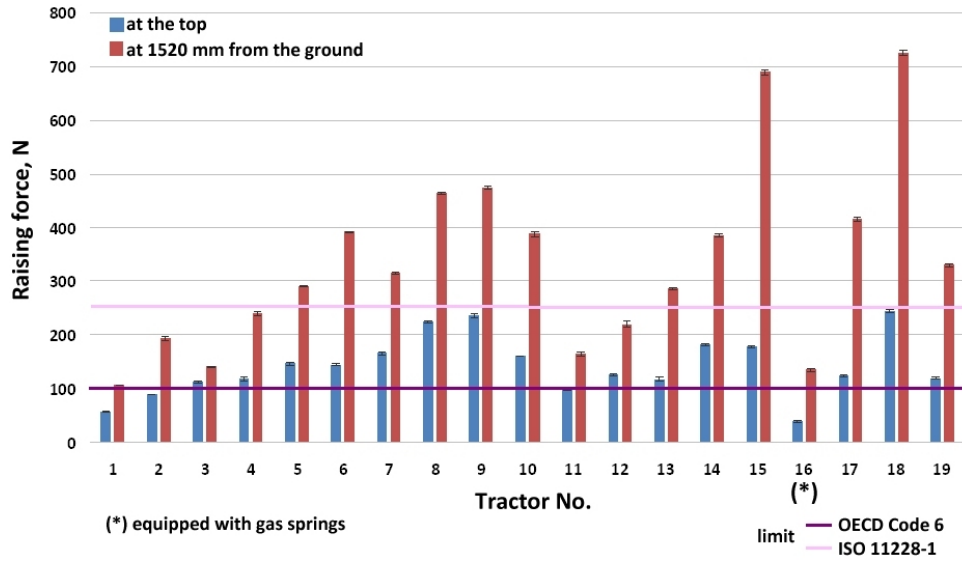

Figure 7. Raising force values of the investigated rollbars at the conventional 0° angle and at the top of the ROPS at a height of 1520 mm from the ground as provided in OECD Code 6 (1 to 10 = traditional wheeled tractors, 11 to 17 = isodiametric wheeled tractors, and 18 and 19 = tracked tractors).

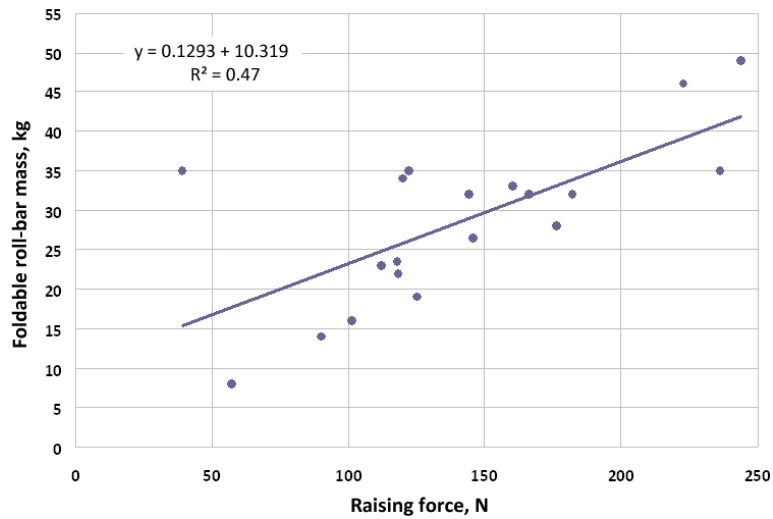

Figure 8. Comparison between foldable rollbar mass and corresponding raising force recorded at the top of the rollbar at the conventional 0°.

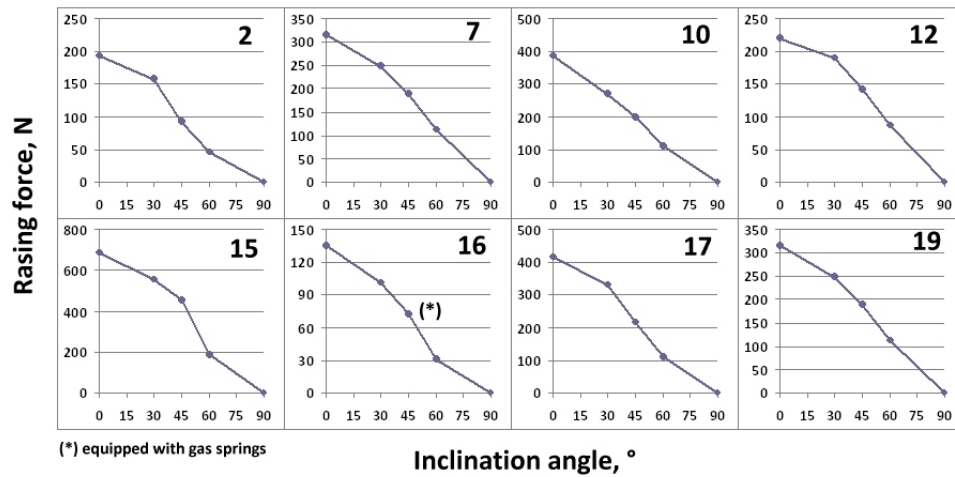

Figure 9. Raising force trends measured at 1520 mm from the ground for inclination angles from conventional 0° to 90° for 8 of the 19 tractors examined. Numbers refer to the tractors as listed in table 2.

Table 2. Type and mass of the tested tractors and their rollbars (foldable part).

Tractor Type	Tractor Number	Tractor Mass (kg)	Rollbar Mass (kg)	Tractor/Rollbar Mass Ratio
Traditional wheeled	1	840	8	105.0
	2	1460	14	104.3
	3	1475	23	64.1
	4	1850	22	84.1
	5	2230	26,5	84.2
	6	2280	32	71.3
	7	2540	32	79.4
	8	2650	46	57.6
	9	2710	35	77.4
	10	2865	33	86.8
Isodiametric wheeled	11	1100	16	68.8
	12	1235	19	65.0
	13	1770	23,5	75.3
	14	1940	32	60.6
	15	2360	28	84.3
	16	2410	35	68.9
	17	2410	35	68.9
Tracked	18	3480	49	71.0
	19	3800	34	111.8

Conclusions

In our opinion, the force limit of 250 N seems to be more appropriate than the 100 N value in OECD Code 6. In fact, 250 N is a value established in an ISO standard, distributed worldwide, for non-continuous tasks (of which rollbar handling is an example) and statistically validated for a high percentage (95%) of male operators, thus adequately representing the workforce in agriculture.

Although the data obtained in this survey are not exhaustive, the relevant trend is sufficiently clear, i.e., the 100 N limit is exceeded on all the rollbars at a height of 1520 mm from the ground. As a consequence, this limit can be satisfied only by fitting an aiding

device (e.g., gas springs or hydraulic cylinders). In contrast, the 250 N limit appears fully justified from an ergonomic perspective and allowed the handling of 7 of the 19 rollbars investigated without any supplementary mechanism. On the other hand, considering the ISO limit, an aiding device should be provided for the other 12 rollbars.

In our opinion, this approach could provide a well-balanced solution to the problem, effectively reducing the handling load required of the narrow-track tractor driver while at the same time avoiding difficulties in adapting many rollbars to an unjustified low force limit. The next step (already implemented by some manufacturers) is to avoid manual handling of the rollbar entirely by introducing different levels of automation. First, hydraulic cylinders could be fitted and activated manually, by means of a lever or a button; a further level could be full automation of the rollbar position depending on the occurrence of dangerous conditions (i.e., lack of or poor lateral and/or longitudinal stability).

In any case, a driver's seatbelt should be fitted and correctly fastened. In fact, if the operator is not safely fixed to the seat, it is quite possible that, especially in the case of a lateral overturn, the operator could be thrown out and fatally struck by the ROPS, the very device that should instead provide proper protection.

References

- Arana, I., Mangado, J., Arnal, P., Arazuri, S., Alfaro, J. R., & Jaren, C. (2010). Evaluation of risk factors in fatal accidents in agriculture. *Spanish J. Agric. Res.*, 8(3), 592-598.
<http://dx.doi.org/10.5424/sjar/2010083-1254>
- BlogSpot. (2014). Caduti sul lavoro [Job victims]. Retrieved from <http://cadutisullavoro.blogspot.com>
- ISO. (2003). ISO 11228-1:2003: Ergonomics - Manual handling - Part 1: Lifting and carrying. Geneva, Switzerland: International Standards Organization.
- OECD. (2016). OECD standard codes for the official testing of agricultural and forestry tractors. Paris, France: Organization for Economic Co-operation and Development. Retrieved from <http://www.oecd.org/tad/code/oecd-standard-codes-official-testing-agricultural-forestry-tractors.htm>
- Pessina, D., & Facchinetti, D. (2011). Il ruolo del web nel monitoraggio degli incidenti mortali dovuti al ribaltamento dei trattori agricoli. In *Convegno di Medio Termine dell'AIIA*. Rome, Italy: Associazione Italiana di Ingegneria Agraria.
- Pessina, D., Facchinetti, D., & Giordano, D. M. (2015). Narrow-track agricultural tractors: A survey on the load of hand-operated foldable roll-bar. In *Proc. Intl. Conf. on Rural Health and Ragusa SHWA: Safety Health Welfare in Agriculture Agro-food and Forestry Systems*. Catania, Italy: University of Catania.
- Springfeldt, B. (1996). Rollover of tractors: International experiences. *Saf. Sci.*, 24(2), 95-110.
[http://dx.doi.org/10.1016/S0925-7535\(96\)00069-0](http://dx.doi.org/10.1016/S0925-7535(96)00069-0)