

# **The Driver's Protection in Case of Self-Propelled Machinery Roll-Over**

**Domenico Pessina**

Department of Agricultural and Environmental Sciences (DISA)  
University of Milan, Via Celoria, 2, 20133 Milan, Italy

**Davide Facchinetti**

Department of Agricultural and Environmental Sciences (DISA)  
University of Milan, Via Celoria, 2, 20133 Milan, Italy

**Davide Giordano**

Department of Agricultural and Environmental Sciences (DISA)  
University of Milan, Via Celoria, 2, 20133 Milan, Italy

Copyright © 2015 Domenico Pessina et al. This article is distributed under the Creative Commons Attribution License, which permits unrestricted use, distribution, and reproduction in any medium, provided the original work is properly cited.

## **Abstract**

Despite a real risk of overturning, for the Self-Propelled agricultural Machinery (SPM) the ROPS approach to protect the driver is rather recent. Due to the several SPM categories available on the market, characterized by very different mass, dimension and working functions, the fitting of a ROPS and consequently the check of its strength is complicated.

The SPM could be preliminarily divided into at least two categories:

- large SPM: combine, forage, potato, sugar-beet and grape harvesters; sprayer; etc.;
- small SPM: ride-on tractor, mower, comb side-delivery rake, etc.

The most followed approach at present is to define preliminarily the overturning behaviour of the SPM, considering its longitudinal and lateral stability; if a real risk is detected, in order to minimize the likelihood of driver's injury the manufacturer often decides to install a ROPS. The consequent need is to provide some relevant test criteria.

Sprayers among large SPM, and comb side-delivery rake among small SPM were the machine types on which the ROPS were tested, adopting in both cases the procedure provided by Code 4 issued by the Organization for Economic and Cooperation Development (OECD), dedicated to ROPS fitted on conventional agricultural and forestry tractors.

On the sprayer having a mass of 4950 kg was fitted a closed cab, while on the comb side-delivery rake having a mass of 690 kg was applied a 3-pillars frame. The response was positive in both tests, so indicating a general suitability of OECD Code 4 to assure a ROPS good driver's protection level in case of overturning.

On the other hand, to ascertain more in detail the roll-over behaviour of the SPM, some further questions need to be deeply examined, such as the driver's place location, the height of the centre of gravity from the ground in different machine configurations (i.e. with product tanks empty or full), the external silhouette, the axles mass distribution of the laden/unladen machine, etc.

**Keywords:** self-propelled machinery, stability, overturning, roll-over protective structure

## 1 Introduction

The statistics reveal that not only the tractors can be subjected to a tip- or a roll-over, but also some other categories of small and large Self-Propelled agricultural Machinery (SPM) [Crandall *et al.*, 1997; Day, 1999; Arana *et al.*, 2010]. In any case, all mobile machinery is at risk of rolling over (depending on machine characteristics, working environment and terrain), and a risk assessment process should evaluate the probability of such an event occurring (**fig. 1**).



Fig. 1: The Self-Propelled agricultural Machinery are at risk of rolling over (courtesy of INAIL – Rome, Italy)

The roll-over protective systems have relied almost exclusively on surrounding the operator (the driver) by a frame or cab strong enough to absorb the impact energy of an overturning vehicle, without violating a volume referred to the probable driver's position, if he/she remains on his/her seat by means of a safety belt properly fastened. Depending on the various Standards, this volume is called Deflection Limiting Volume, Safety Zone, etc. The frame or cab fitted on the vehicle

is known as ROPS (Roll-Over Protective Structure). The strength of the ROPS is usually related to the mass of the vehicle, although different conditions apply in different sectors. Consideration must also be given to whether the protection is needed for a partial (i.e. 90°) or continuous roll-over [Stockton et al., 2002].

However, similar vehicles are currently tested referring to different Standards, according to the different purposes for which they are used. For example, the same chassis, engine and cab assembly might be finished and equipped for work in the construction, agricultural or forestry industries.

As more ride-on mobile machinery is being designed and developed for dedicated tasks (e.g. combine harvesters; grape, potato, sugar-beet, forage harvesters; sprayers, etc.), the interpretation and application of roll-over protection legislation is at present rather difficult, and in particular in the “amenities” sector, where in some cases the suitability of a ROPS fitting may be questioned.

Roll-over accidents with tractors, self-propelled harvesting machinery and materials handling machinery show similarities in terms of causes, circumstances and consequences, although they are quite different in vehicle concept, operation and use [Mayrhofer et al., 2014]. The rollover accidents are mostly influenced by the work tasks and the environmental conditions. Incorrect or inappropriate vehicle use by the driver and technical defects are also important causes.

On the other hand, an alternative approach is to define the suitability of the ROPS fitting on a given machine by means of the Finite Element Modelling and subsequent analysis [Karlinsky et al., 2013]. Among other several attempts, the maximum lateral force acting on a mower ROPS and the relevant energy absorbed during a lateral continuous roll-over were numerically predicted using elastic and plastic theories, including nonlinear relationships between stresses and strains in the plastic deformation range [Wang et al., 2009].

Moreover, the structures fitted at the driver's place of 5 different categories of self-propelled agricultural machines were analyzed with the goal of fitting ROPS with a strength level in accordance with the standards used for tractors, while maintaining the same shape and dimensions as the existing structure. An increase of the resistance of the materials and/or the thickness of the mountings was judged necessary [Molari et al., 2014].

To give an answer to the needs of the manufacturers in terms of operator's protection from the roll-over risk, in 2012 the OECD defined a priority list of SPM on which to study the problem, in the following order: 1) grape harvesters; 2) sprayers; 3) ride-on mowers; 4) low-mass machines [OECD doc. TAD/CA/T/WD(2012)7, 2012].

On the other hand, a recent approach of ISO was the development of the Standard ISO 16231 “Self-Propelled Machinery – Assessment of stability” (ISO 16231, 2013), consisting into two parts: 1) principles; 2) calculations and test procedures. In particular, part 1 examines the principles of a risk assessment to determine the rollover hazard for a specific machine, as follows:

1. intended use of the machine;
2. operation to be carried out;
3. typical operating and ground conditions (e.g. slope);

4. physical properties of the machine (masses, dimensions, etc.) under operating conditions;
5. operator (education, training).

The document then points out different protective measures to reduce the risk of rollover for the machine under consideration. Therefore, the machine could be:

1. designed with a Static Overturning Angle (SOA) higher than the required Static Stability Angle (which is the required calculated slope on which the stability of the machine must be guaranteed);
2. equipped with a self-protective device (attachment or device firmly fitted to the machine which prevent the machine from tip- or roll-over);
3. equipped with an automatic protective system (automatic system controlling functions of the machine to minimize the likelihood of);
4. provided with structures to assure an appropriate deflection limiting volume. They are called “Self Protective Structure”, being structural elements of the vehicle which will absorb energy during the tip- or roll-over, or ROPS/TOPS. In any case, when a manufacturer of SPM has decided to adopt the ROPS solution in order to minimize the likelihood of driver's injury, a Standard must be adopted in order to test the ROPS strength. In this view, in 2010 it was pointed out that OECD Code 8 procedure is more suitable for evaluating the strength performance of the ROPS retrofitted on the grape harvesters. However, the results demonstrated also some points where the testing procedures need to be modified in order to match the specific characteristics of the machinery considered [Capacci and Rondelli, 2010].

In detail, for **large SPM**, the problem of roll-over involves some technical characteristics and working conditions: high overall mass, including the content of large tanks fitted on board; high centre of gravity, in case the machine is working riding the crop (i.e. grape harvester and sprayer); development of high torque values; travelling on steep and rough slopes at high speed.

Also the **small SPM**, such as ride-on tractors, mowers, comb side-delivery rakes are subjected to possible roll-over, due in this case not to a large mass or to a high centre of gravity, but rather to the roughness of the ground on which they travel at high speed, leading to skidding and bumps causing the lack of the vehicle control, especially when working on slope during forage management operation.

Moreover, the location of the driver's place on the tractors compared with that of SPM is often quite different: on the conventional tractors the seat and the steering wheel are normally located in a central/rear position, lying them on the longitudinal centre line. On the contrary, on the SPM the driver's place is often located in extreme front or rear positions and sometime is not central in the lateral axis.

Moreover, especially for large SPM the so called “Self-Protective Structures (SPS)” have to be considered for an extra protection in case of overturning. As defined in ISO 16231-1, the SPS are *structural components of the machine, with*

sufficient strength to provide a deflection limiting volume if the machine overturns.

The SPS can be represented by tanks, frames, shields, carters, etc. normally fitted on the machine, providing a certain energy absorption in case of overturning, avoiding partially (or sometime completely) the mechanical stress to which the cab structure should be subjected. Thus, the mechanical features of these structural elements have to be defined by adopting one (or more) testing method(s), allowing to identify and assess their strength in a reliable and repeatable way.

This is not a new principle, because in some standards finalized to the testing of the ROPS to be fitted on earth-moving machinery [ISO 12117-2, 2010] some simulated ground planes are defined. Each of them is defined by at least 3 stiff points located on the machine (deriving from SPS), which can provide protection for the operator in case of impact with the ground during a machine tip- or roll-over. In case the operator seat is off the machine longitudinal centre line, the worst condition has to be considered. Thus, a lateral, front, rear and upper boundary simulated ground planes (named respectively LBSGP, FBSGP, RBSGP and UBSGP, **fig. 2**) can be identified (INAIL, 2013).

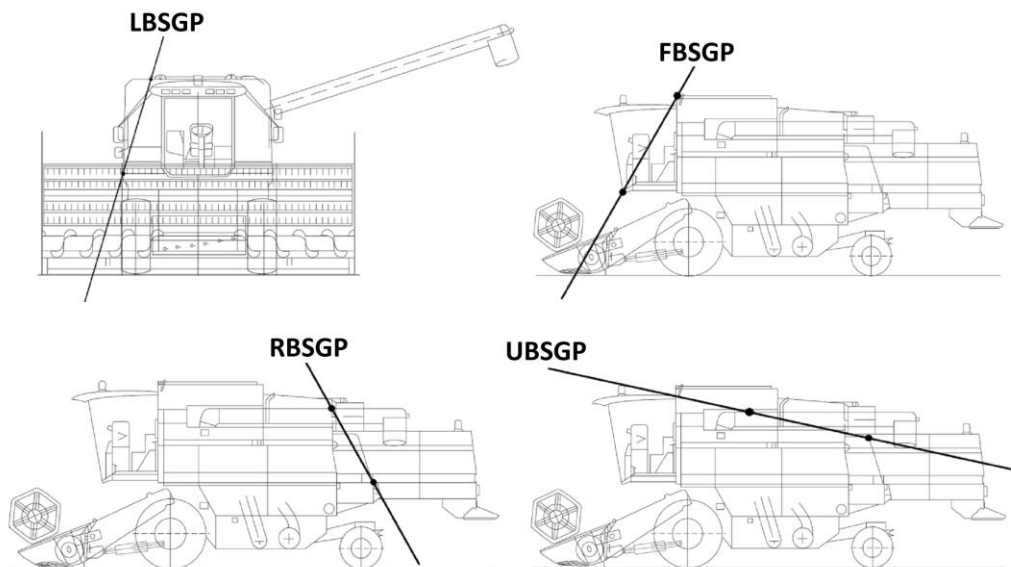

Fig. 2: Examples of lateral (LBSGP), front (FBSGP), rear (RBSGP) and upper (UBSGP) boundary simulated ground planes, referred to a combine harvester (courtesy of INAIL – Rome, Italy)

The stiff points are lying on rigid structural members that remain fixed and unchanged on the machine in any configuration (including working in field and transport conditions), showing adequate strength to support the induced loads during a tip- or roll-over resulting in predictable deformation. Shall not be considered as stiff points interchangeable or detachable devices, e.g. for combine

harvesters the header or the pick-up and stripping heads, and for grape harvesters detachable vine shoot tipping devices.

Some procedures have been proposed in order to test physically the strength of the stiff points. One of them provides to apply a static force equal to 67% of the machine weight in a perpendicular direction to the ground when the given point touches the terrain in case of overturning.

In any case, waiting for the issue of dedicated Standards, manufacturers asked with urgency for the testing of ROPS to be fitted on SPM, being it the most common (and quick) solution considered for the protection of the driver in case of tip- or roll-over.

In the first instance, the lack of dedicated Standards leads to the application of those already used for similar machinery, mainly agricultural and forestry tractors, and sometimes also earth-moving machines. On the subject, the OECD Code 4 appears at present the most known and applied standard (OECD Code 4, 2014), and the aim of this paper is to verify if OECD code 4 is suitable also to test the ROPS fitted on SPM.

## 2 Materials and method

In 2013 and 2014, on the ROPS rig located in the DISAA laboratory of the University of Milan (Italy) two tests were carried out, respectively on the ROPS fitted on a self-propelled sprayer (*large SPM*), and on a comb side-delivery rake (*small SPM*). The most important technical features of these two SPM (mainly their mass and front and rear track width) were inside of the range provided for the application of OECD Code 4.

In detail, on the self-propelled sprayer was fitted a 4-pillars closed cab; on the contrary, due to technical and economical reasons, a simple 3-pillars frame was provided for the comb side-delivery rake (**figs. 3 and 4**).

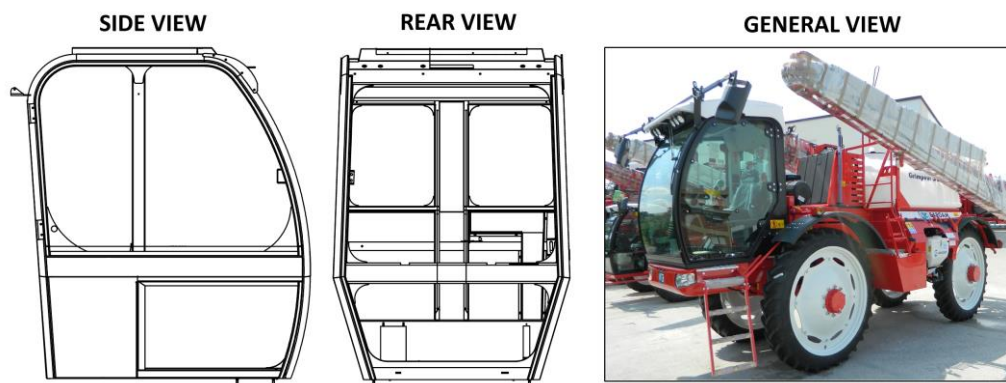

Fig. 3: General drawings (left) and view (right) of the ROPS fitted on the large SPM, a self-propelled sprayer

The OECD Code 4 provides a sequence of 4 tests; as shown in **table 1**, depending on the provided formulae defined energies (E, in J) are absorbed and defined forces (F, in N) are applied, relevant to the machine mass (M, in kg).

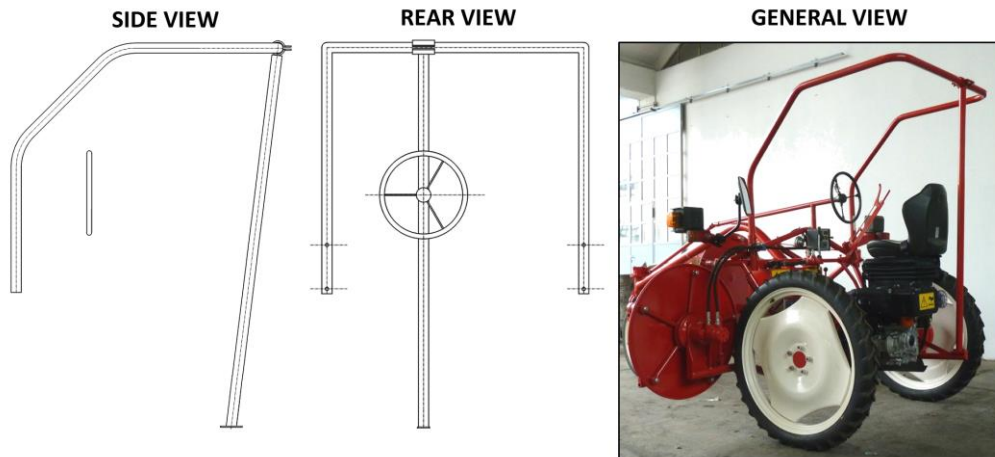

Fig. 4: General drawings and view of the ROPS fitted on the small SPM, a comb side-delivery rake

Tab. 1: Tests sequence and formulae provided in OECD Code 4 for testing ROPS to be fitted on agricultural and forestry tractors.

Test sequence	Loading	Formula
1	rear horizontal	$E = 1.4 M$
2	rear vertical	$F = 20 M$
3	side horizontal	$E = 1.75 M$
4	front vertical	$F = 20 M$

E = energy, J; F = force, N; M = machine mass, kg

The machine mass appears a key feature on which are based the energies to be absorbed and the forces to be applied.

On the SPM that are not harvesting or collecting nor distributing any material is easy to define a reference mass. On the contrary, the cases of combine and grape harvesters, as well as the self-propelled sprayers, are more complicated, due to large mass variation occurring in the conditions of tank(s) empty or full. In such cases, the mass increases remarkably, up to 50% or more.

Moreover, the tanks can be open or closed: in the first case, in the event of an overturning, all (or part) of the material could escape outside, thus decreasing the mass of the machine and the stress on its structure when impacting the ground.

On the other hand, no mass variation could occur in case of closed tank(s), but attention should be paid to the attachment of the tank(s), considering a possible complete detachment from the machine frame.

In **table 2** the main technical characteristics of the two SPM are shown, as far as the energies to be absorbed and the forces to be applied.

Tab. 2: Minimum values of energy to be absorbed and force to be applied to the ROPS fitted on the two SPM

Test sequence	Self-propelled sprayer ( $M_{ref} = 4950$ kg min track = 1800 mm wheelbase = 2820 mm)	Comb side-delivery rake ( $M_{ref} = 690$ kg min track = 1340 mm wheelbase = 2440 mm)
1	E = 6.93 kJ	E = 0.97 kJ
2	F = 99.0 kN	F = 13.8 kN
3	E = 8.66 kJ	E = 1.21 kJ
4	F = 99.0 kN	F = 13.8 kN

### 3 Results and discussion

Because cabs and frames are normally manufactured with vertical pillars, in the major part of the ROPS tests the horizontal loadings (to the rear and then to the side in the case of OECD Code 4) result more severe rather than those applied vertically.

This is because when applying the vertical tests the pillars are loaded in the direction of maximum resistance; on the contrary, in the horizontal axes the structural components are loaded in their weakest section. Also in the two tests of ROPS fitted on SPM this condition has been verified, and as a consequence only the horizontal loadings have been investigated in detail.

In **figs. 5 and 6** are shown the Force-Deflection (F-D) curves and the view at the end of the rear and side loadings of the ROPS fitted on the two SPM under consideration. On the basis of the F-D curves, the values of permanent and elastic deflection were calculated, comparing them with the total deflection value.

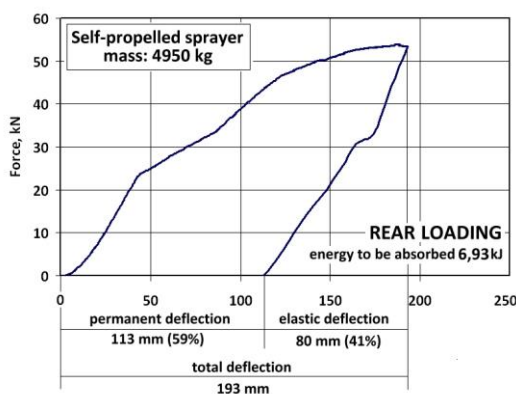



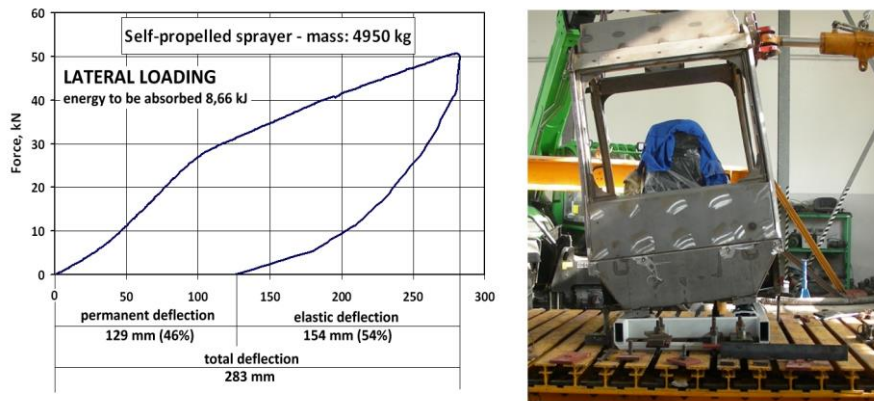

Fig. 5: Force-deflection curves and condition at the end of the rear and side loadings of the ROPS fitted on the self-propelled sprayer

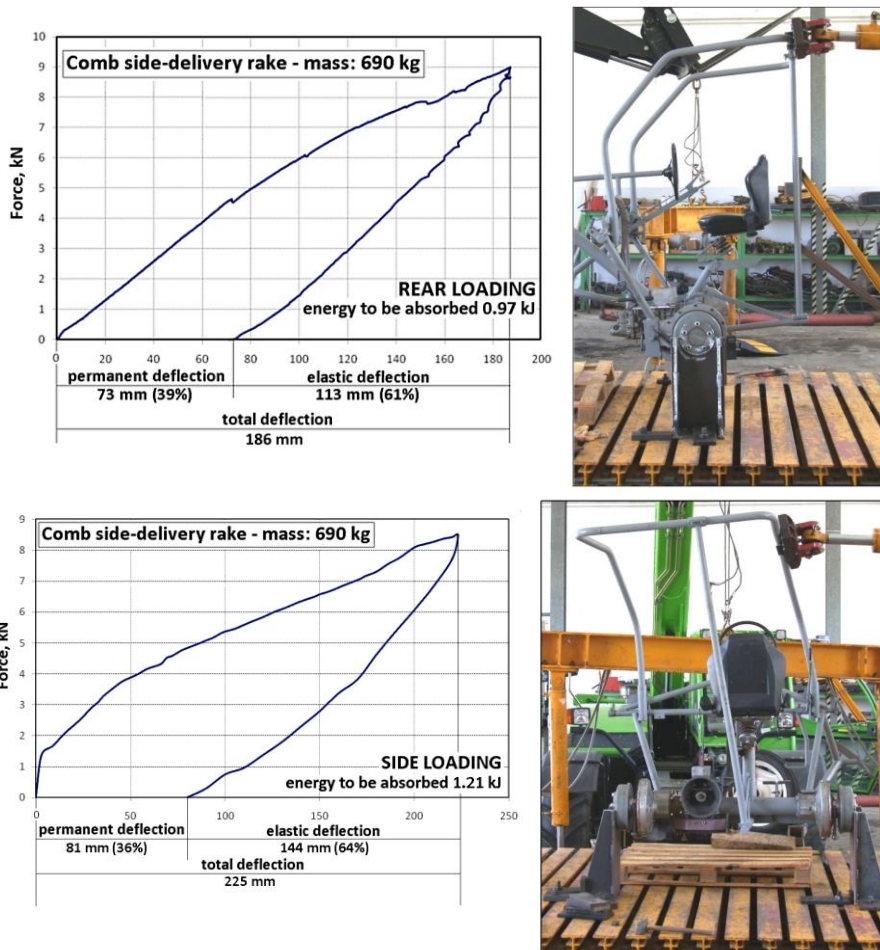

Fig. 6: Force-deflection curves and condition at the end of the rear and side loadings of the ROPS fitted on the comb side-delivery rake

In general, a ROPS is absorbing the energy provided by the formulae both in the strain and stress fields, so resulting a certain amount of both plastic (permanent) and elastic (temporary) deflection.

At the same time, the need to maintain protected the deflection limiting volume (already named “clearance zone”, representing the presumable volume occupied by the driver properly attached to the seat when the machine overturns), as well as to limit at a reasonable overall size the ROPS, often constrains the designer to make a compromise between the possibility to absorb energy in terms of both plastic and elastic deflection. In practice, a well designed ROPS shows a ratio plastic/elastic deflection values ranging between 0.66 and 1.50. In other words, both the plastic and elastic deflection values range normally between 40% and 60% of the total deflection.

As a consequence, a plastic deflection value higher than 60% of the total (and consequently an elastic deflection less than 40%) is typical of a very stiff ROPS, sometime fitted on narrow machines, where the deflection of the pillars has to be quite low, because the structure members must not enter into the clearance zone. On the contrary, on large machines the possibility to fit “elastic” ROPS is higher, due to their largest overall dimensions.

The Plastic (PD) and Elastic (ED) Deflection values recorded for the tests of the ROPS fitted on the self-propelled sprayer (large SPM) confirmed this principle, being respectively 59%-41% (ratio PD/ED = 1.44) for the rear loading, and 46%-54% (ratio PD/ED = 0.85) for the side loading. On the other hand, the ROPS type fitted was a closed cab, made in the majority of its parts with shaped welded steel sheet and tubes.

Different values were on the contrary recorded for the ROPS fitted on the comb side-delivery rake (small SPM), being for the rear and side loadings respectively 39%-61% (ratio PD/ED = 0.64) and 36%-64% (ratio PD/ED = 0.56). In this case, for both loadings the ROPS revealed a poor plasticity, and consequently a very high elasticity. This was because the ROPS was a quite simple frame, manufactured with welded rounded tubes; at the same time, there was no criticism regarding the overall dimensions of the ROPS, having the machine a remarkable wheelbase and track values if compared with its low mass. Moreover, the frame was based on 3 pillars, a very unusual asymmetric design solution, considering that frames and roll-bars fitted normally on agricultural tractors have 2 or 4 pillars.

In **figs. 7 and 8** the final permanent deflection values of the two ROPS are shown, resulting from the entire sequence of the tests. As expected, for both ROPS no high deflection occurred in the vertical plane, having recorded values ranging between 5 mm and 45 mm. This happens because this kind of structures show a remarkable stiffness being the force applied in the direction of their maximum resistance.

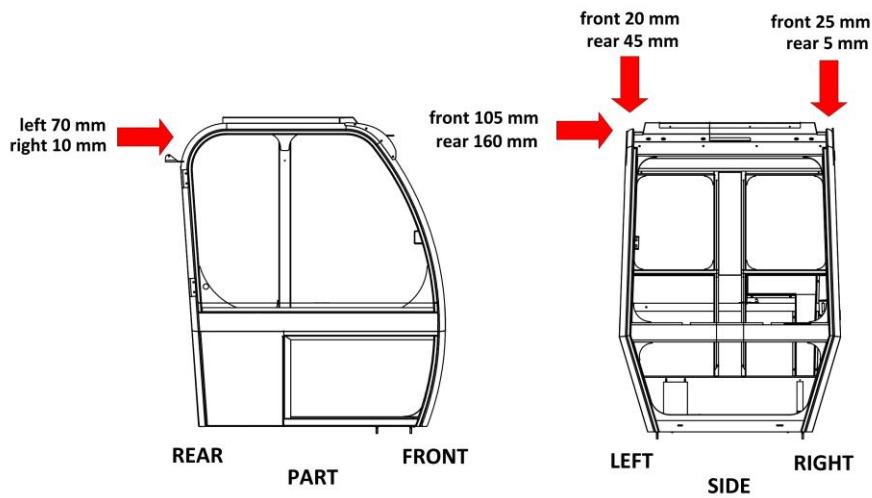

Fig. 7: Permanent deflection values of the ROPS fitted on the self-propelled sprayer, resulting after the entire sequence of the tests provided by OECD Code 4

On the contrary, in the horizontal plane the behavior of the two ROPS was different. In the longitudinal direction (from back forwards), for the cab fitted on the self-propelled sprayer the permanent deflection was logically higher on the side where the loading was applied, while for the comb side-delivery rake the values of the left and right sides were similar, because the frame fitted had just one pillar at its back, more or less in the central position of the structure. Moreover, in this last case the deflection recorded was higher, due to the remarkable elasticity of this ROPS in comparison with the other.

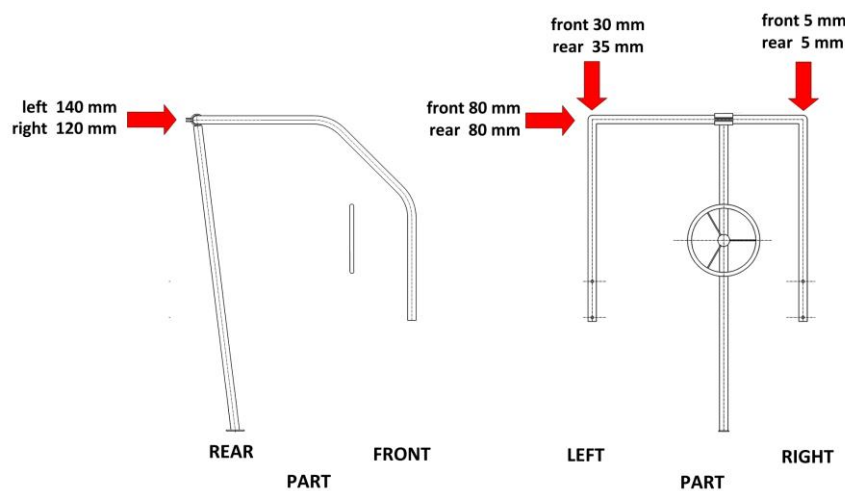

Fig. 8: Permanent deflection values of the ROPS fitted on the comb side-delivery rake, resulting after the sequence of the 4 loadings provided by OECD Code 4

Also the deflection values resulting in the lateral direction were noticeable, due to the high energy to be absorbed in the side loading, which is the most severe in the entire sequence of tests. The cab fitted on the self-propelled sprayer showed a higher deflection in its rear part, while the frame of the comb side-delivery rake highlighted the same deflection in the front and rear parts.

*For both structures, the acceptance conditions of the tests carried out relative to the protection of the clearance zone were fulfilled.* Thus, the two structures can be considered a roll-over protective structure in accordance with the OECD Code 4. On the other hand, the two SPM were not critical for their overall dimensions. The respect of the clearance zone could be difficult on other narrow SPM, such as self-propelled mower or some multifunctional machines used in the livestock breeding, such as for example those to clean the berth edge.

## 4 Conclusions

On the SPM, the protection of the driver in case of overturning (and also that of a possible passenger on board) is still suffering for a lack of dedicated standards. The ISO 16231 is dealing with this question: the approach considered is quite interesting and well promising to solve the problem.

On the other hand, if the fitting of a ROPS is the solution selected by manufacturers to increase the driver's safety in case of overturning, the actual standards developed for agricultural and forestry tractors appear adequate for some categories of large SPM, such as some self-propelled sprayers, but not for several other categories (e.g. combine and grape harvesters), where the driver's place is located in the front part of the machine and sometime on one of the two sides.

The existing Self-Protective Structure (SPS) may modify remarkably the overturning dynamics of the SPM, depending on the stiffness of their points and the definition of the various boundary simulated ground planes. In some cases SPS could represent important means to reduce the mechanical stress of the cab, but in other situations could play a negative role just due to their stiffness, forcing the cab structure to absorb the great part of the energy developed in the tip- or roll-over. This is for example the typical condition in case of front-side overturning when the driver's place is located in the front part of the machine.

The ISO 16231 primarily consider the stability of each SPM, and consequently the level of its risk of overturning. Only if the longitudinal and lateral stability values are lower than the limits established, the manufacturer is compelled to provide other means to reduce the risk. Very often the solution of fitting a ROPS is selected, due to the wide experience acquired on agricultural and forestry tractors. Thus, the accurate and careful definition of the limit stability angles for each SPM category will have a great importance: several studies are in progress, devoted to evaluate the situation on the models currently on the market.

To come to a suitable solution of the general problem, the development of a series of specific standards for the testing of the ROPS designed to be fitted on SPM will

be probably needed, considering that several both large and small SPM differ remarkably from the agricultural and forestry tractors in design and functions.

## References

- [1] I. Arana, J. Mangado, P. Arnal, S. Arazuri, J.R. Alfaro and C. Jarén, Evaluation of risk factors in fatal accidents in agriculture, *Spanish Journal of Agricultural Research*, **8** no. 3, (2010), 592-598.  
<http://dx.doi.org/10.5424/sjar/2010083-1254>
- [2] E. Capacci and V. Rondelli, Evaluation of Testing Procedures for ROPS Fitted on Self-propelled Agricultural Machinery, *Intl Conf Ragusa SHWA 2010 Work Safety and Risk Prevention in Agro-food and Forest Systems* (2010), 202-209.
- [3] C.S. Crandall, L. Fullerton, L. Olson, D.P. Sklar and R. Zumwalt, Farm-related injury mortality in New Mexico, 1980-91, *Accid. Anal. Prev.*, **29** (1997), no. 2, 257-261. [http://dx.doi.org/10.1016/s0001-4575\(96\)00066-8](http://dx.doi.org/10.1016/s0001-4575(96)00066-8)
- [4] L.M. Day, Farm work related fatalities among adults in Victoria, Australia: The human cost of agriculture, *Accid. Anal. Prev.*, **31** (1999), 153-159.  
[http://dx.doi.org/10.1016/s0001-4575\(98\)00057-8](http://dx.doi.org/10.1016/s0001-4575(98)00057-8)
- [5] J. Karlinski, M. Ptak and P. Działak, Simulation tests of roll-over protection structure, *Archives of civil and mechanical engineering*, **13** (2013), no. 1, 57-63. <http://dx.doi.org/10.1016/j.acme.2012.12.001>
- [6] H. Mayrhofer, E. Quendler and J. Boxberger, Prevention aspects for avoiding run-over incidents in agriculture together for tractors, self-propelled harvesting machinery and material handling machinery, *CIGR Journal*, **16** (2014), no. 3, 148-156.
- [7] G. Molari, M. Badodi, A. Guarnieri and M. Mattetti, Structural Strength Evaluation of Driver's Protective Structures for Self-Propelled Agricultural Machines, *J. Agric. Saf. Health*, **20** (2014), no. 3, 165-174.  
<http://dx.doi.org/10.13031/jash.20.10298>
- [8] A.D. Stockton, D.H. O'Neill and C.J. Hampson, Methods for optimising the effectiveness of roll-over protective systems, *HSE-Silsoe Research Institute*, UK (2002), 1-131.
- [9] X. Wang, P. Ayers and A.R. Womac, Static simulation and analyses of mower's ROPS behavior in a finite element model, *Journal Agric. Saf. and Health*, **15** (2009), no. 4, 335-351. <http://dx.doi.org/10.13031/2013.28888>

- [10] INAIL (Istituto Nazionale per l'Assicurazione contro gli Infortuni su Lavoro), Self Protective Structure (SPS) and Roll Over Protective Structure (ROPS) for agricultural self-propelled machines, Rome, Italy, 2013.
- [11] ISO Earth-moving machinery Laboratory tests and performance requirements for protective structures of excavators. Part 2: Roll-over protective structures (ROPS) for excavators of over 6 t, *Norm ISO 12117-2:2008/Cor 1:2010*, Geneva: International Organization for Standardization Publications, 2010.
- [12] ISO Self-propelled agricultural machinery. Assessment of stability, *Norm ISO 16231 - Parts 1 and 2-2013*, Geneva: International Organization for Standardization Publications, 2013.
- [13] OECD document *TAD/CA/T/WD(2012)7*, Report from the Sub-Working Group (SWG) on the extension of ROPS to other Agricultural Machinery. OECD, *Organisation for the Economic Co-operation and Development* Paris, France, 2012.
- [14] OECD Codes 4. OECD Standard Code for the Official Testing of Roll-over Protective Structures on Agricultural and Forestry Tractors, *Organisation for the Economic Co-operation and Development* Paris, France, 2014.

**Received: March 30, 2015; Published: October 16, 2015**