



UNIVERSITÀ DEGLI STUDI DI MILANO

Lombardy Advanced School of Economic Research (LASER)

Department of Economics, Management and Quantitative Methods (DEMM)

**Ph.D. COURSE IN ECONOMICS
XXVII cycle**

“ESSAYS ON MEDIA ECONOMICS”

SECS-P/01 SECS-P/06

Ph.D. CANDIDATE: Serena Marianna DRUFUCA

SUPERVISOR: PROF. Maria Rosa BATTAGGION

COORDINATOR: PROF. Paolo GARELLA

A.Y. 2014-2015

Essays on Media Economics

Serena Marianna Drufuca

Contents

Contents	2
Introduction to Media Economics	5
Bibliography	8
I Media as Two-sided Market	9
1 Quality Competition among Platforms: a Media Market Case ¹	10
1.1 Introduction	10
1.2 Set up	12
1.3 Monopoly	14
1.4 Duopoly	18
1.5 Competition	21
1.6 Entry Deterrence	24
1.7 Conclusions	28
Bibliography	30
Appendix	32
2 Broadcasters Competition on Quality: a Welfare Perspective ²	39
2.1 Introduction	39
2.2 The Multi-Channel Broadcaster	41
2.3 Multi-Channel vs Single-Channel Broadcaster	47
2.4 Competition among Single-Channel Broadcasters	50
2.5 The Welfare Effects of Competition	55
2.6 Conclusions	58
Bibliography	59
Appendix	61

¹This chapter refers to the joint paper Battaglion and Drufuca (2014) "Quality Competition among Platforms: a Media Market Case", Working Papers (2013-) 1402, University of Bergamo, Department of Management, Economics and Quantitative Methods. The authors would like to thank Simon Anderson, Maria Grazia Romano and all participants at the 12th Conference on Media Economics (2014) for helpful comments and discussion.

²This chapter refers to the joint paper Battaglion and Drufuca 2015 "Broadcasters Competition on Quality: a Welfare Perspective", mimeo.

II Political Economy of Mass Media	68
3 Information, Media and Elections: Incentives for Media Capture ³	69
3.1 Introduction	69
3.2 The Model	71
3.3 Equilibrium under Truthful Reporting	73
3.4 Media Capture: Incentives	84
3.5 Conclusions	86
Bibliography	88
Appendix	90
3.6 Proofs of lemmas and propositions	90
Extra Appendix	103
3.7 Conditions on shares	103
3.8 Comparative statics on demand for news	116

³This chapter refers to the paper Drufuca 2014 "Information, Media and Elections: Incentives for Media Capture", Working Papers (2013-) 1402, University of Bergamo, Department of Management, Economics and Quantitative Methods.

Introduction to Media Economics

After the rise of mass media and the increasing consolidation and concentration across the media industries, media economics emerged as an important area of study in order to deal with the economic aspect of mass communication and to understand the activities and functions of media companies as economic institutions. This field of studies has experienced a considerable growth and development over the past 40-50 years, resulting in a huge theoretical and empirical literature.⁴ Media economics embodies theoretical and practical economic questions specific to media of all types. Of particular concern are the economic policies and practices of media companies and disciplines including journalism and the news industry, film production, entertainment programs, print, broadcast, mobile communications, Internet, advertising and public relations.

The economic study of media industries encompasses a variety of methodological approaches, both from a qualitative and quantitative perspective, as well as studies using financial, historical, and political data. The economic analysis of media markets implies the application of economic theories, concepts, and principles to study different aspects (competition, concentration, economic characteristics, market structure, ownership) of mass media companies and industries.

In terms of theoretical analysis, much of the existing work deals with microeconomic theories and studies related to political economy, while just a limited amount of work involves a macroeconomic analysis.⁵ With respect to the *microeconomic* literature, the economic analysis of media markets can be located between the fields of industrial organization and information economics. The *political economy* of the media also encompasses many areas, from sociology to communication to political science. In the first case, media economics considers as important all the dimensions linked to the structure, the functioning and the performance of media firms and industries; in the second, the focus is on the interplay of economy, policy, audience behaviors and preferences.

Media as Two-Sided Markets

Looking at the microeconomic literature of media economics, I consider a particular stream which have recently gained considerable importance. This stream focuses on the key role of media as platforms in the correlation between the audience and advertisers. This approach is known as *two-sided (or multi-sided) market* approach.

Many industries are characterized by the presence of distinct groups of customers who need each other in some way. In these markets there are businesses acting as platforms with the role of providing a common meeting place and facilitating the interactions between members of the customer groups. These platforms play a crucial role by minimizing transactions costs between the different sides of the market. Hence the presence of one or more of these platforms makes possible exchanges that would not occur without them and create values for both sides. In this perspective, all sides of the market may be evaluated as customers by the platforms. A key problem of this kind of markets is to get both (or all) types of customers on board to make the market itself to exist. Indeed, the a wrong pricing

⁴The 1988 was the year of the debut of the Journal of Media Economics (JME).

⁵This branch of literature tends to focus on topics as labor and capital markets, as well as the impact of policies and regulatory actions.

structure could imply the non-existence of the product at all. The importance that the optimal pricing structure has is the main difference with industries based on one-sided markets.

Two-sided markets represent a refinement of the concept of network effects. There are both same-side and cross-side indirect network effects; in principle, each network effect can be either positive or negative, strongly affecting prices and other platforms' strategies. The presence and the effects of indirect network externalities among different sides of the market affect almost all aspects of antitrust analysis - from market definition, to the analysis of cartels, single-firm conduct and efficiencies.⁶

The notion of two-sided (multi-sided) markets first emerged with the pioneering works of Rochet and Tirole (2002) and Caillaud & Jullien (2001; 2003).⁷ While the theory was first developed in relation to payment cards, it was quickly extended to a number of other markets such as newspapers, video games, computer operating systems. Although they seem very different, these markets are all characterized by the fact that the platform must get both sides on board for there to even be a market.

The first part of the present work is devoted to the two-sided approach. In particular, I give special attention to media market case - a unique and well-known species of two-sided market. The idea is that there exists a platform taking on board two opposite side of the market. On one side, the media market in which they sell magazines, newspapers, TV channels and web sites, to a population of readers, viewers and users; on the other, the advertising market in which they sell spaces to advertisers. In this perspective, media platforms generate network externalities in the interaction between advertisers and the audience.

In this particular setup, the equilibrium configuration depends on the role of the advertising: advertisers and platforms seek to expose audience to advertisements, while audience considers advertising as a nuisance. However, it could be argued that advertisements in magazines and newspapers are not as much of a nuisance as they are in TV, radio or web-pages.⁸

There is a burgeoning literature on media platforms.⁹ This literature has dealt with different aspects related to the media market price structure and performance. In this perspective, beside the two-sided mechanism, fundamental questions deal with the effect of competition, the analysis of the pricing structure, quantity, differentiation and quality. In particular, a couple of prominent characteristics have deserved some further attention: the quality and the content variety of the supply. Given that standard IO theory has dealt deeply with the issue of quality (vertical) differentiation and variety (horizontal) differentiation, these classes of models have been extensively used to manage media markets as well, with a peculiar focus on the broadcasting market encompassing both paid and free on air television.

The Political Economy of Media

News media are widely recognized as a vital element for the health of modern democracies. Indeed, the political race to public offices is not limited to electoral competition between candidates but it also includes issues on information acquisition by the electorate. How political information is collected and selected by sources of information and when news are acquired by voters, are essential elements to be considered. In situations of uncertainty about the quality of political candidates, media outlets play an essential role by making available valuable information for electoral decisions. By learning more about candidates, voters are more likely to replace bad types with good ones.

Despite the essential role played by news media in modern democracies, the economic literature has started analysing the market for news only recently. However, this literature has grown rapidly over a

⁶For instance, see Filistrucchi et al. (2013) for discussion and suggestions for the definition of the relevant market in cases involving two-sided platforms.

⁷For a short overview of the literature on two-sided markets see Armstrong (2006), Armstrong and Wright (2007), Gabszewicz and Wauthy (2004), Nocke and Peitz (2007), Hagiu (2006).

⁸This point has been made in Anderson and Gabszewicz (2006).

⁹For a review of the two-sided literature of the media market see Chapters 1 and 2.

large range of research questions. In particular, there is a growing number of contributions discussing the role and the effects of news media on political and public outcomes and inquiring the existence of distortions in the market for news. They have so far analyzed the effects of news media on political selection by looking at whether news media affect the chances of incumbent politicians being re-elected (incumbency advantage) and whether news media have an impact on the type of politicians getting into office (characteristics of elected politicians). Several surveys have been written on this topic: Gentzkow and Shapiro (2008) focus on the issue of the effects of competition on accuracy; DellaVigna and Gentzkow (2010) survey the effects and the drivers of persuasions; Prat and Strömberg (2011) provide an extensive review of the political economy of mass media; Blasco and Sobbrío (2012) deeply discuss the literature on commercial media bias and the influence of advertisers on the accuracy of news media; Sobbrío (2014) provides a survey of the literature and discuss some open research questions.

There are many possible dimensions along which to categorize this literature. Sobbrío (2014) has identified three fundamental questions:

1. Do news media have an effect on political/public policy outcomes?
2. Does media bias exists, why does it exist and what type of bias do we observe?
3. Does media bias matter and, if so, to what extent?

The political literature of media market has tried to assess the effects of the presence of news media and the extent of pluralism on policy outcomes; secondly, it has focused on the specific characteristics of the market for news and on establishing whether or not there is a systematic bias; finally, it has looked at the effects of specific media outlets on political outcomes in order to assess the effects of biased news media.

In this respect I will discuss in Chapter 3 the effects of media sources on audience decision and the possibility for political parties and lobbies to manipulate sources of information to gain electoral consensus.

In the present work, I focus on micro-industrial organization's and political economy's theories used in the study of media economics, referring to two particular streams of the recent literature: media as two-sided market (I.O. field) and the effects of the presence of media bias (political economy field). I provide three different essays on the issue of media markets. In the first part, I deal with the I.O. analysis of media as two-sided markets: the first chapter provides a general framework of vertical differentiated media, analysing the effects of real and potential competition; the second work extended the setting of the first, by comparing different markets structures from a welfare point of view. Finally, in the second part, I move to the political economy approach of media markets, by presenting a theoretical essay on the issue of the interaction between media and politicians during elections.

Bibliography

- [1] Anderson, Simon P. and Gabszewicz, Jean J. (2006) "The Media and Advertising: A Tale of Two-Sided Markets", *Elsevier*, 567-614.
- [2] Armstrong, Mark (2006) "Competition in two-sided markets", *RAND Journal of Economics*, 668-691.
- [3] Armstrong, Mark and Wright, Julian (2007) "Two-sided Markets, Competitive Bottlenecks and Exclusive Contracts", *Economic Theory*, 353-380.
- [4] Blasco, Andrea and Sobbrío, Francesco (2012) "Competition and commercial media bias", *Telecommunications Policy*, 434 - 447.
- [5] Caillaud, Bernard and Jullien, Bruno (2001) "Competing cybermediaries", *European Economic Review*, 797-808.
- [6] Caillaud, Bernard and Jullien, Bruno (2003) "Chicken & Egg: Competition among Intermediation Service Providers", *RAND Journal of Economics*, 309-28.
- [7] DellaVigna, Stefano and Gentzkow, Matthew (2010) "Persuasion: Empirical Evidence", *Annual Review of Economics*, 643-669.
- [8] Filistrucchi, Lapo and Geradin, Damien and van Damme, Eric and Affeldt, Pauline (2013) "Market Definition in Two-Sided Markets: Theory and Practice," Working Papers - Economics wp2013_05.rdf, Università degli Studi di Firenze, Dipartimento di Scienze per l'Economia e l'Impresa.
- [9] Gentzkow, Matthew and Shapiro, Jesse M. (2008) "Competition and Truth in the Market for News", *Journal of Economic Perspectives*, 133-154.
- [10] Gabszewicz, Jean and Wauthy, Xavier (2004) "Two-sided markets and price competition with multi-homing", Université catholique de Louvain, Center for Operations Research and Econometrics (CORE).
- [11] Hagiu, Andrei (2006) "Pricing and commitment by two-sided platforms", *RAND Journal of Economics*, 720-737.
- [12] Nocke, Volker and Peitz, Martin and Stahl, Konrad (2007) "Platform Ownership", *Journal of the European Economic Association*, 1130-1160.
- [13] Prat, Andrea and Strömberg, David (2011) "The Political Economy of Mass Media", C.E.P.R. Discussion Papers.
- [14] Rochet, Jean-Charles and Tirole, Jean (2002) "Cooperation Among Competitors: Some Economics Of Payment Card Associations", *RAND Journal of Economics*.
- [15] Sobbrío, Francesco (2014) "The Political Economy of News Media: Theory, Evidence and Open Issues", in *Handbook of Alternative Theories of Public Economics*, Edward Elgar Publishing, Cheltenham, 278-320.

Part I

Media as Two-sided Market

Chapter 1

Quality Competition among Platforms: a Media Market Case ¹

1.1 Introduction

Quality is a relevant feature of the media market even though it is hard to shape. For instance, when we consider the press, quality is related to accuracy, truth, impartiality and immediacy of information which helps forming public opinions, expressing different/minority voices and performing a watchdog role for public interest. Similarly in broadcasting, content's quality is associated with the purpose of providing not only entertainment, but also education, learning and cultural excellence, without ignoring niche interests (Collins 2007). Furthermore, technological innovations have deeply affected broadcasting quality, for example with higher definition images or interactive services.

Given this multiplicity of meanings, it is also puzzling to figure out the economic framework which better fits media quality. In this respect, there is not a clear distinction between horizontal and vertical differentiation. Indeed, what is conventionally defined as quality is not always attached with a positive value by all individuals. If quality is measured on the extent of informing and educating people (eg. BBC programs), it will be controversial to assume that all individuals consider it as a net benefit.² In this case, it would be more accurate to refer to a taste for variety and to use an horizontal differentiation framework.³ Instead, accuracy and real time of information, the presence of star journalists, the possibility of live performance events (including sports, music and dance), are well-known examples of a vertical quality dimension.

In this respect, the present paper aims to analyze the role of competition in a two-sided market characterized by quality differentiation. In particular we refer to a vertical dimension. We believe that the quality issue should deeply affect the policy debate among free-to-air televisions, pay-tvs and public broadcasters, as well as the debate about newspapers subsidization.

Furthermore, we want to focus on the role of competition in a media market with particular attention to its two-sided market nature. It is a peculiar feature of two-sided markets, that platforms compete on both sides. Platforms, let say broadcasters or newspapers, compete both for audience ⁴ and advertisers in order to maximize profits, namely they should attract consumers' demand as well as advertising spaces. On the one hand, advertising is typically considered as a nuisance for the audience or, in other words, a negative externality; while on the other hand, the audience exerts a positive externality for

¹This chapter refers to the joint paper Battaglion and Druifuca (2014) "Quality Competition among Platforms: a Media Market Case", Working Papers (2013-) 1402, University of Bergamo, Department of Management, Economics and Quantitative Methods. The authors would like to thank Simon Anderson, Maria Grazia Romano and all participants at the 12th Conference on Media Economics (2014) for helpful comments and discussion.

²Consider how many people would prefer a "low-quality" soap-opera to a BBC documentary.

³An alternative interpretation is related to the distinction among news and entertainment, or what has been defined as "hard-news" and "soft-news" (see Hamilton 2004).

⁴With the term "audience" we encompass both viewers (Tv) and readers (Newspapers).

the advertisers. Therefore, competition has a broader meaning with respect to the standard industrial organization literature and it might generate different results with different policy implications.

As a first step, we provide a model to analyze platforms' behavior, in monopoly as well as in duopoly, with vertical differentiation. In a context where platforms endogenously provide their quality levels, we calculate the equilibrium values of advertising, the optimal subscription fees of the viewers/readers and the quality provision in both monopoly and duopoly cases. Then, by considering a duopoly with sequential moves, we investigate how the possibility of entry by a potential competitor not only affects the market share, but also the quality provision of each platform. In this respect we illustrate the feasibility and the profitability of entry deterrence strategy in a two-sided market.

More specifically, due to the single-homing assumption for readers/viewers, while advertisers are multi-homing, platforms have monopoly power in providing access to their single-homing customers to the multi-homing side. In this respect platforms act as "bottlenecks" between advertisers and consumers, by offering sole access to their respective set of consumers. This assumption is crucial to explain the prevailing competition on consumers' side. Furthermore, this is the driving force of the "profit neutrality" result in duopoly.⁵ We also model advertisers as not strategic: their payoffs do not depend on what other advertisers do, but from an advertising benefit, related to market demand. This behavior suits the case of informative advertising.

We think that the effects of endogenous quality provision with different market structures in a two-sided framework deserve a closer attention. In fact, in this set up, we have two forces at stake. Higher quality induces consumers to pay higher subscription fees to join the platform. In turn, the platform can extract surplus on the advertisers side and "invest" them in a reduction of subscription fees, implying that advertisers cross-subsidize single-homing consumers. Therefore, given the profit neutrality, a sort of substitution between quality and advertising comes up. To anticipate the results, we show that the threat of entry may induce a lower differentiation in terms of quality.

1.1.1 Related literature

Media market represents an idiosyncratic example of a two-sided market (see Caillaud and Jullien (2001, 2003), Anderson and Coate (2005), Armstrong (2006), Rochet and Tirole (2006) as seminal references). In particular, our paper belongs to the approach of two-sided markets with vertical differentiation. In this stream of the literature, Armstrong (2005) and Weeds (2013) provide a model with endogenous quality provision in the two-sided context of digital broadcasters. By comparing competition in two different regimes, free-to-air and pay-TV, they show that programme quality is higher in the pay-tv which is also optimal by a social point of view. In a similar setting, Anderson (2007), analyzes the effect of an advertising cap on the quality provision of a monopoly broadcaster and on welfare. He shows that advertising time restriction may improve welfare, but it may also decrease programme quality. More recently, Lin (2011) have extended the analysis to the direct competition among two platforms, where one operate as free-to-air broadcaster, while the second one is a pay-TV broadcaster. In this framework he shows that platforms vertically differentiate their programmes according to the degree of viewers' dislike for advertising. In the same stream, Gonzales-Mestre and Martinez-Sanchez (2013) study, in the free-to-air broadcasting industry, the role of a publicly owned platforms in providing quality, social welfare and optimal level of advertising.

Roger (2010) and Ribeiro et al. (2014) are also close to the present work. They both consider a two-sided structure in the media market, with vertical differentiation as described by Gabszewicz, Wauthy (2012). On one side, in a slightly different context, with respect to the present model, Roger fully characterizes a duopoly equilibrium in pure strategy (and mixed one), with respect to prices, market shares and quality. While Ribeiro et al. (2014) show that a negligible shock on the consumers' side can be disruptive for the market equilibrium when platforms compete on two sides.

⁵For a further discussion on the role of the single-homing or multi-homing assumption see Roger (2010).

Notice that, differently from our model, all the above contributions but Anderson (2007),⁶ focus on the duopoly case, neglecting the monopoly behavior.

For what concerns competition between broadcasters, we refer in particular to Crampes et al. (2009), and Peitz and Valletti (2008). The former paper examines a free-entry model of broadcasting with exogenous programme quality, while we consider competition and entry with endogenous quality provision. The second paper compares advertising intensity and content programming in a market with duopoly broadcasters choosing the degree of horizontal differentiation (i.e. platforms choose the degree of programme “diversity” in the horizontal space, rather than vertical programme quality). In this perspective, our model might be interpreted as a translation to the vertical differentiation context to the Peitz and Valletti (2008) work, with also the extension to the analysis of entry competition.

Finally, our paper is related to an older stream of the literature on industrial organization about vertical differentiation. In particular we are in debt with the well known work of Shaked and Sutton (1982, 1983), which illustrates market equilibrium when firms compete in a vertical differentiated framework and they are ranked according to their quality levels. We extend their conditions to our two-sided framework in order to explain the role of entry and competition.

The paper is organized as follows. Section 1.2 introduces the general model, while Sections 1.3 and 1.4 respectively provide the full characterization of the equilibrium in monopoly and duopoly. Section 5 deals with competition issue. Finally, Section 1.6 investigates the strategy of entry deterrence. Some conclusive remarks (Section 1.7) close the paper.

1.2 Set up

1.2.1 Individuals

There is a continuum of individuals of mass N . They constitute the buyer side in the market. If individuals join a platform they are exposed to contents⁷ and to some informative advertising about market products. All individuals value quality of information in the sense of vertical differentiation: quality of platforms’ content is denoted by the parameter $\theta \in \Theta = [\underline{\theta}, \bar{\theta}]$ with $\bar{\theta} > \underline{\theta} > 0$. Individuals have private valuation β for quality of information, which can be interpreted as their willingness to pay for it. The individual taste for quality β is distributed uniformly on an interval $[\underline{\beta}, \bar{\beta}]$ with $\bar{\beta} > \underline{\beta} > 0$. Moreover, individuals are assumed to dislike advertising. In presence of ads, their utility loss is δa , where a denotes the advertising level and δ the disutility parameter for being exposed to it. Differently from β , the parameter δ is assumed to be invariant across individuals. All individuals can access at most one platform (single-homing).

The utility of an individual from joining platform i of quality θ is:

$$u_i = V - \delta a_i + \beta \theta_i - s_i \quad (1.2.1)$$

where V is the utility of accessing the platform independently of its quality, θ_i denotes platform i ’s quality and a_i the level of advertising. Finally, s_i stands for the subscription fee or the price to access the platform i . Each individual has a reservation utility $u_0 = 0$.

We are able to characterize the individual indifferent between assessing a platform i or not assessing at all :

$$\beta_{0i} = \frac{\delta a_i - V}{\theta_i} + \frac{s_i}{\theta_i} \quad (1.2.2)$$

While the individual indifferent between two platforms is described as follows:

⁶Also Kremhelmer and Zenger (2008) consider a monopoly set up. However, they focus on the problem of adverse selection in the provision of advertising, overlooking the issue of quality.

⁷Media contents are meant in a broad sense, including both information (or hard news) and entertainment (or soft news).

$$\beta_{ik} = \frac{\delta(a_i - a_k)}{(\theta_i - \theta_k)} + \frac{(s_i - s_k)}{(\theta_i - \theta_k)} \quad (1.2.3)$$

for $k \neq i$ and $i > k$.

The expression of β_{0i} and β_{ik} define B_i , namely the share of individuals willing to join the platform i .

1.2.2 Advertisers

The supply side is made by producers who access the platform to advertise their products. They sell products of quality α which are produced at constant marginal costs, set equal to zero. Product quality α is distributed on a interval $[0, \bar{\alpha}]$ according to a distribution function $F(\alpha)$. Individuals have willingness to pay α for a good of quality α . Each producer has monopoly power and can therefore extract the full surplus from individuals by selling their product at price equal to α . As standard in this class of models, we assume advertising to be informative and that just individuals watching the advertisement buy the good. Hence, we refer to producers as advertisers. Advertisers are allowed to multihome and they can advertise in none, one or more platforms. Advertisers have to pay to the platform i an advertising charge r_i . Therefore, advertisers' profits on platform i are:

$$\Pi_a = N\alpha_i B_i - r_i \quad (1.2.4)$$

The advertising charge r_i is endogenously determined by each platform. Due to assumption of single homing on the buyer side, each media platform behaves as a monopoly in carrying its audience to advertiser. Therefore, the advertising charge r_i is set in order to leave the marginal advertiser with zero profit, $\Pi_a = N\alpha_i B_i - r_i = 0$:

$$\alpha_i = \frac{r_i}{NB_i} \quad (1.2.5)$$

Thus, the amount of advertising for each platform is the share of advertisers with $\alpha > \alpha_i$:

$$\alpha_i = 1 - F\left(\frac{r_i}{NB_i}\right) \quad (1.2.6)$$

1.2.3 Platforms

Media markets are characterized by a broad range of *business models*,⁸ both under private or public ownership:⁹ free-to-air Tv under which broadcast platforms are financed just trough advertising revenues, pay-TV under which they are financed through subscription revenues and mixed regime under which they are financed through both subscription fees and advertising. Therefore, to encompass all these cases, we consider a very general framework where platforms are financed both by advertising as well as subscription fees.

Platforms set the advertising space, the subscription prices, which might be positive or negative (subsidies) and their qualities. We assume neither constraints on advertising space (caps)¹⁰ nor costs of running ads. Quality however is costly to provide. We assume that this quality cost is independent of the number of units and is fixed at K (see e.g. Mussa and Rosen (1978) and Hung and Schmitt

⁸In a recent work Calvano and Polo (2014) endogenize the choice of business model by platforms, namely the choice between Free-to-Air and Pay-TV's. In their model they analyse the incentives to a strategic differentiation by business models and they show under which conditions an asymmetric equilibrium exists in which the two firms opt for opposite business models.

⁹In Italy, for instance, we have a public broadcaster financed both by subscription fees (canone RAI) as well as advertising revenues. At the same time we have both free-to-air private operators, such as Mediaset, totally financed through advertising, and private pay-TV's financed through subscription fees and advertising revenues (e.g. Sky).

¹⁰Advertising is trivially just assumed to be positive or null.

(1988)). This assumption fits very well the structure of the ICT and media markets, where there is a prominent role of fixed costs compared to marginal ones (see e.g. Shapiro and Varian (1998), Areeda and Hovenkamp (2014)).¹¹ In other words, once the cost is occurred, the higher quality outlet can be handed out to individuals without any additional charge.¹²

Hence, a media platform collects revenues from both individuals and advertisers. For any platform i the objective function takes the form:

$$\Pi_i(s_i, a_i, r_i, \theta_i) = NB_i s_i + a_i r_i - K \quad (1.2.7)$$

1.2.4 Timing

We assume a three-stage game. In the first stage, platforms choose quality levels of their contents. Then, in the second stage, subscription fees and advertising spaces are set. Finally, in the third stage individuals and advertisers simultaneously decide whether to join a platform or not. Individuals can join at most one platform (single-homing) while advertisers might join more than one (multi-homing). The game is solved backward for a monopoly structure and a duopoly one.

1.3 Monopoly

1.3.1 Monopoly: Individuals' and Advertisers' Demands

By considering the individual indifferent between accessing the monopoly platform or not accessing at all, we obtain the demand function of individuals.

From (1.2.2), by assuming $V = 0$:

$$\beta_{0M} = \frac{\delta a_M}{\theta_M} + \frac{s_M}{\theta_M} \quad (1.3.1)$$

Since individuals are uniformly distributed between $\underline{\beta}$ and $\bar{\beta}$, the demand for the monopoly platform is simply given by the fraction of population with a taste for quality greater than β_{0M} :

$$NB_M = N(\bar{\beta} - \beta_{0M}) = N \left(\frac{\bar{\beta}\theta_M - s_M - \delta a_M}{\theta_M} \right) \quad (1.3.2)$$

Notice that the demand is positive if:

$$\bar{\beta}\theta_M \geq \delta a_M + s_M \quad (1.3.3)$$

From (1.2.6), the share of advertisers willing to join the platform becomes:

$$a_M = 1 - F \left(\frac{r_M}{NB_M} \right) \quad (1.3.4)$$

Having defined the demand function of individuals and advertisers for given prices r_M and s_M , by simultaneously solving equations (1.3.2) and (1.3.4) we get:

$$r_M(s_M, a_M, \theta_M) = F^{-1}(1 - a_M)N \left(\frac{\bar{\beta}\theta_M - s_M - \delta a_M}{\theta_M} \right) \quad (1.3.5)$$

This equation describes how advertising charges react to changes in subscription price, advertising and quality.

¹¹This cost assumption can be justified in the theory of innovation, by the idea that product innovations, endowed with a better quality, depends upon a fixed investment in R&D.

¹²For a further discussion on the role of cost function see Conclusions.

1.3.2 Monopoly: Platform's Subscription Fees and Advertising Level

According to the above assumptions, the monopoly platform maximizes profits subject to a positivity constraint on the advertising level:

$$\begin{cases} \max_{a_H, s_H} \Pi_M = NB_M s_M + a_M r_M - K \\ \text{s.t. } a_M \geq 0 \end{cases} \quad (1.3.6)$$

First order conditions are:

$$\frac{\partial \Pi_M}{\partial a_M} = N \frac{\partial B_M}{\partial a_M} s_M + r_M + a_M \frac{\partial r_M}{\partial a_M} \leq 0 \quad (1.3.7)$$

and

$$\frac{\partial \Pi_M}{\partial s_M} = NB_M + N \frac{\partial B_M}{\partial s_M} s_M + a_M \frac{\partial r_M}{\partial s_M} = 0 \quad (1.3.8)$$

Then, according to the literature, we define the advertising revenues per individual as $\rho(a_i)$

$$\rho(a_i) = \frac{a_i r_i}{NB_i} = \frac{a_i F^{-1}(1 - a_i) NB_i}{NB_i} = a_i F^{-1}(1 - a_i) \quad (1.3.9)$$

We assume $\rho(a_i)$ to be concave in the interval $a \in [0, 1]$. Given that $\rho(a_i) = 0$ for $a_i = 0$ and $a_i = 1$, the function is single-peaked.

Using the definition (1.3.9) for the monopoly platform we can rewrite optimality conditions, proving the following Proposition.

Proposition 1. *The optimal advertising level of the monopoly media platform is:*

$$\rho'(a_M) = \delta \quad (1.3.10)$$

Proof. Given (1.3.9) for the monopoly platform

$$\rho(a_M) = \frac{a_M r_M}{NB_M} = \frac{a_M F^{-1}(1 - a_M) NB_M}{NB_M} = a_M F^{-1}(1 - a_M)$$

we have:

$$r_M = \frac{NB_M \rho(a_M)}{a_M} \quad (1.3.11)$$

Therefore optimality conditions (1.3.7) and (1.3.8) rewrite into (1.3.12) and (1.3.13):

$$Ns_M \frac{\partial B_M}{\partial a_M} + r_M + a_M \left[\frac{(NB_M \rho(a_M) + N \frac{\partial B_M}{\partial a_M} \rho(a_M)) a_M - NB_M \rho(a_M)}{a_M^2} \right] \leq 0 \quad (1.3.12)$$

$$NB_M + Ns_M \frac{\partial B_M}{\partial s_H} + a_M \frac{\partial r_M}{\partial s_M} = 0 \quad (1.3.13)$$

By easy calculation, (1.3.12) and (1.3.13) become respectively:

$$\frac{\partial B_M}{\partial a_M} (s_M + \rho(a_M)) + B_M \rho'(a_M) \leq 0 \quad (1.3.14)$$

$$\frac{\partial B_M}{\partial s_M} (s_M + \rho(a_M)) + B_M = 0 \quad (1.3.15)$$

Given that $\frac{\partial B_M}{\partial a_M} = -\frac{\delta}{\theta_M}$ and $\frac{\partial B_M}{\partial s_M} = -\frac{1}{\theta_M}$, we get:

$$\frac{\partial B_M}{\partial a_M} = \delta \frac{\partial B_M}{\partial s_M}$$

Therefore, plugging in (1.3.14) and (1.3.15), we get the following system:

$$\begin{cases} \delta \frac{\partial B_M}{\partial s_M} (s_M + \rho(a_M)) + B_M \rho'(a_M) \leq 0 \\ \frac{\partial B_M}{\partial s_M} (s_M + \rho(a_M)) + B_M = 0 \end{cases}$$

Finally, if $a_M > 0$ the above inequality is satisfied by equality. Therefore, given that $\rho(a_M)$ is single-peaked, a_M is uniquely determined by the following condition:

$$\rho'(a_M) = \delta$$

with $\delta < \bar{\alpha}$. Otherwise it is zero. \square

The above Proposition 1 states that for a monopoly platform the best reply is to set a fixed advertising space just depending on the disutility of the individuals, as measured by parameter δ . However, the platform does not set the maximum amount of advertising. Notice that our result is in contrast with the suggestion of Peitz and Valletti (2008), where the market is covered and the monopoly advertising space would be maximum at $\rho'(a_M) = 0$.

We can now solve for the equilibrium values, as stated in the following Proposition.

Proposition 2. *With $\rho(a_M)$ concave, we obtain the equilibrium price s_M^* and demand B_M^* as function of quality, revenues per viewer and advertising level.*

Proof. By plugging the expression for B_M in the optimality condition (1.3.15) we obtain:

$$s_M^* = \frac{\bar{\beta}\theta_M - \rho(a_M^*) - \delta a_M^*}{2} \quad (1.3.16)$$

Then,

$$B_M^* = \frac{\bar{\beta}\theta_M + \rho(a_M^*) - \delta a_M^*}{2\theta_M} \quad (1.3.17)$$

\square

The above Proposition 2 shows the result of *profit neutrality*. Revenues from the advertising side are counterbalanced by a decrease in the subscription fee. However, just half of the revenues from advertising is involved in this pass-through effect (see equation (1.3.16)). Moreover, given that subscription fee positively depends on quality, a sort of substitutability between advertising and quality emerges.

1.3.3 Monopoly: Platform's Quality

In order to solve the quality stage, we maximize monopoly profits $\Pi_M(s_M^*, a_M^*, r_M^*, \theta_M)$ with respect to quality θ_M . We obtain the following FOC, subject to $\theta_M \geq 0$:

$$\frac{\partial \Pi_M}{\partial \theta_M} = N \left(\frac{\bar{\beta}^2 \theta_M^2 - (\rho(a_M^*) - \delta a_M^*)^2}{4\theta_M^2} \right) = 0 \quad (1.3.18)$$

By computing the second order condition, we show the convexity of the profit function:

$$\frac{\partial^2 \Pi_M}{\partial \theta_M^2} = \frac{N(\rho(a_M^*) - \delta a_M^*)^2}{2\theta_M^3} > 0 \quad (1.3.19)$$

Unfortunately, in this general framework we cannot determine analytically the equilibrium solution θ_M^* . However, we restrict ourselves on the increasing slope of the profit function (1.3.6). Therefore, we restrict the technological range of quality (Θ) to a narrower set:

$$\Theta_R = [\underline{\theta}, \bar{\theta}] \quad \text{with} \quad \underline{\theta} = \frac{\rho(a_M^*) - \delta a_M^*}{\beta}$$

Therefore, we can prove the following result,

Proposition 3. *In equilibrium, under Θ_R , the monopoly platform chooses the maximum quality.*

Proof. By comparing monopoly profit functions in $\underline{\theta}$ and $\bar{\theta}$, given $\Theta_R = [\underline{\theta}, \bar{\theta}]$ with $\underline{\theta} = \frac{\rho(a_M^*) - \delta a_M^*}{\beta}$, respectively:

$$\Pi_M^*(\underline{\theta}) = \frac{N(\beta \underline{\theta} + \rho(a_M^*) - \delta a_M^*)^2}{4\underline{\theta}} - K$$

$$\Pi_M^*(\bar{\theta}) = \frac{N(\beta \bar{\theta} + \rho(a_M^*) - \delta a_M^*)^2}{4\bar{\theta}} - K$$

we get:

$$\Pi_M^*(\bar{\theta}) - \Pi_M^*(\underline{\theta}) = \frac{1}{4\bar{\theta}} N (\delta a_M^* - \rho(a_M^*) + \beta \bar{\theta})^2 > 0$$

For $\theta \in \Theta_R$ profit are convex and increasing in quality. Therefore to maximize profit the monopoly platform set $\theta_M^* = \bar{\theta}$. \square

Given our result on quality, we obtain equilibrium values for subscription fee and individuals' share:

$$s_M^* = \frac{\beta \bar{\theta} - \rho(a_M^*) - \delta a_M^*}{2} \quad (1.3.20)$$

$$B_M^* = \frac{\beta \bar{\theta} + \rho(a_M^*) - \delta a_M^*}{2\theta_M} \quad (1.3.21)$$

Equilibrium profits are:

$$\Pi_M^*(\bar{\theta}) = \frac{N(\beta \bar{\theta} + \rho(a_M^*) - \delta a_M^*)^2}{4\bar{\theta}} - K \quad (1.3.22)$$

Notice that all equilibrium values depend on $\bar{\beta}$, on the technological constraint, namely the upper bound $\bar{\theta}$, and on the disutility of advertising δ .

We also provide equilibrium results considering a uniform distribution of advertisers, as a special case.

Lemma 1. *In the special case where p.d.f. of advertisers F is uniform on $[0, 1]$, equilibrium values are:*

$$a_M^* = \frac{1 - \delta}{2} \quad (1.3.23)$$

$$s_M^* = \frac{4\bar{\beta}\bar{\theta} - (1 - \delta)(1 + 3\delta)}{8} \quad (1.3.24)$$

and

$$B_M^* = \frac{\beta \bar{\theta} + \left(\frac{1-\delta}{2}\right)^2}{2\bar{\theta}} \quad (1.3.25)$$

1.4 Duopoly

Moving to the duopoly case, we consider two platforms, namely $i = 1, 2$. Without loss of generality we assume that $i = 1$ is the low quality platform, while $i = 2$ is the high quality one. Thus we set $i = L, H$.¹³ For the remaining we maintain the same assumptions as in the general set up (Section 1.2).

In this framework, we consider a market structure where both firms are active (meaning that the individuals' demands for platform H and L are positive) and we look for an equilibrium in the covered market. First, we rule out the trivial case in which the low-quality platform always faces zero demand in the price game. As standard in the vertical differentiation literature (see Tirole 1988), the individuals' heterogeneity has to be sufficiently high:

$$\bar{\beta} > 2\underline{\beta} \quad (1.4.1)$$

Second, for the market to be covered, we introduce the following condition:¹⁴

$$\underline{\beta}\theta_L \geq \frac{(\bar{\beta} - 2\underline{\beta})(\theta_H - \theta_L)}{3} - (\rho(a_L^*) - \delta a_L^*) \quad (1.4.2)$$

which states that in equilibrium also the individual with the lowest taste for quality, gets some positive utility joining the low-quality platform. If we choose Θ such that condition (1.4.2) holds, we obtain *ex-ante* market coverage for every quality belonging to the technological range.¹⁵

Therefore, we define the demand function for the high-quality NB_H and for the low-quality NB_L , respectively:

$$\begin{aligned} NB_H &= N \left(\frac{\bar{\beta} - \beta_{LH}}{\bar{\beta} - \underline{\beta}} \right) \\ &= N \left(\frac{\bar{\beta}}{\bar{\beta} - \underline{\beta}} - \frac{\delta(a_H - a_L)}{(\theta_H - \theta_L)(\bar{\beta} - \underline{\beta})} - \frac{s_H - s_L}{(\theta_H - \theta_L)(\bar{\beta} - \underline{\beta})} \right) \end{aligned} \quad (1.4.3)$$

$$\begin{aligned} NB_L &= N \left(\frac{\beta_{LH} - \underline{\beta}}{\bar{\beta} - \underline{\beta}} \right) \\ &= N \left(\frac{\delta(a_H - a_L)}{(\theta_H - \theta_L)(\bar{\beta} - \underline{\beta})} + \frac{s_H - s_L}{(\theta_H - \theta_L)(\bar{\beta} - \underline{\beta})} - \frac{\underline{\beta}}{\bar{\beta} - \underline{\beta}} \right) \end{aligned} \quad (1.4.4)$$

The amount of advertising for each platform becomes:

$$a_L = 1 - F \left(\frac{r_L}{NB_L} \right) \quad (1.4.5)$$

$$a_H = 1 - F \left(\frac{r_H}{NB_H} \right) \quad (1.4.6)$$

Profit function (1.2.7) rewrites as follow, respectively for the high-quality platform and for the low-one:¹⁶

$$\Pi_H(s_H, s_L, a_H, a_L, r_H, r_L, \theta_H, \theta_L) = NB_H s_H + a_H r_H - K \quad (1.4.7)$$

¹³We relax this ex-ante assumption when we look at the choice of quality (stage 1).

¹⁴This condition is obtained with equilibrium results of stage 3 and 2, as it will be clearer later on. Notice that, compared to the condition ensuring market coverage in a single side framework (see Tirole 1988 p.296) there is an additional part related to the presence of externalities.

¹⁵In a different paper, Battaglion and Drufuca (2014), we provide comparative statics for an appropriate set of parameter values allowing us to deal also with uncovered market.

¹⁶Notice that we assume the cost K to be the same for the low-quality and the high-quality case. In fact, assuming $K_L \neq K_H$ would introduce an ex-ante asymmetry among platforms which just affect the quality stage.

$$\Pi_L(s_H, s_L, a_H, a_L, r_H, r_L, \theta_H, \theta_L) = NB_L s_L + a_L r_L - K \quad (1.4.8)$$

Analogously to the monopoly case, we solve the game backwards. Thus we omit technical details for stage 3 and 2.

Let just point out that we obtain the same result on advertising as in the monopoly solution:

Proposition 4. *For each platform i , if the profit maximizing advertising level is positive, then it is constant and it is determined by*

$$\rho'(a_i) = \delta$$

Proof. See Appendix 1.7. □

The above Proposition 4 states that, for both platforms, a fixed advertising space is the best reply. In particular, the equilibrium level of advertising depends on the advertising disutility of the individuals, suggesting that both platform just compete on individuals. In this respect, platforms act as "bottlenecks" between advertisers and individuals, by offering sole access to their respective set of individuals.

Notice that our result replicates the outcome of Weeds (2013) in a context of vertical differentiation but with quadratic costs.¹⁷ We share the same insight that what really matters for competition, in two-sided markets, is the single-homing part.

Moreover, we point out that:

Remark 1. The strategic advertising choice is the same, regardless the market structure:

$$\rho'(a_i^*) = \delta \quad \text{for } i = H, L, M$$

However, in the duopoly structure, the total amount of advertising doubles the monopoly level. In particular in the uniform case,

$$a_L^* + a_H^* = 1 - \delta = 2a_M^*$$

The above Remark specify that individual platform's strategic advertising choice is neutral with respect to competitive market structure.¹⁸

We can now compare the subscription fees and the advertising prices of the two platforms.

Proposition 5. *Platform H sets a higher subscription fee and a lower advertising price, with respect to platform L : $s_H^*(\theta_H, \theta_L) > s_L^*(\theta_H, \theta_L)$ and $r_H^*(a, \rho) > r_L^*(a, \rho)$. Moreover, they share the market in a fixed proportion: $B_H^* > B_L^*$.*

Proof. See Appendix 1.7. □

Looking at equilibrium subscription fees and market shares, B_H^* and B_L^* , it is straightforward to see a "profit neutrality" result: advertising does not directly affect the market shares and therefore the equilibrium profits, but it just have an impact on the subscription fees.

$$s_H^*(\theta_H, \theta_L, a^*, \delta) = \frac{(2\bar{\beta} - \underline{\beta})(\theta_H - \theta_L)}{3} - \rho(a^*) \quad (1.4.9)$$

$$s_L^*(\theta_H, \theta_L, a^*, \delta) = \frac{(\bar{\beta} - 2\underline{\beta})(\theta_H - \theta_L)}{3} - \rho(a^*) \quad (1.4.10)$$

¹⁷Peitz and Valletti (2008) also find a similar result in a context of horizontal differentiation.

¹⁸This intuition is in line with Ambrus *et al.* (2014). They show that platform ownership does not affect advertising levels, despite non trivial strategic interactions between platforms.

In particular, comparing monopoly with duopoly, it is straightforward to see how the profit neutrality result is stronger under the latter. Indeed, advertising revenues are entirely devoted to reduce subscription fees, while in the monopoly case we just have half displacement (see equation (1.3.16)).

We can now solve the initial stage of the game, namely the quality choice. To anticipate results, we get that profits increase in qualities' distance as standard in vertical differentiation models with single-side. Given our assumption on costs, platforms have the incentive to maximal differentiate.

Proposition 6. *In equilibrium the high quality platform chooses a quality level, $\theta_H^* = \bar{\theta}$ and the low quality platform chooses the minimum quality level, $\theta_L^* = \underline{\theta}$.*

Proof. Rewriting profit function for H and L respectively, (1.4.7) and (1.4.8) we have:

$$\Pi_H^*(\theta_H, \theta_L) = s_H^* NB_H^* + \rho(a_H) NB_H^* - K = N \frac{(\underline{\beta} - 2\bar{\beta})^2 (\theta_H - \theta_L)}{9(\bar{\beta} - \underline{\beta})} - K \quad (1.4.11)$$

$$\Pi_L^*(\theta_H, \theta_L) = s_L^* NB_L^* + \rho(a_L) NB_L^* - K = N \frac{(\bar{\beta} - 2\underline{\beta})^2 (\theta_H - \theta_L)}{9(\bar{\beta} - \underline{\beta})} - K \quad (1.4.12)$$

Computing the FOCs, under the assumption of non-negativity constraint of qualities, we obtain:

$$\begin{aligned} \frac{\partial \Pi_H^*}{\partial \theta_H} &= \frac{(\underline{\beta} - 2\bar{\beta})^2}{9(\bar{\beta} - \underline{\beta})} N > 0 \\ \frac{\partial \Pi_L^*}{\partial \theta_L} &= -\frac{(\bar{\beta} - 2\underline{\beta})^2}{9(\bar{\beta} - \underline{\beta})} N < 0 \end{aligned}$$

Hence:

$$\theta_H^* = \bar{\theta}, \quad \theta_L^* = \underline{\theta}$$

□

To make our results comparable with the monopoly case, we also provide equilibrium results with the uniform distribution of advertisers.

Lemma 2. *In the special case where the p.d.f. of advertisers $F(\cdot)$ is uniform on $[0, 1]$ equilibrium values are:*

$$a_L^* = a_H^* = a^* = \frac{1 - \delta}{2} \quad (1.4.13)$$

$$s_H^*(\theta_H, \theta_L, \delta) = \frac{(2\bar{\beta} - \underline{\beta})(\bar{\theta} - \underline{\theta})}{3} - \frac{1 - \delta}{2} \left(\frac{1 + \delta}{2} \right) \quad (1.4.14)$$

$$s_L^*(\theta_H, \theta_L, \delta) = \frac{(\bar{\beta} - 2\underline{\beta})(\bar{\theta} - \underline{\theta})}{3} - \frac{1 - \delta}{2} \left(\frac{1 + \delta}{2} \right) \quad (1.4.15)$$

Notice that, the advertising level is decreasing in the disutility parameter δ . Instead, both subscription fees s_L^* and s_H^* are increasing in δ . This result is in line with our findings about profit neutrality: a higher δ implies lower advertising revenues to be used in the reduction of fees. As expected, profits are neutral in δ , differently from the monopoly case (see equation (1.3.22))

Finally, equilibrium market shares and qualities are not affected by the assumption on $F(\cdot)$.

1.5 Competition

In this Section we take into account the effects of competition on market structure and on platforms' qualities. We have already considered both monopoly and duopoly situation and their comparison. However, the above framework does not allow to deal with the potential competition and the issue of incumbency advantage. Therefore we analyze quality differentiation in a framework of sequential entry. We slightly modify our timing by considering an Incumbent platform and an Entrant platform. We split the quality choice stage: the Incumbent platform (I) sets quality first, followed by the Entrant platform (E). Technology structure and profit function are the same, but for the entry cost F , as it is standard in this literature. In this framework we focus on the existence conditions of a duopoly equilibrium and we check robustness by looking at the entry deterrence strategy by the Incumbent.

1.5.1 Sequential Duopoly

As already mentioned, in order to deal with a sequential equilibrium, we slightly modify the timing of the game. Nothing change for stages 3 and 2, while we separate the quality decision of the two platforms: the Incumbent platform sets quality first, followed by the Entrant platform. After quality-choice the two platforms set simultaneously their prices for advertising and subscription fees, r_i and s_i , as in the previous setting. Hence, the equilibrium solutions for stages 3 and 2 still hold (see Proposition 5). Recall that equilibrium profits of the high-quality platform were higher with respect to the low-quality one. Therefore the Incumbent platform will exploit its advantage, behaving as the high quality one and just living room to entry at the low quality level. Equilibrium solutions of the simultaneous framework, with $E = L$ for the Entrant and $I = H$ for the Incumbent are as follows.

Equilibrium subscription fees:

$$\begin{aligned} s_I^* &= \frac{(2\bar{\beta} - \underline{\beta})(\theta_I - \theta_E)}{3} - \rho(a^*) \\ s_E^* &= \frac{(\bar{\beta} - 2\underline{\beta})(\theta_I - \theta_E)}{3} - \rho(a^*) \end{aligned} \quad (1.5.1)$$

Equilibrium demands:

$$\begin{aligned} NB_I^* &= N \frac{2\bar{\beta} - \underline{\beta}}{3(\bar{\beta} - \underline{\beta})} \\ NB_E^* &= N \frac{\bar{\beta} - 2\underline{\beta}}{3(\bar{\beta} - \underline{\beta})} \end{aligned} \quad (1.5.2)$$

Equilibrium advertising prices:

$$\begin{aligned} r_I^* &= N \frac{\rho(a^*)}{a^*} \frac{2\bar{\beta} - \underline{\beta}}{3(\bar{\beta} - \underline{\beta})(\theta_I - \theta_E)} \\ r_E^* &= N \frac{\rho(a^*)}{a^*} \frac{\bar{\beta} - 2\underline{\beta}}{3(\bar{\beta} - \underline{\beta})(\theta_I - \theta_E)} \end{aligned} \quad (1.5.3)$$

Equilibrium profits

$$\begin{aligned} \Pi_I^* &= N \frac{(2\bar{\beta} - \underline{\beta})^2}{9(\bar{\beta} - \underline{\beta})} (\theta_I - \theta_E) - K \\ \Pi_E^* &= N \frac{(\bar{\beta} - 2\underline{\beta})^2}{9(\bar{\beta} - \underline{\beta})} (\theta_I - \theta_E) - K - F \end{aligned} \quad (1.5.4)$$

Indeed, the Entrant platform fixes its quality in order to maximize profits given the quality choice of the Incumbent .

$$\Pi_E^* = N \frac{(\bar{\beta} - 2\underline{\beta})^2}{9(\bar{\beta} - \underline{\beta})} (\theta_I - \theta_E) - K - F$$

$$\frac{\partial \Pi_E^*}{\partial \theta_E} |_{\theta_I} = -N \frac{(\bar{\beta} - 2\underline{\beta})^2}{9(\bar{\beta} - \underline{\beta})} < 0$$

Given the negative sign of the derivative, platform E has the incentive to choose the minimum quality $\underline{\theta}$.

The final stage involves the quality choice of the Incumbent platform:

$$\begin{aligned} \Pi_I^* &= N \frac{(2\bar{\beta} - \underline{\beta})^2}{9(\bar{\beta} - \underline{\beta})} (\theta_I - \theta_E^*) - K \\ &= N \frac{(2\bar{\beta} - \underline{\beta})^2}{9(\bar{\beta} - \underline{\beta})} (\theta_I - \underline{\theta}) - K \\ \frac{\partial \Pi_I^*}{\partial \theta_I} &= N \frac{(2\bar{\beta} - \underline{\beta})^2}{9(\bar{\beta} - \underline{\beta})} > 0 \end{aligned}$$

Given the positive sign of the derivative, platform I has the incentive to choose the maximum quality. In equilibrium, profits of the sequential duopoly are:

$$\Pi_I^* = N \frac{(2\bar{\beta} - \underline{\beta})^2}{9(\bar{\beta} - \underline{\beta})} (\bar{\theta} - \underline{\theta}) - K \quad (1.5.5)$$

$$\Pi_E^* = N \frac{(\bar{\beta} - 2\underline{\beta})^2}{9(\bar{\beta} - \underline{\beta})} (\bar{\theta} - \underline{\theta}) - K - F \quad (1.5.6)$$

As in the simultaneous case, we obtain a result of maximal differentiation. Revenues are not changed for both platforms, however I has the incumbency advantage to be first on the market, behaving as the high quality platform and saving entry costs.

1.5.2 Threat of Entry

In this Section we analyze the effect of potential competition, by means of potential entrance of new competitors. As above mentioned, the Incumbent platform would behave as the high quality one, just living room to entry at the low quality level. Given this framework, we point out the impact of potential competition on platforms' qualities and on their differentiation.

On the one hand, notice that with fixed cost of entry a potential entrant cannot profitably leapfrog the high-quality incumbent. In fact, the quality is already at maximum, therefore the only possibility is to charge lower prices with the same quality. However, the cost of entry prevent this strategy to be profitable. On the other hand, the existence of positive profits for the low quality platform make convenient for a potential entrant to get in the market. In this case, by setting a slightly larger quality the entrant will capture all the low-quality demand. According to Shaked and Sutton (1982) in a traditional model of vertical differentiation, there are at most two firms having positive market

share and covering the entire market with different qualities, for a convenient heterogeneity of the individuals.¹⁹ We show that this condition applies to the two-sided market context too.²⁰

Lemma 3. *Let $2\underline{\beta} < \bar{\beta} < 4\underline{\beta}$. Then of any n platforms offering distinct qualities, exactly two will have positive market shares on the buyers' side (audience) at equilibrium. Moreover at equilibrium the market is covered.*

Proof. See Appendix 1.7. □

Therefore by assuming $2\underline{\beta} < \bar{\beta} < 4\underline{\beta}$ we know that in equilibrium the market is covered by the two highest platforms' qualities. Hence, we can state that a survival strategy for the low quality platform would be to drive profit to zero. In this way no other platform has the incentive to get in. Given that, we have to check how quality levels of the Incumbent (high quality) and the Entrant (low quality) might be affected.

Proposition. *Under the threat of entry the equilibrium quality of the Incumbent platform θ_I^* lies in the interval $[\max(\tilde{\theta}_I, \tilde{\theta}_I), \bar{\theta}]$ while the product quality choice of firm E is such that $\theta_E^* = \theta_I^* - (K + F) \frac{9(\bar{\beta} - \underline{\beta})}{N(\bar{\beta} - 2\underline{\beta})^2}$.*

Proof. Let start with platform E . Platform E should drive its profit to zero, in order to prevent the entrance of a new platform:

$$\Pi_E^* = N \frac{(\bar{\beta} - 2\underline{\beta})^2}{9(\bar{\beta} - \underline{\beta})} (\theta_I - \theta_E) - K - F = 0 \quad (1.5.7)$$

then

$$\theta_E^* = \theta_I - (K + F) \frac{9(\bar{\beta} - \underline{\beta})}{N(\bar{\beta} - 2\underline{\beta})^2} \quad (1.5.8)$$

Given the choice of platform E the profit of the Incumbent becomes:

$$\Pi_I^*(\theta_E^*) = \frac{\Pi_E^*(\theta_E^*)}{3\bar{\beta}^2 - 3\underline{\beta}^2} K + \frac{(2\bar{\beta} - \underline{\beta})^2}{(\bar{\beta} - 2\underline{\beta})^2} F$$

Incumbent profits are constant (independent of quality) and positive. However, we should assess a range of quality for the platform I compatible with the duopoly equilibrium, such that a second platform can just survive as a low quality. We calculate two threshold values for the Incumbent, $\tilde{\theta}_I$ and $\tilde{\theta}_I$, such that the profits of the Entrant are driven to zero if it enters with the lowest quality $\underline{\theta}$ or with the highest quality $\bar{\theta}$ respectively:

$$\begin{aligned} \Pi_E^*(\tilde{\theta}_I, \underline{\theta}) &= 0 \\ \tilde{\theta}_I &= \underline{\theta} + (F + K) \frac{9(\bar{\beta} - \underline{\beta})}{N(\bar{\beta} - 2\underline{\beta})^2} \end{aligned} \quad (1.5.9)$$

¹⁹That is: $2a < b < 4a$, where a and b are the lower and the upper bounds of the distribution respectively (Shaked, Sutton (1982), p.5).

²⁰We focus on the buyers' side which is the crucial one. In fact, according to the assumption of multi-homing advertisers the competition on this side does not affect the equilibrium values. Furthermore the optimality condition on advertising is irrespective of the number of platforms (see Remark 1).

and

$$\begin{aligned} \Pi_E^*(\tilde{\theta}_I, \bar{\theta}) &= 0 \\ \tilde{\theta}_I &= \bar{\theta} - (K - F) \frac{9(\bar{\beta} - \underline{\beta})}{N(2\bar{\beta} - \underline{\beta})^2} \end{aligned} \quad (1.5.10)$$

Indeed, if $\theta_I > \tilde{\theta}_I$ then it is possible for platform E to enter at the low level with quality θ_E^* . If, also, $\theta_I > \tilde{\theta}_I$ then platform E cannot leapfrog the high quality. Hence under the threat of entry a duopoly equilibrium exists for $\theta_I^* \in \max(\tilde{\theta}_I, \tilde{\theta}_I), \bar{\theta}]$ and $\theta_E^* = \theta_I^* - (K + F) \frac{9(\bar{\beta} - \underline{\beta})}{N(2\bar{\beta} - \underline{\beta})^2}$. \square

Remark 2. In equilibrium, under the threat of entry the quality differentiation may decrease: $(\theta_I^* - \theta_E^*) \leq (\bar{\theta} - \underline{\theta})$.

This statement follows Proposition 1.5.2, by noting first that the Incumbent platform does not necessary reach the maximum quality. While the Entrant platform sets a quality above the minimum unless the entry cost F and K are sufficiently high. Notice that if we assume $K = 0$ and we consider the minimum $\underline{\theta} = \frac{\rho(a^*) - \delta a^*}{\beta}$ as in the monopoly case, then if $(\theta_I^* - \theta_E^*) < (\bar{\theta} - \underline{\theta})$ certainly holds if $\bar{\theta} > F \frac{9(\bar{\beta} - \underline{\beta})}{N(2\bar{\beta} - \underline{\beta})^2} + \frac{\rho(a^*) - \delta a^*}{\beta}$.

The threat of entry shakes the equilibrium configuration. The quality of platform I might decrease, while the quality of platform E might increase. Therefore quality differentiation may shrink. In this respect there is no evidence that increasing competition positively affect the high quality of the Incumbent. Conversely, potential competition, namely the threat of entry, can boost the quality of the Entrant from a minimum level.²¹

1.6 Entry Deterrence

To check the robustness of the previous equilibria, we wonder if investment in quality might be a successful deterrence strategy. More precisely, we state under which conditions an incumbent prevents entry in the market. In this way we endogenize the monopoly structure in a two-sided framework with a quality choice. The difference in equilibrium qualities between the accommodation case (duopoly) and the deterrence case (threatened monopoly), measures the effects of the potential competition.

This analysis is performed introducing a new stage of the game, where the Entrant platform has to take the decision to enter the market or to stay out, while the Incumbent platform is already in. In order to distinguish from the previous case, we slightly modify the notation such that the Incumbent is defined as platform 1 and the Entrant as platform 2.

In this framework we check whether or not deterrence is a feasible strategy. We compute profits of platform 1 in case of deterrence. If platform 1 decides to preempt the entry of the potential entrant, it behaves as a threaten monopolist. In this case, all the assumptions of the monopoly - uniform distribution of advertisers between (0,1) and $\underline{\theta} = \frac{(1 - \delta)^2}{4\bar{\beta}}$ - hold. Having defined threshold values $\tilde{\theta}_1$ and $\tilde{\tilde{\theta}}_1$ (see equations (1.5.9) and (1.5.10)), as in Proposition 1.5.2, we prove the following statement.

Proposition 7. *Given $\tilde{\theta}_1$ and $\tilde{\tilde{\theta}}_1$, if:*

- $\tilde{\theta}_1 < \tilde{\tilde{\theta}}_1$ monopoly platform cannot prevent entry for $\theta \in (\underline{\theta}, \bar{\theta})$, therefore deterrence is an unfeasible strategy (a)

²¹Notice that our insights are in the same line with results of Hung and Schmitt (1988) in a traditional one-side market.

- $\tilde{\theta}_1 > \tilde{\tilde{\theta}}_1$ monopoly platform can prevent entry for $\theta_1^D = \tilde{\theta}_1 - \varepsilon$, with ε enough close to zero, therefore deterrence is a feasible strategy (b)

Proof. (a) According to Proposition 1.5.2, to prevent the entry of a high quality platform, the incumbent should set $\theta_1 > \tilde{\tilde{\theta}}_1$, while it prevents entry on low quality level if $\theta_1 < \tilde{\theta}_1$. Therefore it is straightforward to see that if $\tilde{\theta}_1 < \tilde{\tilde{\theta}}_1$ it does not exist any θ_1 such that entry is prevented at both high quality and low quality levels.

(b) According to Proposition 1.5.2, we know that for $\tilde{\theta}_1 > \tilde{\tilde{\theta}}_1$ it exist a value of θ_1 such that the incumbent can prevent the entry on both high quality and low quality sides. In particular for $\forall \theta \in (\tilde{\theta}_1, \tilde{\tilde{\theta}}_1)$ entry can be deterred. Recalling that for a quality $\theta \geq \underline{\theta} = \frac{(1-\delta)^2}{4\bar{\beta}}$ the monopoly profits are increasing in quality. Hence, the incumbent optimal deterrence strategy is to set $\theta_1^D = \tilde{\theta}_1 - \varepsilon$ close enough to $\tilde{\theta}_1$. \square

The above proposition states under which conditions platform 1 is able to deter entry. In case (a) the only equilibrium strategy is accommodation, while in case (b), entry deterrence is feasible but it is not necessarily an equilibrium. To be an equilibrium, monopoly profit in the deterrence quality θ_1^D must be higher than duopoly's one (accommodation). Otherwise, platform 1 should accommodate even if $\tilde{\theta}_1 > \tilde{\tilde{\theta}}_1$.

According to Proposition 7, if $\tilde{\theta}_1 > \tilde{\tilde{\theta}}_1$ platform 1 can prevent entry for $\theta_1^D = \tilde{\theta}_1 - \varepsilon$, with ε enough close to zero. Now, we should check when the entry deterrence strategy is profitable with respect to the accommodation strategy. We calculate deterrence profit in θ_1^D :

$$\Pi_M(\theta_1^D) = \frac{N \left(\bar{\beta} \theta_1^D + \left(\frac{1-\delta}{2} \right)^2 \right)^2}{4\theta_1^D} - K \quad (1.6.1)$$

Considering $\theta_1^D = \tilde{\theta}_1 - \varepsilon$ and taking the limit of (1.6.1), we obtain:

$$\lim_{\varepsilon \rightarrow 0} \Pi_M(\theta_1^D) = \frac{N \left(\bar{\beta} \left(\frac{(1-\delta)^2}{4\bar{\beta}} + (F+K) \frac{9(\bar{\beta}-\underline{\beta})}{N(\bar{\beta}-2\underline{\beta})^2} \right) + \left(\frac{1-\delta}{2} \right)^2 \right)^2}{4 \left(\frac{(1-\delta)^2}{4\bar{\beta}} + (F+K) \frac{9(\bar{\beta}-\underline{\beta})}{N(\bar{\beta}-2\underline{\beta})^2} \right)} - K \quad (1.6.2)$$

We compare (1.6.2) with the duopoly profits (accommodation case) as previously calculated in Proposition 1.5.2:

$$\Pi_1 = \frac{3\bar{\beta}^2 - 3\underline{\beta}^2}{(\bar{\beta} - 2\underline{\beta})^2} K + \frac{(2\bar{\beta} - \underline{\beta})^2}{(\bar{\beta} - 2\underline{\beta})^2} F \quad (1.6.3)$$

Under the assumptions $K = 0$, $N = 1$ and $2\underline{\beta} < \bar{\beta} < 4\underline{\beta}$ we compare (1.6.1) and (1.6.3). There exists a threshold value of the fixed cost of entry $\underline{F}(\delta, \bar{\beta}, \underline{\beta})$ which makes the accommodation and deterrence profits equal. According to these values, we define the condition under which deterrence is profitable with respect to accommodation. Indeed, for $F < \underline{F}(\delta, \bar{\beta}, \underline{\beta})$ accommodation profits are lower then the deterrence ones, making preemption a profitable strategy.

1.6.1 Entry Deterrence: a Numerical Simulation

Unfortunately we are not able to find an analytical solution for $\underline{F}(\delta, \bar{\beta}, \underline{\beta})$ and, in turn, the conditions such that $F < \underline{F}(\delta, \bar{\beta}, \underline{\beta})$ holds. However, we can perform a numerical simulation to ascertain the existence of a set of parameter values such that entry deterrence strategy is profitable with respect to the accommodation.

Given that \underline{F} depends upon $\delta, \bar{\beta}, \underline{\beta}$ we start by restricting the set of values of $\bar{\beta}, \underline{\beta}$ according to Lemma 3. Doing that we set the value of $\bar{\beta}$ as a function of different values of $\underline{\beta}$. Then, we compute deterrence profits, (1.6.2), and accommodation ones, (1.6.3), for every combination of $\underline{\beta}$ and $\bar{\beta}(\underline{\beta})$.²² This simulation has been repeated for three different values of $\delta \in (0, 1)$, namely 0.01, 0.5 and 0.9. The numerical simulation does not make any remarkable difference according to the δ change, therefore we just show the results for $\delta = 0.5$.

Table 1.6.1: Monopoly ($\Pi_M(\theta_1^D)$) and Duopoly (Π_1) Profits for $\delta = 0.5$

$\underline{\beta}$	$\bar{\beta} = 2.00001\underline{\beta}$	$\bar{\beta} = 3\underline{\beta}$	$\bar{\beta} = 4\underline{\beta}$
0.00001	$\Pi_M(\theta_1^D) = \frac{(1.8 \times 10^{11} F + 0.125)^2}{3.6 \times 10^{16} F + 12500}$ $\Pi_1 = 9.0001 \times 10^{10} F$	$\Pi_M(\theta_1^D) = \frac{(54F + 0.125)^2}{7.2 \times 10^6 F + 8333.3}$ $\Pi_1 = 25F$	$\Pi_M(\theta_1^D) = \frac{(27F + 0.125)^2}{2.7 \times 10^6 F + 6250}$ $\Pi_1 = 12.25F$
0.5	$\Pi_M(\theta_1^D) = \frac{(1.8 \times 10^{11} F + 0.125)^2}{7.2001 \times 10^{11} F + 0.25}$ $\Pi_1 = 9.0001 \times 10^{10} F$	$\Pi_M(\theta_1^D) = \frac{(54F + 0.125)^2}{144F + 0.16667}$ $\Pi_1 = 25F$	$\Pi_M(\theta_1^D) = \frac{(27.0F + 0.125)^2}{54.0F + 0.125}$ $\Pi_1 = 12.25F$
1	$\Pi_M(\theta_1^D) = \frac{(1.8 \times 10^{11} F + 0.125)^2}{3.6 \times 10^{11} F + 0.125}$ $\Pi_1 = 9.0001 \times 10^{10} F$	$\Pi_M(\theta_1^D) = \frac{(54F + 0.125)^2}{72F + 8.3333 \times 10^{-2}}$ $\Pi_1 = 25.0F$	$\Pi_M(\theta_1^D) = \frac{(27F + 0.125)^2}{27F + 0.0625}$ $\Pi_1 = 12.25F$
5	$\Pi_M(\theta_1^D) = \frac{(1.8 \times 10^{11} F + 0.125)^2}{7.2001 \times 10^{10} F + 2.5 \times 10^{-2}}$ $\Pi_1 = 9.0001 \times 10^{10} F$	$\Pi_M(\theta_1^D) = \frac{(54F + 0.125)^2}{\frac{72}{5} F + 1.6667 \times 10^{-2}}$ $\Pi_1 = 25.0F$	$\Pi_M(\theta_1^D) = \frac{(27F + 0.125)^2}{\frac{27}{5} F + 0.0125}$ $\Pi_1 = 12.25F$
12	$\Pi_M(\theta_1^D) = \frac{(1.8 \times 10^{11} F + 0.125)^2}{3.0 \times 10^{10} F + 1.0417 \times 10^{-2}}$ $\Pi_1 = 9.0001 \times 10^{10} F$	$\Pi_M(\theta_1^D) = \frac{(54F + 0.125)^2}{6F + 6.9444 \times 10^{-3}}$ $\Pi_1 = 25.0F$	$\Pi_M(\theta_1^D) = \frac{(27F + 0.125)^2}{\frac{9}{4} F + 5.2083 \times 10^{-3}}$ $\Pi_1 = 12.25F$

A closer look at the deterrence and accommodation profits (see Table 1.6.1) helps to grab more insights. The key point is that Π_1 decreases in the taste for quality $\bar{\beta}(\underline{\beta})$, which appears to be a quite counterintuitive finding. This is the result of a pass-through effect of a change in the profit of the entrant platform. Indeed, as already described in Proposition 1.5.2, in case of potential entry, the platform 2 has to drive profit to zero in order to not induce the entry of further competitors. Given that the entrant platform's profit would have been increasing in $\bar{\beta}$ (see equation 1.5.7), the quality of the platform 2 must to increase in order to reduce differentiation and meet again the zero-profit condition, as stated in equation (1.5.8). Hence, due to a lower differentiation, Π_1 decreases. Therefore, accommodation profits for the incumbent platform are decreasing in $\bar{\beta}$. In the case of a decrease in $\underline{\beta}(\underline{\beta})$ analogous results hold (see Tables 1.7.1 and 1.7.2 in Appendix 1.7). For what concerns the deterrence case, Table 1.6.1 shows a similar path in $\Pi_M(\theta_1^D)$. Hence, monopoly profits are decreasing in $\bar{\beta}(\underline{\beta})$. To better figure out this result, we focus on the relationship between quality and $\bar{\beta}$ in the entry deterrence case. From Proposition (7) we have $\theta_1^D = \tilde{\theta}_1 - \varepsilon$. By taking the limit of θ_1^D for ε close to zero, we get:

$$\theta_1^D = \underline{\theta} + (F + K) \frac{9(\bar{\beta} - \underline{\beta})}{N(\bar{\beta} - 2\underline{\beta})^2} = \frac{(1 - \delta)^2}{4\bar{\beta}} + (F + K) \frac{9(\bar{\beta} - \underline{\beta})}{N(\bar{\beta} - 2\underline{\beta})^2} \quad (1.6.4)$$

By simple calculation from equation (1.6.4) we have:

²²We also checked the values of $\underline{\beta}$ as a function of different values of $\bar{\beta}$, (see Tables 1.7.1 and 1.7.2 in Appendix 1.7), without any relevant difference in the results. Thus, for the sake of exposition we focus on the $\bar{\beta}(\underline{\beta})$ case.

$$\frac{\partial \theta_1^D}{\partial \bar{\beta}} < 0$$

Given that monopoly profits are increasing in quality, it is straightforward to see that deterrence profits $\Pi_M(\theta_1^D)$ are decreasing in $\bar{\beta}$. The intuition is similar to the accommodation case. Given that the entrant's profits are increasing in $\bar{\beta}$, the incumbent platform need a lower quality to prevent entry. Therefore for the platform 1 the cost of deterrence is increasing in $\bar{\beta}$. The same happens in case of a decrease of $\underline{\beta}(\bar{\beta})$ (see Table 1.7.1).

According to profit functions, we are able to calculate the value of $\underline{F}(\delta, \bar{\beta}, \underline{\beta})$. As we said, we just report the result for $\delta = 0.5$ in Table 1.6.2.

Table 1.6.2: Values of $\underline{F}(\delta, \bar{\beta}(\underline{\beta}))$ for $\delta = 0.5$

$\underline{\beta}$	$\bar{\beta} = 2.00001\underline{\beta}$	$\bar{\beta} = 3\underline{\beta}$	$\bar{\beta} = 4\underline{\beta}$
0.00001	$\underline{F} = 1.3889 \times 10^{-17}$	$\underline{F} = 7.5 \times 10^{-8}$	$\underline{F} = 2.0408 \times 10^{-7}$
0.5	$\underline{F} = 1.1236 \times 10^{-12}$	$\underline{F} = 1.5153 \times 10^{-2}$	$\forall F > 0$
1	$\underline{F} = 9.375 \times 10^{-8}$	$\forall F > 0$	$\forall F > 0$
5	$\forall F > 0$	$\forall F > 0$	$\forall F > 0$
12	$\forall F > 0$	$\forall F > 0$	$\forall F > 0$

First, notice that for sufficiently high levels of $\bar{\beta}$ deterrence profits are always larger than the accommodation ones for every values of F . Therefore in these cases, without calculating the threshold value \underline{F} , we can state that deterrence strategy dominates accommodation. Second, for the remaining cases, the above Table 1.6.2 shows the values of \underline{F} such that deterrence and accommodation profits equal. Therefore, for $0 < F < \underline{F}$ deterrence is admissible and profitable, as shown in the graphical example below (Figure 1.6.1). Otherwise accommodation strategy is preferable.

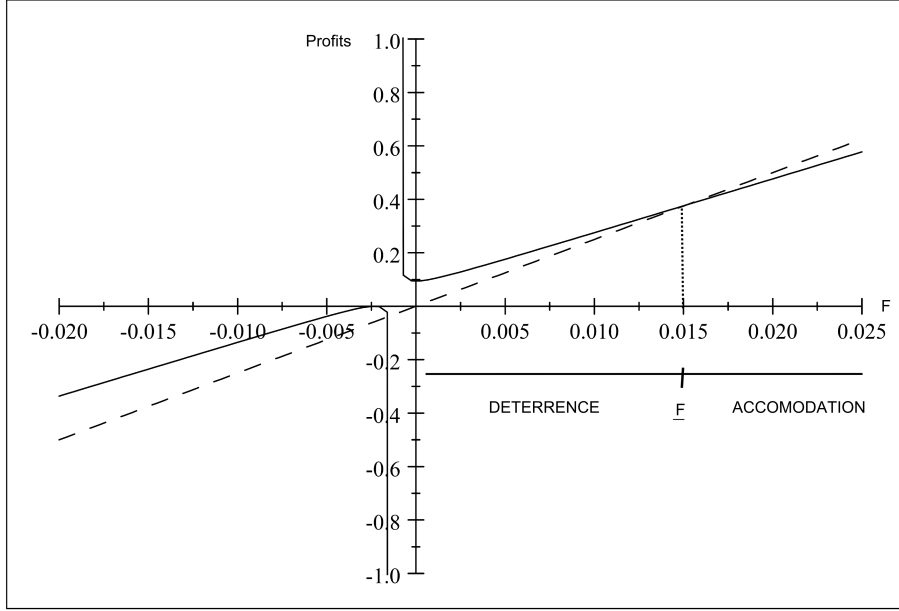

Figure 1.6.1: Deterrence (solid line) and accomodation (dashed line) profits.

Given that deterrence ($\Pi_M(\theta_1^D)$) and accommodation (Π_1) profits move in the same direction according to changes in $\bar{\beta}$ or $\underline{\beta}$ (see Table 1.6.1), we were expected an ambiguous effect on the threshold value \underline{F} . Conversely, as shown in Table 1.6.2, it is immediate to see a clear path also for \underline{F} which is increasing in $\bar{\beta}$ ($\underline{\beta}$). Apparently, when $\bar{\beta}$ goes up, the decrease of deterrence profits is softened by a reduction of deterrence costs through the drop of accommodation profits.²³ This could be explained as a sort of position advantage of the incumbent platform.

1.7 Conclusions

This paper provides an analysis of vertical differentiation of two-sided platforms where competition prevails on one side of the market, namely on the individuals.

We provide a full characterization of the equilibrium for what concerns advertising, subscription fees, market shares and qualities, both for the monopoly and duopoly cases. In the comparison between the two market structures, three main results emerge. First, for each platform, if the profits maximizing advertising level is positive, then it is constant and it is just determined by the disutility parameter δ . This means that the strategic advertising choice is the same, regardless the market structure. However, in the duopoly structure, the total amount of advertising doubles the monopoly level. Second, in duopoly there is a full profit neutrality effect: there is a pass-through of advertising revenues into lower pay-per-view prices. This effect is reduced in the monopoly case. This result is strongly related to the issue of competitive bottlenecks and the prevailing competition on individuals' side. Finally, the monopoly platform chooses the maximum quality while duopoly platforms choose to maximally differentiate.

²³ Conversely in the case of an increase in $\underline{\beta}$ ($\bar{\beta}$), we observe a decrease of \underline{F} due to a raise of the opportunity costs of deterrence.

Furthermore, we focused on the role of competition by considering potential entry in the two-sided market and the associated behavior of an incumbent platform. We consider three different situations: a sequential duopoly, a sequential duopoly threaten by the possibility of entry by new competitors and, as last case, when the incumbent platform may decide to prevent the entry of a second one.

In the case of sequential duopoly threaten by entry, we extend the Shaked and Sutton (1982) result to a two-sided structure: under some conditions on individuals' heterogeneity, we show that of any n platforms offering distinct qualities, exactly two will have positive market shares on the buyers' side (audience) at equilibrium, covering the market. Therefore, the threat of entry shakes the equilibrium configuration of the sequential duopoly. Indeed, the Incumbent platform's quality might decrease, while the quality of the entrant platform might increase and quality differentiation may shrink. In this respect, the model predicts that competition, or the threat of entry, does not necessarily come out with a higher quality. However, we show that, for appropriate values of $\underline{F}(\delta, \bar{\beta}, \underline{\beta})$, entry deterrence is a feasible and profitable strategy for the Incumbent platform. Therefore a quality investment might be a deterrence strategy, restricting competition among platforms.

To conclude, let us point out that our result on quality partially depends on the cost structure used in this model. Under the assumption of fixed costs, monopoly profit function is convex in quality. One might expect that this shape strictly depends on the assumption of K , fixed cost of quality. In fact, in a single-side framework the standard model of vertical differentiation is solved with quadratic costs of quality, inducing concavity of profit function. However, in a two-sided setting the issue of concavity of profit function is more complex. As expected, linear cost of quality does not solve the problem of convexity of profit function. But, more surprisingly, even increasing costs of quality do not guarantee well-shaped monopoly profit function. For instance, quadratic cost of quality (see Weeds (2013)) do not make concave the monopoly profit function, for what concerns quality, without ad hoc assumptions on the derivatives. One possible way out would have been to have implicit quality cost functions (see Anderson (2007)), that, however, should have been unable to provide a close solution of the model. Therefore we chose to introduce a simplest cost function and a technological range bounding the levels of quality, allowing us to characterize the equilibrium configuration.²⁴

²⁴In Battaglion and Drufuca (2015) we consider also the case of a monopoly platform choosing the minimum quality.

Bibliography

- [1] Ambrus, Attila and Calvano, Emilio and Reisinger, Markus (2013) "Either or Both Competition: A "Two-Sided" Theory of Advertising with Overlapping Viewers", CSEF working papers, 378.
- [2] Anderson, Simon P. and Coate, Stephen (2005) "Market Provision of Broadcasting: a Welfare Analysis", *Review of Economic Studies*, 72: 947-972.
- [3] Anderson, Simon P. (2007) "Regulation of television advertising" In: Seabright, Paul and Von Hagen, Jurgen (eds), *The economic regulation of broadcasting markets*, Cambridge University Press, London.
- [4] Areeda, Herbert and Hovenkamp, Phillips E. (2014) *Antitrust Law: An Analysis of Antitrust Principles and their Application*, Aspen Publishers, 4th ed.
- [5] Armstrong, Mark (2006) "Competition in two-sided markets", *Rand Journal of Economics*, 37, 3: 668-691.
- [6] Battaggion, Maria Rosa and Drufuca, Serena M. (2015), "Broadcasters Competition: a Welfare Perspective", mimeo
- [7] Caillaud, Bernard and Jullien, Bruno (2001) "Competing cybermediaries", *European Economic Review*, 45: 797-808
- [8] Caillaud, Bernard and Jullien, Bruno (2003) "Chicken & Egg: Competition among Intermediation Service Providers", *The Rand Journal of Economics*, 34, 2: 309-328.
- [9] Calvano, Emilio and Polo, Michele (2014) "Strategic Differentiation by Business Models: Free-to-Air and Pay-Ts", Mimeo.
- [10] Collins, Richard (2007) "The BBC and public value" *Medien und Kommunikationswissenschaft*, 65(2) pp. 164–184.
- [11] Crampes, Claude and Harichtabalet, Carole and Jullien, Bruno (2009) "Advertising, Competition and Entry in Media Industries", *Journal of Industrial Economics*, 57, 1: 7-31.
- [12] Gabszewicz, Jean and Laussel, Didier and Sonnac, Nathalie (2004) "Programming and Advertising Competition in the Broadcasting Industry", *Journal of Economics & Management Strategy*, vol. 13(4): 657-669.
- [13] González-Maestre, Miguel and Martínez-Sánchez, Francisco (2013) "The role of platform quality and publicly owned platforms in the free-to-air broadcasting industry", *SERIEs*, vol. 5, 1:105-124.
- [14] Hamilton, James T. (2004) *All the news that's t to sell: How the market transforms information into news*, Princenton University Press.
- [15] Hung, Nguyen M. and Schmitt, Nicolas (1988) "Quality competition and threat of entry in duopoly," *Economics Letters*, Elsevier, vol. 27(3), pages 287-292.

- [16] Kremhelmer, Susanne and Zenger, Hans (2008) "Advertising and the screening role of mass media", *Information Economics and Policy*, Vol.20, 2: 107–119.
- [17] Lin, Panglang (2011) "Market provision of program quality in the television broadcasting industry", *The b.e. journal of economic analysis & policy*, 11(1), 122.
- [18] Mussa, Michael and Rosen, Sherwin (1978) "Monopoly and product quality", *Journal of Economic Theory*, Elsevier, vol. 18(2), pages 301-317.
- [19] Peitz, Martin and Valletti, Tommaso (2008) "Content and advertising in the media: pay-tv versus free-to-air", *International Journal of Industrial Organization*, 4: 949-965.
- [20] Ribeiro, Vitor M. and Correia-da-Silva, Joao and Resende, Joana (2014) "Nesting Vertical and Horizontal Differentiation in Two-sided Markets", FEP Working Papers, n.535: 1-37.
- [21] Rochet, Jean-Charles and Tirole, Jean (2006) "Two-sided markets: a progress report", *Rand Journal of Economics*, 37, 3: 645-667.
- [22] Roger, Guilleme (2010) "Two-sided competition and differentiation (with an application to media)", Discussion Papers 2010-27. School of Economics, The University of New South Wales.
- [23] Shaked, Avner and Sutton, John (1982) "Relaxing Price Competition Through Product Differentiation", *Review of Economic Studies*, XLIX: 3-13.
- [24] Shaked, Avner and Sutton, John (1983) "Natural oligopolies", *Econometrica*, 51(5), 1469-83.
- [25] Shapiro, Carl and Varian, Hal R (1998) *Information Rules: A strategic Guide to the Network Economy*, Harvard Business School Press.
- [26] Tirole, Jean (1988) *The Theory of Industrial Organization*, MIT Press, Cambridge (Mass.).
- [27] Weeds, Helen (2013) "Programme Quality in Subscription and Advertising-Funded Television", *mimeo*

Appendix

Proof Proposition 4

Proof. Platforms maximize profits, (1.4.8) and (1.4.7), subject to $a_i \geq 0$ with $i = H, L$. The first order conditions with respect to the advertising spaces a_i and subscription fees s_i are:

$$Ns_i \frac{\partial B_i}{\partial a_i} + r_i + a_i \frac{\partial r_i}{\partial a_i} \leq 0 \quad (1.7.1)$$

$$NB_i + Ns_i \frac{\partial B_i}{\partial s_i} + a_i \frac{\partial r_i}{\partial s_i} = 0 \quad (1.7.2)$$

with $i = H, L$.

Given (2.6.33) for platform H we have $r_H = \frac{NB_H \rho(a_H)}{a_H}$ and:

$$\begin{aligned} \frac{\partial r_H}{\partial s_H} &= \frac{1}{a_H} N \rho(a_H) \frac{\partial B_H}{\partial s_H} \\ \frac{\partial r_H}{\partial a_H} &= \frac{[NB_H \rho' + N \rho(a_H) \frac{\partial B_H}{\partial a_H}] a_H - NB_H \rho(a_H)}{a_H^2} \end{aligned}$$

Therefore optimality condition (1.7.2) and (1.7.1) rewrite:

$$B_H + (s_H + \rho(a_H)) \frac{\partial B_H}{\partial s_H} = 0 \quad (1.7.3)$$

$$B_H \rho'(a_H) + (\rho(a_H) + s_H) \frac{\partial B_H}{\partial a_H} \leq 0 \quad (1.7.4)$$

Since:

$$\frac{\partial B_H}{\partial s_H} = \delta \frac{\partial B_H}{\partial a_H}$$

(1.7.4) becomes:

$$\frac{\rho'(a_H)}{\delta} B_H + (\rho(a_H) + s_H) \frac{\partial B_H}{\partial s_H} \leq 0 \quad (1.7.5)$$

Together with (1.7.3), we obtain the following conditions:

$$\begin{cases} -B_H = (s_H + \rho(a_H)) \frac{\partial B_H}{\partial s_H} \\ (\frac{\rho'(a_H)}{\delta} - 1) B_H \leq 0 \end{cases} \quad (1.7.6)$$

If $a_H > 0$ the above inequality is satisfied with equality. Therefore, given that $\rho(a_H)$ is single-peaked, a_H is uniquely determined by the following condition:

$$\rho'(a_H^*) = \delta$$

Analogously, for platform L , if $a_L > 0$ we get:

$$\rho'(a_L^*) = \delta$$

□

Proof of Proposition 5

Proof. In the second stage of the game, with $\rho(a_i)$ concave, we obtain the equilibrium prices s_H^*, s_L^* and r_H^*, r_L^* as function of qualities, revenues per viewer and advertising. From condition (1.7.3) for platform H and the analogous condition for platform L , we get:

$$\begin{cases} s_H = \frac{s_L + \bar{\beta}(\theta_H - \theta_L) - \delta(a_H - a_L) - \rho(a_H)}{2} \\ s_L = \frac{s_H - \underline{\beta}(\theta_H - \theta_L) + \delta(a_H - a_L) - \rho(a_L)}{2} \end{cases} \quad (1.7.7)$$

Then, the solution of the above system becomes:

$$s_H^*(\theta_H, \theta_L, \rho(a_H), \rho(a_L)) = \frac{2}{3}\bar{\beta}(\theta_H - \theta_L) - \frac{1}{3}\underline{\beta}(\theta_H - \theta_L) - \frac{1}{3}\delta(a_H - a_L) - \frac{2}{3}\rho(a_H) - \frac{1}{3}\rho(a_L) \quad (1.7.8)$$

$$s_L^*(\theta_H, \theta_L, \rho(a_H), \rho(a_L)) = \frac{1}{3}\bar{\beta}(\theta_H - \theta_L) - \frac{2}{3}\underline{\beta}(\theta_H - \theta_L) + \frac{1}{3}\delta(a_H - a_L) - \frac{1}{3}\rho(a_H) - \frac{2}{3}\rho(a_L) \quad (1.7.9)$$

If we plug s_H^* and s_L^* in the demand function obtained at stage three, (1.4.3) and (1.4.4), we get:

$$\frac{\bar{\beta}}{\bar{\beta} - \underline{\beta}} - \frac{B_H^*(\theta_H, \theta_L, \rho(a_H), \rho(a_L))}{(\bar{\beta} - \underline{\beta})(\theta_H - \theta_L)} = \frac{(\underline{\beta} + \bar{\beta})(\theta_H - \theta_L) + \delta(a_H - a_L) - \rho(a_H) + \rho(a_L)}{3} \quad (1.7.10)$$

$$\frac{B_L^*(\theta_H, \theta_L, \rho(a_H), \rho(a_L))}{(\bar{\beta} - \underline{\beta})(\theta_H - \theta_L)} - \frac{\underline{\beta}}{\bar{\beta} - \underline{\beta}} = \frac{(\underline{\beta} + \bar{\beta})(\theta_H - \theta_L) + \delta(a_H - a_L) - \rho(a_H) + \rho(a_L)}{3} \quad (1.7.11)$$

Finally, considering

$$r_L((s_H, s_L, a_H, a_L, \theta_H, \theta_L)) = F^{-1}(1 - a_L)NB_L \quad (1.7.12)$$

$$r_H((s_H, s_L, a_H, a_L, \theta_H, \theta_L)) = F^{-1}(1 - a_H)NB_H \quad (1.7.13)$$

we end with:

$$\frac{\rho(a_H)}{a_H} N \left(\frac{r_H^*(\theta_H, \theta_L, \rho(a_H), \rho(a_L))}{3(\bar{\beta} - \underline{\beta})(\theta_H - \theta_L)} \right) \quad (1.7.14)$$

$$\frac{\rho(a_L)}{a_L} N \left(\frac{r_L^*(\theta_H, \theta_L, \rho(a_H), \rho(a_L))}{3(\bar{\beta} - \underline{\beta})(\theta_H - \theta_L)} \right) \quad (1.7.15)$$

If $a_L = a_H = a^*$ then $\rho(a_H) = \rho(a_L) = \rho(a^*)$, it will be straightforward to see:

$$s_H^*(\theta_H, \theta_L, a^*) = \frac{(2\bar{\beta} - \underline{\beta})(\theta_H - \theta_L)}{3} - \rho(a^*) > \frac{(\bar{\beta} - 2\underline{\beta})(\theta_H - \theta_L)}{3} - \rho(a^*) = s_L^*(\theta_H, \theta_L, a^*)$$

and

$$r_H^*(a, \rho) = \frac{\rho(a^*)}{a^*} N \left(\frac{(2\bar{\beta} - \underline{\beta})(\theta_H - \theta_L)}{3(\bar{\beta} - \underline{\beta})(\theta_H - \theta_L)} \right) > \frac{\rho(a^*)}{a^*} N \left(\frac{(\bar{\beta} - 2\underline{\beta})(\theta_H - \theta_L)}{3(\bar{\beta} - \underline{\beta})(\theta_H - \theta_L)} \right) = r_L^*(a, \rho)$$

Finally,

$$B_H^* = \frac{2\bar{\beta} - \underline{\beta}}{3(\bar{\beta} - \underline{\beta})} > \frac{\bar{\beta} - 2\underline{\beta}}{3(\bar{\beta} - \underline{\beta})} = B_L^*$$

□

Proof of Lemma 3

Proof. We have already stated that for $2\underline{\beta} < \bar{\beta}$ low-quality platform has a positive audience (see Section 1.4).

For $\bar{\beta} < 4\underline{\beta}$ we follow Shaked and Sutton (1982) with appropriate transformations to fit our two-sided structure.

From Section 1.4, we know that in equilibrium subscription fees are:

$$s_H^* = \frac{(2\bar{\beta} - \underline{\beta})(\theta_H - \theta_L)}{3} - \rho(a^*) \tag{1.7.16}$$

$$s_L^* = \frac{(\bar{\beta} - 2\underline{\beta})(\theta_H - \theta_L)}{3} - \rho(a^*) \tag{1.7.17}$$

Looking at equilibrium subscription fees, it is straightforward to see that the "profit neutrality" result still holds. Advertising revenues per viewers $\rho(a^*)$ are entirely spent in reducing subscription fees s_i^* . Due to this neutrality result, we can apply the following transformation to equilibrium demands in order to have a single price, which is always positive:

$$p_i = s_i + \rho(a_i) > 0$$

In this way we are able to obtain a framework similar to the one of Shaked and Sutton (1982). We consider a situation of n platforms ordered by their quality $\theta_1 < \theta_2 < \dots < \theta_n$ competing for an uniform audience (same assumptions as in previous sections) covering the entire market²⁵.

Given the equilibrium of stage 2 ($a_1 = a_2 = \dots = a_n = a^*$), indifferent viewers are defined as follows:

²⁵As in Shaked and Sutton (1982), the assumption of market coverage does not change the result of the proof. However, for the sake of simplicity, we assume it throughout the proof.

$$\begin{aligned}
\beta_2 &= \frac{p_2 - p_1}{(\theta_2 - \theta_1)} \\
\beta_3 &= \frac{p_3 - p_2}{(\theta_3 - \theta_2)} \\
&\vdots \\
\beta_n &= \frac{p_n - p_{n-1}}{(\theta_n - \theta_{n-1})}
\end{aligned}$$

Demands become:

$$\begin{aligned}
NB_1 &= N \left(\frac{p_2 - p_1}{(\theta_2 - \theta_1)} - \underline{\beta} \right) \\
NB_2 &= N \left(\frac{p_3 - p_2}{(\theta_3 - \theta_2)} - \frac{p_2 - p_1}{(\theta_2 - \theta_1)} \right) \\
&\vdots \\
NB_n &= N \left(\bar{\beta} - \frac{p_n - p_{n-1}}{(\theta_n - \theta_{n-1})} \right)
\end{aligned}$$

Platforms' Revenues are:

$$\begin{aligned}
R_1 &= p_1 NB_1 = p_1 N (\beta_2 - \underline{\beta}) \\
R_2 &= p_2 NB_2 = p_2 N (\beta_3 - \beta_2) \\
&\vdots \\
R_n &= p_n NB_n = p_n N (\bar{\beta} - \beta_n)
\end{aligned}$$

Profit maximization w.r.t. quality gives the following optimality conditions:

$$\begin{aligned}
(\beta_2 - \underline{\beta}) + p_1 \left(\frac{-1}{(\theta_2 - \theta_1)} \right) &= 0 \\
(\beta_3 - \beta_2) + p_2 \left(-\frac{1}{(\theta_3 - \theta_2)} - \frac{1}{(\theta_2 - \theta_1)} \right) &= 0 \\
&\vdots \\
(\bar{\beta} - \beta_n) + p_n \left(-\frac{1}{(\theta_n - \theta_{n-1})} \right) &= 0
\end{aligned}$$

Recall from indifference conditions:

$$\beta_{n-1} = \frac{p_{n-1} - p_{n-2}}{(\theta_{n-1} - \theta_{n-2})} = p_{n-1} \frac{1}{(\theta_{n-1} - \theta_{n-2})} - p_{n-2} \frac{1}{(\theta_{n-1} - \theta_{n-2})}$$

which can be written as:

$$p_{n-1} \frac{1}{(\theta_{n-1} - \theta_{n-2})} = \beta_{n-1} + p_{n-2} \frac{1}{(\theta_{n-1} - \theta_{n-2})}$$

Hence we re-write optimality condition for $(n-1)$ th platform :

$$\begin{aligned}
(\beta_n - \beta_{n-1}) - p_{n-1} \frac{1}{(\theta_n - \theta_{n-1})} - \beta_{n-1} - p_{n-2} \frac{1}{(\theta_{n-1} - \theta_{n-1})} &= 0 \\
\beta_n - 2\beta_{n-1} - p_{n-1} \frac{1}{(\theta_n - \theta_{n-2})} - p_1 \frac{1}{(\theta_{n-1} - \theta_{n-2})} &= 0
\end{aligned}$$

This condition implies that:

$$\beta_n > 2\beta_{n-1} \quad (1.7.18)$$

We do the same for the optimality condition of n th platform , obtaining:

$$\bar{\beta} - 2\beta_n - p_{n-1} \frac{1}{(\theta_n - \theta_{n-1})} = 0$$

which implies:

$$\bar{\beta} > 2\beta_n \quad (1.7.19)$$

Taking conditions (1.7.18) and (1.7.19) together we get:

$$\bar{\beta} \geq 2\beta_n > 4\beta_{n-1}$$

which implies:

$$\bar{\beta} > 4\beta_{n-1}$$

Having assumed $\bar{\beta} < 4\underline{\beta}$ we end up with:

$$4\beta_{n-1} < \bar{\beta} < 4\underline{\beta}$$

This inequality implies:

$$\beta_{n-1} < \underline{\beta} \quad (1.7.20)$$

The inequality (1.7.20) implies that market is completely covered by the $(n-1)$ th and the n th platform, namely those with the highest qualities. This means that all other platforms face a zero market share on viewers' side.

Notice that we can also show that in a triopoly case, given $\bar{\beta} < 4\underline{\beta}$, only the two platform with highest qualities survive and cover the market. We consider the same framework as in the duopoly case but with three platforms ranked by quality $\theta_1 < \theta_2 < \theta_3$. Under market coverage, indifferent consumers are identified by:

$$\begin{aligned}
\beta_{12} &= \frac{\delta(a_2 - a_1) + (s_2 - s_1)}{\theta_2 - \theta_1} \\
\beta_{23} &= \frac{\delta(a_3 - a_2) + (s_3 - s_2)}{\theta_3 - \theta_2}
\end{aligned}$$

Demands from the consumers' side are respectively:

$$\begin{aligned}
NB_1 &= N \frac{1}{\bar{\beta} - \underline{\beta}} (\beta_{12} - \underline{\beta}) = \\
N \frac{1}{\bar{\beta} - \underline{\beta}} &\left(\frac{\delta(a_2 - a_1) + (s_2 - s_1) - \underline{\beta}(\theta_2 - \theta_1)}{\theta_2 - \theta_1} \right)
\end{aligned}$$

$$\begin{aligned}
NB_2 &= N \frac{1}{\bar{\beta} - \underline{\beta}} (\beta_{23} - \beta_{12}) = \\
N \frac{1}{\bar{\beta} - \underline{\beta}} &\left(\frac{\delta (a_3 - a_2) + (s_3 - s_2)}{\theta_3 - \theta_2} - \frac{\delta (a_2 - a_1) + (s_2 - s_1)}{\theta_2 - \theta_1} \right) \\
NB_3 &= N \frac{1}{\bar{\beta} - \underline{\beta}} (\bar{\beta} - \beta_{23}) = \\
N \frac{1}{\bar{\beta} - \underline{\beta}} &\left(\frac{\bar{\beta} (\theta_3 - \theta_2) - \delta (a_3 - a_2) - (s_3 - s_2)}{\theta_3 - \theta_2} \right)
\end{aligned}$$

Resolution for stages 3 and 2 is standard. From optimality conditions we obtain:

$$s_i = \frac{-B_i}{\partial B_i / \partial s_i} - \rho$$

where $\rho = \rho(a_i)$. Since in equilibrium $a_1 = a_2 = a_3 = a^*$ and $\rho = \rho(a^*) = \rho^*$, we get the following system:

$$\begin{aligned}
s_1 &= \frac{s_2 - \underline{\beta} (\theta_2 - \theta_1)}{2} - \frac{\rho^*}{2} \\
s_2 &= \frac{s_3 (\theta_2 - \theta_1) + s_1 (\theta_3 - \theta_2)}{2 (\theta_3 - \theta_1)} - \frac{\rho^*}{2} \\
s_3 &= \frac{s_2 + \bar{\beta} (\theta_3 - \theta_2)}{2} - \frac{\rho^*}{2}
\end{aligned}$$

Equilibrium access prices are:

$$\begin{aligned}
s_1^* &= \frac{1}{6 (\theta_3 - \theta_1)} \left((\bar{\beta} - \underline{\beta}) (\theta_2 - \theta_1) (\theta_3 - \theta_2) - 3\underline{\beta} (\theta_3 - \theta_1) (\theta_2 - \theta_1) \right) - \rho^* \\
s_2^* &= \frac{1}{3 (\theta_3 - \theta_1)} \left((\bar{\beta} - \underline{\beta}) (\theta_3 - \theta_2) (\theta_2 - \theta_1) - \rho^* \right) \\
s_3^* &= \frac{1}{6 (\theta_3 - \theta_1)} \left((\bar{\beta} - \underline{\beta}) (\theta_3 - \theta_2) (\theta_2 - \theta_1) + 3\bar{\beta} (\theta_3 - \theta_2) (\theta_3 - \theta_1) \right) - \rho^*
\end{aligned}$$

Given s_1^* , s_2^* and s_3^* , we check whether or not $\beta_{12} > \underline{\beta}$ under the condition of $4\underline{\beta} > \bar{\beta}$. If this is the case, platform 1 faces zero demand and platforms 2 and 3 cover the whole consumer market, confirming the result of Shaked and Sutton (1982).

$$\begin{aligned}
\beta_{12} &= \frac{(s_2^* - s_1^*)}{\theta_2 - \theta_1} \\
&= \frac{1}{6 (\theta_3 - \theta_1)} \left((\bar{\beta} - \underline{\beta}) (\theta_3 - \theta_2) + 3\underline{\beta} (\theta_3 - \theta_1) \right) \\
\beta_{12} - \underline{\beta} &= \frac{1}{6 (\theta_3 - \theta_1)} \left((\bar{\beta} - \underline{\beta}) (\theta_3 - \theta_2) - 3\underline{\beta} (\theta_3 - \theta_1) \right)
\end{aligned}$$

Which is negative since $(\bar{\beta} - \underline{\beta}) < 3\underline{\beta}$ and $(\theta_3 - \theta_2) < (\theta_3 - \theta_1)$.

Hence $\beta_{12} < \underline{\beta}$: the two platforms with highest qualities cover the market, leaving no room for the low-quality platform.

□

Numerical Simulation

Table 1.7.1: Monopoly ($\Pi_M(\theta_1^D)$) and Duopoly (Π_1) Profits for $\delta = 0.5$

$\bar{\beta}$	$\underline{\beta} = \frac{1}{4}\bar{\beta}$	$\underline{\beta} = \frac{1}{3}\bar{\beta}$	$\underline{\beta} = \frac{1}{2.00001}\bar{\beta}$
0.00001	$\Pi_1 = 12.25F$ $\Pi_M(\theta_1^D) = \frac{(27.0F+0.125)^2}{1.08 \times 10^7 F + 25000}$	$\Pi_1 = 25.0F$ $\Pi_M(\theta_1^D) = \frac{(54.0F+0.125)^2}{2.16 \times 10^7 F + 25000}$	$\Pi_1 = 9.0001 \times 10F$ $\Pi_M(\theta_1^D) = \frac{(1.8 \times 10^{11} F + 0.125)^2}{7.2001 \times 10^{16} F + 25000}$
0.5	$\Pi_1 = 12.25F$ $\Pi_M(\theta_1^D) = \frac{(27.0F+0.125)^2}{216.0F+0.5}$	$\Pi_1 = 25.0F$ $\Pi_M(\theta_1^D) = \frac{(54.0F+0.125)^2}{432.0F+0.5}$	$\Pi_1 = 9.0001 \times 10F$ $\Pi_M(\theta_1^D) = \frac{(1.8 \times 10^{11} F + 0.125)^2}{1.44 \times 10^{12} F + 0.5}$
1	$\Pi_1 = 12.25F$ $\Pi_M(\theta_1^D) = \frac{(27.0F+0.125)^2}{108F+0.25}$	$\Pi_1 = 25.0F$ $\Pi_M(\theta_1^D) = \frac{(54.0F+0.125)^2}{216F+0.25}$	$\Pi_1 = 9.0001 \times 10F$ $\Pi_M(\theta_1^D) = \frac{(1.8 \times 10^{11} F + 0.125)^2}{7.2001 \times 10^{11} F + 0.25}$
5	$\Pi_1 = 12.25F$ $\Pi_M(\theta_1^D) = \frac{(27.0F+0.125)^2}{21.6F+0.05}$	$\Pi_1 = 25.0F$ $\Pi_M(\theta_1^D) = \frac{(54.0F+0.125)^2}{43.2F+0.05}$	$\Pi_1 = 9.0001 \times 10F$ $\Pi_M(\theta_1^D) = \frac{(1.8 \times 10^{11} F + 0.125)^2}{1.44 \times 10^{11} F + 0.05}$
12	$\Pi_1 = 12.25F$ $\Pi_M(\theta_1^D) = \frac{(27.0F+0.125)^2}{9.0F+2.0833 \times 10^{-2}}$	$\Pi_1 = 25.0F$ $\Pi_M(\theta_1^D) = \frac{(54.0F+0.125)^2}{18.0F+2.0833 \times 10^{-2}}$	$\Pi_1 = 9.0001 \times 10F$ $\Pi_M(\theta_1^D) = \frac{(1.8 \times 10^{11} F + 0.125)^2}{6.0001 \times 10^{10} F + 2.0833 \times 10^{-2}}$

Table 1.7.2: Values of $\underline{F}(\delta, \underline{\beta}(\bar{\beta}))$ for $\delta = 0.5$

$\bar{\beta}$	$\underline{\beta} = \frac{1}{4}\bar{\beta}$	$\underline{\beta} = \frac{1}{3}\bar{\beta}$	$\underline{\beta} = \frac{1}{2.00001}\bar{\beta}$
0.00001	$\underline{F} = 5.102 \times 10^{-8}$	$\underline{F} = 2.5 \times 10^{-8}$	$\underline{F} = 6.9444 \times 10^{-18}$
0.5	$\underline{F} = 3.0226 \times 10^{-3}$	$\underline{F} = 1.4726 \times 10^{-3}$	$\underline{F} = 4.0093 \times 10^{-13}$
1	$\underline{F} = 9.0989 \times 10^{-3}$	$\underline{F} = 4.3611 \times 10^{-3}$	$\underline{F} = 1.1236 \times 10^{-12}$
5	$\forall F > 0$	$\forall F > 0$	$\forall F > 0$
12	$\forall F > 0$	$\forall F > 0$	$\forall F > 0$

Chapter 2

Broadcasters Competition on Quality: a Welfare Perspective ¹

2.1 Introduction

Television broadcasting has a long history of salient regulation problems which have been recently emphasized by the convergence among Internet, computer software and telecommunications. Conventionally, regulatory issues in media markets are classified into economic and non-economic features. Where the former are related to the structure of the supply side: the definition of the relevant market, the assessment of the degree of concentration and competition, the impact of the ownership structure and the conditions of the access to the broadcasting service. While the latter mainly focus on the broadcasting contents and the control of advertising. (Rowat (2007)). The interplay among these economic and non-economic issues, which is a peculiar feature of broadcasting, deserves a closer attention from policy makers and antitrust authorities.

In this respect, our paper would provide a unified framework to deal with all these issues and to analyze broadcasting competition with particular concern on quality, prices, share of audience and consumers' surplus. More precisely, it analyzes the role of competition in a two-sided market characterized by vertical differentiation.

Quality is a first ingredient of our model. Despite the fact that quality is a relevant characteristic of broadcasting market, it lacks a clear and common economic definition (Born and Prosser (2001)). At a first glance quality could be associated with the technological innovations that have deeply affected broadcasting, such as higher-definition images or interactive services. In this perspective, quality of broadcasting can be interpreted in the standard vertical approach. However if we focus on content, quality is more complex to be defined. As matter of facts, content's quality can be related to accuracy, truth, impartiality and immediacy of information that helps form public opinion, expresses minority voices and performs a watchdog role for the public interest.² For instance Collins (2007), in the public service broadcasting debate, associates quality to the purpose of providing not only entertainment but also education, learning and cultural excellence.³ However it is worth to notice that viewers' perception might differ concerning these dimensions. Indeed, audience has also a taste for variety of broadcasting output, including cultural programme, popular genres, and sport events. Therefore an increase in content quality does not necessarily translate into an upward shift of demand and audience. Hence, some dimensions of content's quality may encompass an horizontal feature.

¹This chapter refers to the joint paper Battagion and Drufuca 2015 "Broadcasters Competition on Quality: a Welfare Perspective", mimeo.

²Mephram (1990) argues that there is a general rule for assessing television quality, and that is 'whether or not [its production] is governed by an ethic of truth-telling'.

³Ellmann (2014) distinguishes between "soft" and "hard" attributes to media consumption. He defines "hard" or informative attributes of media those generating positive social externalities, while "soft" attributes are those with only private value, such as graphic quality, sensationalism and entertainment.

Nevertheless, in a specific genre, all viewers prefer high quality contents rather than low quality contents, which implies vertical competition on the market. Given these considerations, in the present paper we assume that broadcasters provide vertically differentiated output with respect to quality.

A second important aspect we would like to address is the role of competition in a two-sided market. The reason to consider this kind of market structure is that broadcasting networks compete on two sides, namely audience and advertisers, in order to maximize profits. Advertising is typically perceived as a nuisance by the audience and it represents a negative externality, while the audience exerts a positive externality on advertisers. Therefore, competition has a broader meaning with respect to the standard industrial organization and might generate different results and policy implications. In our setup, viewers are single-homing, while advertisers are multi-homing, meaning that platforms have monopoly power in providing access to their single-homing customers. In this respect, platforms act as "bottlenecks" between advertisers and consumers by offering sole access to their respective set of consumers. This assumption is crucial to explain the prevailing competition on the consumer side.⁴ We also model advertisers as non-strategic: their payoffs do not depend on what other advertisers do but rather on benefits related to market demand. This behavior suits the case of informative advertising. Finally, it is well known that media markets are characterized by a broad range of business models, both under private and public ownership:⁵ free-to-air TV, where broadcast platforms are only financed through advertising revenues, pay TV, where broadcast stations are financed through subscription revenues, and a mixed regime, where broadcast platforms are financed through both subscription fees and advertising. We consider a very general framework in which platforms are financed both by advertising and subscription fees.⁶

As previously mentioned, we provide a model of platforms' competition in a framework of vertical differentiation. In a context where platforms endogenously provide their quality levels, we calculate the equilibrium values of advertising, the optimal subscription fees for viewers and the provision of quality. In particular, we take into account a single-channel and multi-channel monopoly, as well as a duopoly. In our analysis, we want to stress the importance of having a market which is never covered *ex-ante*. We believe indeed that the potential demand has a relevant role and might shake the equilibrium configuration, in terms of price, quality, audience size and advertising. Furthermore, the uncovered market configuration fits very well the case of broadcasting market, which is characterized by continuous technological turmoil with the creation of new market segments. We also calculate the consumers' surplus for each market configuration to figure out whether the interplay among contents quality, subscription fees and advertising might benefit the audience.

To anticipate the results, we show that viewers are always better off when they are free to choose among channels of different qualities. In our framework, there are two forces at stake. Higher quality induces consumers to pay higher subscription fees to join the platform. In turn, the platform can extract a surplus on the advertiser side and "invest" them in a reduction of subscription fees, implying that advertisers cross-subsidize single-homing consumers. Therefore a sort of substitution between quality and advertising arises. We also show that competition is beneficial for the audience, resulting in a viewers' surplus which is larger in the duopoly configuration than in the monopoly, even when both provide high and low-quality channels. Finally, we illustrate that the chance of catching extra viewers, as the uncovered market share, disciplines the platforms' behavior in duopoly making consumers' surplus higher.

⁴For a further discussion on the role of the single-homing or multi-homing assumption, see Roger (2010).

⁵In Italy, for instance, there exists a public broadcaster financed by subscription fees (canone RAI) as well as advertising revenues. At the same time, there exist both free-to-air private operators such as Mediaset that are totally financed through advertising and private pay-TV providers financed through subscription fees and advertising revenues (e.g., Sky).

⁶Subscription fees are set in general terms and could be both positive or negative, encompassing the possibility of subsidization.

2.1.1 Related Literature

Our paper belongs to the literature of vertically differentiated two-sided markets dealing with welfare issues. In this stream, Armstrong (2006) and Weeds (2013) provide a model with endogenous quality provision in the two-sided context of digital broadcasters. By comparing competition in two different regimes, free-to-air and pay TV, they show that program quality is higher for pay TV, which is also optimal from a social point of view. In a similar setting, Anderson (2007) analyzes the effect of an advertising cap on the quality provision of a monopoly broadcaster and on welfare. He shows that advertising time restrictions may improve welfare but may decrease program quality.⁷ Kind et al. (2007) perform a welfare analysis with endogenous quality provision and find that a merger between TV channels may be welfare improving. More recently, Lin (2011) extended the analysis to direct competition between different business model, where one platform operates as a free-to-air TV while the second as a pay-TV. In this framework, he shows that platforms vertically differentiate their programs according to the degree of viewers' dislike of advertising. In the same approach, Gonzales-Mestre and Martinez-Sanchez (2013) study how public-owned platforms affects the program quality provision, the social welfare and the optimal level of advertising. Differently, from our model, all the above contributions focus on the duopoly case, neglecting monopoly behavior with the exception of Anderson (2007). Furthermore, the duopoly setting is always assumed to be covered, preventing any welfare consideration about the role of increasing demand. Conversely, we relax this assumption introducing a set up of uncovered market. We also provide a comparison between the uncovered and the covered market structure from a welfare perspective.

The paper is organized as follows. Section 2.2 illustrates the case of a multi-channel monopoly broadcaster and Section 2.3 focuses on the welfare comparison between the multi-channel monopoly broadcaster and a single-channel one. Then, Section 2.4 introduces competition among broadcasters, while Section 2.5 deals with the welfare effects. Finally we provide some conclusions in Section 2.6.

2.2 The Multi-Channel Broadcaster

For the sake of exposition we describe first the case of a multi-product monopoly platform and second the duopoly case.⁸

A multiproduct monopoly platform can provide vertical differentiated *channels* to a uniform distribution of individuals (viewers⁹) of mass 1. We refer to this platform as the multi-channel broadcaster.

Individuals are assumed to be single-homing. The utility of an individual accessing platform's channel i is:

$$u_i = V - \delta a_i + \beta \theta_i - s_i \quad (2.2.1)$$

and zero otherwise. V is the utility of accessing the platform independently of its quality. The channel's quality is denoted by the parameter θ_i which belongs to a technological range $\Theta = [\underline{\theta}, \bar{\theta}]$ with $\bar{\theta} > \underline{\theta} > 0$. Individuals have a private valuation for information expressed by the parameter $\beta \sim U[0, 1]$ which can be interpreted as their willingness to pay for quality. Moreover, they incur in a nuisance cost δa_i due to the presence of advertising on the channels.¹⁰ Finally s_i stands for the subscription charge.

If the platform provides two channels of different quality, θ_H and θ_L (with $\theta_H > \theta_L$) it obtains the following audience shares:

⁷Although without a specific reference to quality provision, Dukes (2004) and Anderson and Coate (2005) show that monopoly media ownership may increase welfare.

⁸The model in this section builds on that of Battaglion and Drufuca (2014).

⁹We consider a broadcasting market, which well fits our setting. However, in principle this model might be referred also to a broader range media (newspapers, as example).

¹⁰This cost depends on the intensity of advertising on the channel a_i and on a parameter of viewers' aversion to ads δ . This parameter is assumed to be invariant across individuals.

$$B_H = 1 - \beta_{HL} = 1 - \frac{\delta(a_H - a_L)}{(\theta_H - \theta_L)} - \frac{(s_H - s_L)}{(\theta_H - \theta_L)} \quad (2.2.2)$$

$$B_L = \beta_{HL} - \beta_{0L} = \frac{\delta(a_H - a_L)}{(\theta_H - \theta_L)} + \frac{(s_H - s_L)}{(\theta_H - \theta_L)} - \left(\frac{\delta a_L - V}{\theta_L} - \frac{s_L}{\theta_L} \right) \quad (2.2.3)$$

where β_{HL} and β_{0L} characterize respectively the individual indifferent between the two channels and the one indifferent between accessing the low-quality channel or not accessing at all.

Advertisers are producers of mass 1 who access the platform to advertise their products to individuals. They sell products of quality α that are produced at constant marginal costs set equal to zero. Product quality α is distributed on an interval $[0, 1]$ according to a distribution function $F(\alpha)$.¹¹ Individuals have a willingness to pay α for a good of quality α . Each producer has monopoly power and can therefore extract the full surplus from individuals by selling its product at price equal to α . As standard in this class of models, we assume advertising to be *informative* and that consumers watching an advertisement always buy the good. Hence, we refer to producers as advertisers. Differently from viewers, advertisers are allowed to multi-home. Advertisers have to pay an advertising charge r_i endogenously determined for each channel. Due to the assumption of single homing on the viewers' side, each channel behaves as a "monopoly" in carrying its audience to advertisers. Therefore, r_i is set by the platform in order to leave the marginal advertiser with zero profit:

$$\alpha_i = \frac{r_i}{NB_i} \quad (2.2.4)$$

Thus, the amount of advertising for each channel is the share of advertisers with $\alpha > \alpha_i$:

$$a_H = 1 - F\left(\frac{r_H}{B_H}\right) \quad (2.2.5)$$

$$a_L = 1 - F\left(\frac{r_L}{B_L}\right) \quad (2.2.6)$$

The platform sets advertising spaces and subscription prices (unconstrained) and it can provide its channels' quality θ_H and θ_L by incurring a fixed cost K .¹² In other words, once the cost is incurred, the higher-quality outlet can be provided to individuals without any additional charges. Notice that since our costs are also fixed in quantity, they meet the requirement of separability.

The multi-product media platform collects revenues from both individuals and advertisers:

$$\Pi_{MP} = (B_H s_H + B_L s_L) + a_H r_H + a_L r_L - 2K \quad (2.2.7)$$

Then, according to the literature, we define the advertising revenues per individual as:

$$\rho(a_i) = \frac{a_i r_i}{B_i} = \frac{a_i F^{-1}(1 - a_i) N B_i}{B_i} = a_i F^{-1}(1 - a_i) \quad (2.2.8)$$

We assume $\rho(a_i)$ to be concave on the interval $a \in [0, 1]$. Given that $\rho(a_i) = 0$ for $a_i = 0$ and $a_i = 1$, the function is single-peaked. Hence, profits rewrite as follow:

$$\Pi_{MP} = B_H(s_H + \rho(a_H)) + B_L(s_L + \rho(a_L)) - 2K \quad (2.2.9)$$

We consider a three-stage game. First the monopoly platform chooses the levels of quality. Second, it sets subscription fees and advertising spaces. Finally, in the third stage, viewers and advertisers simultaneously decide whether to join a channel.

¹¹In the discussion of our results, we will consider also the special case of a uniform distribution of advertisers.

¹²This assumption fits very well the structure of the ICT and media markets, where there is a prominent role of fixed costs compared to marginal ones (see e.g., Shapiro and Varian (1998) and Areeda and Hovenkamp (2014)).

2.2.1 Subscription Fees and Advertising Intensities

Having defined the demand function of viewers and advertisers, for given prices we solve the game backwards, from stage three. This determines how advertising charges react to pay-per-view prices s_i and to advertising levels a_i :

$$r_H(s_H, s_L, a_H, a_L, \theta_H, \theta_L) = F^{-1}(1 - a_H) \left(\frac{\theta_H - \theta_L - (s_H - s_L) - \delta(a_H - a_L)}{\theta_H - \theta_L} \right) \quad (2.2.10)$$

$$r_L(s_H, s_L, a_H, a_L, \theta_H, \theta_L) = F^{-1}(1 - a_L) \left(\frac{(s_H - s_L) + \delta(a_H - a_L)}{\theta_H - \theta_L} - \frac{s_L + \delta a_L - V}{\theta_L} \right) \quad (2.2.11)$$

The commercial multi-channel broadcaster relies on advertising revenues and subscription fees to fund its services.

$$\begin{cases} \max_{a_H, a_L, s_H, s_L} \Pi_{MP} = \pi_L + \pi_H = B_H(s_H + \rho(a_H)) + B_L(s_L + \rho(a_L)) - 2K \\ s.t. a_H \geq 0 \\ a_L \geq 0 \end{cases}$$

The platform maximizes profits (2.2.9), with respect to advertising intensity (a_H, a_L) and subscription fees (s_H, s_L) for each channel, subject to a positivity constraint on advertising. The following Proposition summarizes results regarding advertising.

Proposition 8. *The multi-channel monopoly broadcaster chooses the same advertising intensity, independently of quality and subscription revenues:*

$$\rho'(a_i) = \delta$$

for $i = H, L$.

Proof. First order conditions with respect to the advertising spaces and subscription fees are respectively, for $i, j = H, L$ with $i \neq j$:

$$\begin{aligned} \frac{\partial \pi_{MP}}{\partial s_i} &= \frac{\partial B_i}{\partial s_i}(s_i + \rho_i) + B_i \left(1 + \frac{\partial \rho_i}{\partial s_i}\right) + \frac{\partial B_j}{\partial s_i}(s_j + \rho_j) + B_j \left(\frac{\partial \rho_j}{\partial s_i}\right) = 0 \\ \frac{\partial \pi_{MP}}{\partial a_i} &= \frac{\partial B_i}{\partial a_i}(s_i + \rho_i) + B_i \left(\frac{\partial s_i}{\partial a_i} + \frac{\partial \rho_i}{\partial a_i}\right) + \frac{\partial B_j}{\partial a_i}(s_j + \rho_j) + B_j \left(\frac{\partial s_j}{\partial a_i} + \frac{\partial \rho_j}{\partial a_i}\right) \leq 0 \end{aligned}$$

where $\rho_i = \rho(a_i)$ to simplify notation. Given the construction of advertising revenues per individual (see equation (2.2.8)), we have that $\frac{\partial \rho_i}{\partial a_j} = 0$. Moreover $\frac{\partial s_i}{\partial a_i} = 0$ and $\frac{\partial s_i}{\partial a_j} = 0$. Hence, first order conditions simplify as follows:

$$\begin{aligned} \frac{\partial \pi_{MP}}{\partial s_i} &= \frac{\partial B_i}{\partial s_i}(s_i + \rho_i) + B_i \left(1 + \frac{\partial \rho_i}{\partial s_i}\right) + \frac{\partial B_j}{\partial s_i}(s_j + \rho_j) + B_j \left(\frac{\partial \rho_j}{\partial s_i}\right) = 0 \\ \frac{\partial \pi_{MP}}{\partial a_i} &= \frac{\partial B_i}{\partial a_i}(s_i + \rho_i) + B_i \left(\frac{\partial \rho_i}{\partial a_i}\right) + \frac{\partial B_j}{\partial a_i}(s_j + \rho_j) \leq 0 \end{aligned}$$

It is easy to show that $\frac{\partial B_H}{\partial a_H} = \delta \frac{\partial B_H}{\partial s_H}$, $\frac{\partial B_L}{\partial a_L} = \delta \frac{\partial B_L}{\partial s_L}$, $\frac{\partial B_H}{\partial a_L} = \delta \frac{\partial B_H}{\partial s_L}$ and $\frac{\partial B_L}{\partial a_H} = \delta \frac{\partial B_L}{\partial s_H}$. FOCs rewrite as follows

$$\frac{\partial \pi_{MP}}{\partial s_H} = \frac{\partial B_H}{\partial s_H}(s_H + \rho_H) + B_H + \frac{\partial B_L}{\partial s_H}(s_L + \rho_L) = 0 \quad (2.2.12)$$

$$\frac{\partial \pi_{MP}}{\partial s_L} = \frac{\partial B_L}{\partial s_L}(s_L + \rho_L) + B_L + \frac{\partial B_H}{\partial s_L}(s_H + \rho_H) = 0 \quad (2.2.13)$$

$$\frac{\partial \pi_{MP}}{\partial a_H} = \delta \frac{\partial B_H}{\partial s_H}(s_H + \rho_H) + B_H \rho'_H + \delta \frac{\partial B_L}{\partial s_H}(s_L + \rho_L) \leq 0 \quad (2.2.14)$$

$$\frac{\partial \pi_{MP}}{\partial a_L} = \delta \frac{\partial B_L}{\partial s_L}(s_L + \rho_L) + B_L \rho'_L + \delta \frac{\partial B_H}{\partial s_L}(s_H + \rho_H) \leq 0 \quad (2.2.15)$$

By substitution we get from (2.2.14) and (2.2.15)

$$\begin{aligned} B_H \rho'_H + \delta(-B_H) &\leq 0 \\ B_L \rho'_L + \delta(-B_L) &\leq 0 \end{aligned}$$

If $a_i > 0$ for $i = H, L$, then

$$\rho'(a_H^*) = \delta \quad (2.2.16)$$

$$\rho'(a_L^*) = \delta \quad (2.2.17)$$

□

According to Proposition 8 an optimal decision is to set a fixed advertising space for each channel just depending on the disutility of the viewers, δ . Moreover, the multi-channel broadcaster does not set the maximum intensity of advertising ($a_i = 1$) or the amount that maximize revenues per viewer, i.e. $\rho'(a_i) = 0$. This result is in line with the literature dealing with the issue of bottlenecks, suggesting that competition just focuses on the audience side. From optimality conditions (2.2.12) and (2.2.13), given a_H^* and a_L^* , we obtain equilibrium subscription fees, s_H^* and s_L^* , and shares on viewers' side, B_H^* and B_L^* , as function of qualities, revenues per viewer and advertising level:

$$s_H^* = \frac{\theta_H + V - a^* \delta - \rho(a^*)}{2} \quad (2.2.18)$$

$$s_L^* = \frac{\theta_L + V - a^* \delta - \rho(a^*)}{2} \quad (2.2.19)$$

$$B_H^* = \frac{1}{2} \quad (2.2.20)$$

$$B_L^* = \frac{1}{2} - \left(\frac{\theta_L - V + \delta a^* - \rho(a^*)}{2\theta_L} \right) \quad (2.2.21)$$

The above values show a *profit neutrality* result, since revenues from the advertising side are counterbalanced by a decrease on the subscription fees, irrespective of the channel. Moreover, given that subscription fees positively depend on quality, a sort of substitutability between advertising and quality emerges. It is relevant to notice that the high quality channel always covers half of the viewers' market, while the audience of the low quality channel relies on quality, fees and advertising. If the monopoly would cover the whole market, it will equally divide the audience between the two channels. Otherwise the low quality channel has always less viewers.

Recall that advertising revenues $\rho(a^*)$ depend on the distribution function of advertisers. In this respect, we can get a sharper intuition of our results by assuming a specific type of distribution. In particular we consider the case of a uniform distribution of advertisers $\alpha \sim U(0, 1)$, obtaining the following equilibrium values:

$$a_H^* = a_L^* = a^* = \frac{1 - \delta}{2} \quad (2.2.22)$$

$$s_H^* = \frac{\theta_H + V - \frac{(1-\delta)(1+3\delta)}{4}}{2}$$

$$s_L^* = \frac{\theta_L + V - \frac{(1-\delta)(1+3\delta)}{4}}{2}$$

$$\begin{aligned}
B_H^* &= \frac{1}{2} \\
B_L^* &= \frac{1}{2} - \frac{\theta_L - V - (\frac{1-\delta}{2})^2}{2\theta_L}
\end{aligned}$$

In the uniform case equilibrium fees and advertising intensity just depend on quality, disutility from advertising δ and V .

2.2.2 Quality

At stage 1, the multichannel platform chooses quality levels.¹³ Its profits are:

$$\pi_{MP} = \frac{\theta_H}{4} + \frac{(V + \rho(a^*) - \delta a^*)(2\theta_L + V + \rho(a^*) - \delta a^*)}{4\theta_L} - 2K$$

Looking at first order conditions we get:

$$\frac{\partial \pi_{MP}}{\partial \theta_H} = \frac{1}{4} > 0 \quad (2.2.23)$$

$$\frac{\partial \pi_{MP}}{\partial \theta_L} = -\frac{1}{4\theta_L^2} (V + \rho(a^*) - \delta a^*)^2 < 0 \quad (2.2.24)$$

Hence we get a result of maximal differentiation, as stated in the following Proposition

Proposition 9. *Given a technological constraint $\Theta = [\underline{\theta}, \bar{\theta}]$, when viewers differ in their willingness to pay for quality, the multi-channel broadcaster chooses to maximally differentiate quality: it chooses the minimal quality for the L channel while it sets the highest quality for the H one.*

$$\begin{aligned}
\theta_H^* &= \bar{\theta} \\
\theta_L^* &= \underline{\theta}
\end{aligned}$$

Moreover, it charges different subscription fees for the two channels, according to the quality level:

$$s_H^*(\bar{\theta}) > s_L^*(\underline{\theta})$$

According to Proposition 9, profits become:

$$\pi_{MP}^* = \frac{\bar{\theta}}{4} + \frac{(V - \delta a^* + \rho(a^*))(2\underline{\theta} + V - \delta a^* + \rho(a^*))}{4\underline{\theta}} - 2K \quad (2.2.25)$$

In the uniform case, equilibrium values for advertising, subscription fees, audience and profits are respectively:

$$\begin{aligned}
a_H^* &= a_L^* = a^* = \frac{1-\delta}{2} \\
s_H^* &= \frac{\bar{\theta} + V - \frac{(1-\delta)(1+3\delta)}{4}}{2} \\
s_L^* &= \frac{\underline{\theta} + V - \frac{(1-\delta)(1+3\delta)}{4}}{2}
\end{aligned}$$

¹³The result of this stage follows the assumption of fixed cost of quality, K . However, we obtain similar outcomes different functional form for the cost of quality (see Appendix 2.6.1).

$$\begin{aligned}
B_H^* &= \frac{1}{2} \\
B_L^* &= \frac{1}{2} - \frac{\underline{\theta} - V - (\frac{1-\delta}{2})^2}{2\underline{\theta}} \\
\pi_{MP}^* &= \frac{\bar{\theta}}{4} + \frac{(V + (\frac{1-\delta}{2})^2)(2\underline{\theta} + V + (\frac{1-\delta}{2})^2)}{4\underline{\theta}} - 2K
\end{aligned}$$

2.2.3 Viewers' Surplus

We turn now to the welfare implications. Let us start by considering the general formulation of the viewers' surplus:

$$SC_{MP} = \int_0^{\beta_{0L}} (u_0) d\beta + \int_{\beta_{0L}}^{\beta_{LH}} (u_L) d\beta + \int_{\beta_{LH}}^1 (u_H) d\beta \quad (2.2.26)$$

$$= \frac{1}{2}\beta_{LH}^2\theta_L + \beta_{LH}(V - \delta a_L - s_L) - \frac{1}{2}\beta_{0L}^2\theta_L - \beta_{0L}(V - \delta a_L - s_L) \quad (2.2.27)$$

$$+ \frac{1}{2}(1 - \beta_{LH}^2)\theta_H + (1 - \beta_{LH})(V - s_H - \delta a_H) \quad (2.2.28)$$

By substituting equilibrium values, we get

$$SC_{MP}^* = \frac{\bar{\theta}}{8} + \frac{(2\underline{\theta} + V + \rho(a^*) - \delta a^*)(V + \rho(a^*) - \delta a^*)}{8\underline{\theta}} \quad (2.2.29)$$

In the uniform case, provided that $a^* = (\frac{1-\delta}{2})$, equation (2.2.29) rewrites as follows:

$$SC_{MP} = \frac{\bar{\theta}}{8} + \frac{(2\underline{\theta} + V + (\frac{1-\delta}{2})^2)(V + (\frac{1-\delta}{2})^2)}{8\underline{\theta}}$$

which helps in assessing the effects of the nuisance parameter δ and the technological range $\Theta = (\underline{\theta}, \bar{\theta})$. The disutility parameter affects the consumers' surplus in two ways. First, an increase in δ has a direct negative impact on the individual utility, for a given advertising intensity. Second, there is an indirect impact through advertising. Indeed, in equilibrium, an increase in δ reduces advertising intensity. In turn, the effect of a lower advertising is twofold; the advertising cost per viewer $a^*\delta$ drops back and advertising revenues per viewers $\rho(a^*)$ are reduced. This latter effect induces a higher subscription fees due to profit-neutrality. The direct effect and the indirect one on subscription fees prevail inducing a negative impact on surplus:

$$\frac{\partial SC_{MP}^*}{\partial \delta} = \frac{1}{32\underline{\theta}} (\delta - 1) (\delta^2 - 2\delta + 4\underline{\theta} + 4V + 1) \leq 0$$

For $\delta < 1$ the above effect is strictly negative, while for $\delta > 1$ the effect is null due to the fact that the platform does not broadcast advertising in any channel.

$$\frac{\partial SC_{MP}^*}{\partial \bar{\theta}} = \frac{1}{8} > 0$$

$$\frac{\partial SC_{MP}^*}{\partial \underline{\theta}} = -\frac{1}{128\underline{\theta}^2} (\delta^2 - 2\delta + 4V + 1)^2 < 0$$

The above derivatives explain the positive effect of enlarging the technological range. Consumers benefit by widening differentiation between the two channels.

2.3 Multi-Channel vs Single-Channel Broadcaster

In order to assess the welfare analysis it should be relevant to compare our previous insights with case of a single-channel monopoly broadcaster. The equilibrium solution for the single-channel monopoly is along the line of the previous subsections. As the structure of the analysis does not vary, the mathematical analysis of this case can be found in the Appendix 2.6.2.¹⁴ The results provide an equal ground for comparing the multi-channel case to the single-channel case. The results for the single-channel case are summarized in the following Proposition:

Proposition 10. *A single-channel monopoly platform which maximizes profit in an uncovered market, shows the following equilibrium levels of advertising, subscription fee and audience share:*

$$a_M^* = \frac{1 - \delta}{2}$$

$$s_M^* = \frac{V + \theta_M^* - \rho(a_M^*) - \delta a_M^*}{2}$$

$$B_M^* = \frac{V + \theta_M^* + \rho(a^*) - \delta a^*}{2\theta_M^*}$$

Moreover, regarding quality, two possible equilibrium configurations emerge, depending on the technological range

$$\theta_M^* = \bar{\theta} \text{ if } \Theta_{RL} = [\underline{\theta}, \bar{\theta}] \text{ with } \underline{\theta} = \rho(a) - \delta a$$

$$\theta_M^* = \underline{\theta} \text{ if } \Theta_{RH} = [\underline{\theta}, \bar{\theta}] \text{ with } \underline{\theta} > 0 \text{ and } \bar{\theta} = \rho(a) - \delta a$$

Proof. See Appendix 2.6.2 □

We proceed by comparing viewers' surplus, subscription fees and audience shares in the multi-channel case and the single one.

Proposition 11. *In the multi-channel monopoly case, viewers' surplus is larger than in the single-channel case, independently of the technological range of quality.*

Proof. We consider first the case of $\Theta_{RL} = [\underline{\theta}, \bar{\theta}]$ with $\underline{\theta} = \rho(a) - \delta a$. We compare the multi-channel platform with the single-channel platform that provides the maximum quality. Viewers' surplus are respectively:

$$SC_{MP}^*(\underline{\theta}, \bar{\theta}) = \frac{\bar{\theta}}{8} + \frac{(2\underline{\theta} + V - \delta a^* + \rho(a^*))(V - \delta a^* + \rho(a^*))}{8\underline{\theta}}$$

$$SC_M^*(\bar{\theta}) = \frac{1}{8\bar{\theta}} (V + \rho(a^*) - \delta a^* + \bar{\theta})^2$$

If $\bar{\theta} > \underline{\theta}$

$$SC_{MP}^*(\underline{\theta}, \bar{\theta}) - SC_M^*(\bar{\theta}) = \frac{(\bar{\theta} - \underline{\theta})(V - \delta a^* + \rho(a^*))^2}{8\bar{\theta}\underline{\theta}} > 0$$

Analogously, in the case $\Theta_{RH} = [\underline{\theta}, \bar{\theta}]$ with $\underline{\theta} > 0$ and $\bar{\theta} = \rho(a) - \delta a$, we obtain the same result:

$$SC_{MP}^*(\underline{\theta}, \bar{\theta}) - SC_M^*(\underline{\theta}) = \frac{\bar{\theta} - \underline{\theta}}{8} > 0$$

□

¹⁴The results for the single-channel case rely on our previous paper Battagion and Drufuca (2014).

According to Proposition 11, the multi-channel monopoly is welfare improving, for what concerns viewers, with respect to the single-channel one, independently of the technological range of quality, i.e. independently of $\bar{\theta}$ and $\underline{\theta}$. At a first glance it seems that viewers benefit from the presence of multiple channels of different quality. In order to figure out the driving forces of this result, we compare equilibrium audiences and subscription fees. We make this comparison for two cases, either the single-channel monopoly choosing $\bar{\theta}$ or the single-channel monopoly choosing $\underline{\theta}$.

Table 2.3.1: COMPARISON AMONG REGIMES

	Case Θ_{RL}	Case Θ_{RH}
Viewers' Surplus	$SC_{MP}^* > SC_M^*$	$SC_{MP}^* > SC_M^*$
Channels' Quality Levels	$\theta_H^* = \theta_M^*$ $\theta_L^* < \theta_M^*$	$\theta_H^* > \theta_M^*$ $\theta_L^* = \theta_M^*$
Viewers' Fees	$s_M^* = s_H^*$ $s_M^* > s_L^*$	$s_M^* < s_H^*$ $s_M^* = s_L^*$
Viewers' Market Shares	$B_{MP}^*(\underline{\theta}, \bar{\theta}) > B_M^*(\bar{\theta})$	$B_{MP}^*(\underline{\theta}, \bar{\theta}) = B_M^*(\underline{\theta})$
Advertisers' Market Shares	$a_H^* = a_L^* = a_M^*$	$a_H^* = a_L^* = a_M^*$

Note: In this table, we compare equilibrium values of the multichannel monopoly broadcaster and the single-channel one. The case with the single-channel choosing maximum quality (Case Θ_{RL}) is shown in the first column, the case with minimum quality (Case Θ_{RH}) in the second column.

In the first case we disentangle two effects: one on subscription fees and the other on audience's share.¹⁵ The multi-channel broadcaster serves a larger market share of viewers with respect to the single-channel monopoly. Moreover it charges a lower price on the low quality channel. Hence, in this case, the welfare improving effect is driven by prices and market shares.

Similarly, we compare subscription fees and the audience's share for the second case: we can state that viewers benefit from the possibility of a multi-channel choice with a high quality option. Whereas, there is no positive effect on fees and share. Again, to highlight our findings, we illustrate our results in the case of a uniform distribution of advertisers, as summarized in the following Remark:

Remark 3. We consider the case of a uniform distribution of advertisers. We show that viewers' surplus is higher if they are served by a multi-channel monopoly compared to a single-channel one. This result holds independently of the technological range of quality; that is, either if the single-channel chooses the minimum quality (Θ_{RL}) or it chooses the maximum quality (Θ_{RH}). For what concern prices and audience's shares, we obtain the following equilibrium values (see Table 2.3.2), which confirm our previous insights on the different effects driving our results on surplus.

¹⁵Provided that $V + \rho(a^*) - \delta a^* > 0$.

Table 2.3.2: EQUILIBRIUM VALUES (Uniform Case)

	Case Θ_{RL}	Case Θ_{RH}
Channels' Quality Levels	$\theta_H^* = \bar{\theta}$ $\theta_L^* = \underline{\theta} = \frac{(1-\delta)^2}{4}$ $\theta_M^* = \bar{\theta}$	$\theta_H^* = \bar{\theta} = \frac{(1-\delta)^2}{4}$ $\theta_L^* = \underline{\theta}$ $\theta_M^* = \underline{\theta}$
Viewers' Fees	$s_H^* = \frac{\bar{\theta} + V - \frac{(1-\delta)(1+3\delta)}{4}}{2}$ $s_L^* = \frac{\underline{\theta} + V - \frac{(1-\delta)(1+3\delta)}{4}}{2}$ $s_M^* = \frac{V + \bar{\theta} - \frac{(1-\delta)(1+3\delta)}{4}}{2}$	$s_H^* = \frac{\bar{\theta} + V - \frac{(1-\delta)(1+3\delta)}{4}}{2}$ $s_L^* = \frac{\underline{\theta} + V - \frac{(1-\delta)(1+3\delta)}{4}}{2}$ $s_M^* = \frac{V + \underline{\theta} - \frac{(1-\delta)(1+3\delta)}{4}}{2}$
Viewers' Market Shares	$B_{MP}^*(\underline{\theta}, \bar{\theta}) = \frac{V + \underline{\theta} + \frac{(1-\delta)^2}{4}}{2\underline{\theta}}$ $B_M^*(\bar{\theta}) = \frac{V + \bar{\theta} + \frac{(1-\delta)^2}{4}}{2\bar{\theta}}$	$B_{MP}^*(\underline{\theta}, \bar{\theta}) = \frac{V + \underline{\theta} + \frac{(1-\delta)^2}{4}}{2\underline{\theta}}$ $B_M^*(\underline{\theta}) = \frac{V + \underline{\theta} + \frac{(1-\delta)^2}{4}}{2\underline{\theta}}$
Advertisers' Market Shares	$a_H^* = a_L^* = a_M^* = \frac{1-\delta}{2}$	$a_H^* = a_L^* = a_M^* = \frac{1-\delta}{2}$

Proof. For what concerns consumers' surplus, if $\Theta_{RL} = [\underline{\theta}, \bar{\theta}]$ with $\underline{\theta} = \rho(a - \delta a)$, then:

$$SC_{MP}^*(\underline{\theta}, \bar{\theta}) = \frac{\bar{\theta}}{8} + \frac{(2\underline{\theta} + V + (\frac{1-\delta}{2})^2)(V + (\frac{1-\delta}{2})^2)}{8\underline{\theta}}$$

$$SC_M^*(\bar{\theta}) = \frac{1}{8\bar{\theta}} \left(V + (\frac{1-\delta}{2})^2 + \bar{\theta} \right)^2$$

Then if $\bar{\theta} > \underline{\theta}$:

$$SC_{MP}^*(\underline{\theta}, \bar{\theta}) - SC_M^*(\bar{\theta}) = \frac{(\bar{\theta} - \underline{\theta})(V + (\frac{1-\delta}{2})^2)^2}{8\bar{\theta}\underline{\theta}} > 0$$

If $\Theta_{RH} = [\underline{\theta}, \bar{\theta}]$ with $\underline{\theta} > 0$ and $\bar{\theta} = \rho(a - \delta a)$:

$$SC_{MP}^*(\underline{\theta}, \bar{\theta}) = \frac{\bar{\theta}}{8} + \frac{(2\underline{\theta} + V + (\frac{1-\delta}{2})^2)(V + (\frac{1-\delta}{2})^2)}{8\underline{\theta}}$$

$$SC_M^*(\underline{\theta}) = \frac{1}{8\underline{\theta}} \left(V + (\frac{1-\delta}{2})^2 + \underline{\theta} \right)^2$$

Then if $\bar{\theta} > \underline{\theta}$:

$$SC_{MP}^*(\underline{\theta}, \bar{\theta}) - SC_M^*(\underline{\theta}) = \frac{\bar{\theta} - \underline{\theta}}{8} > 0$$

□

In the comparison between the single and the multi-channel monopoly broadcasters, we show that consumers obtain an higher surplus in the second case. Our results show that the chance of choosing among channels of different qualities is always beneficial for the viewers.

2.4 Competition among Single-Channel Broadcasters

In this section we modify our set up by considering competition among broadcasters. We present the case of a duopoly market where two single-channel platforms compete on viewers and advertisers. Without loss of generality we assume that one broadcaster provides the low quality channel, while the other the high quality one, setting $i = L, H$.¹⁶ For the remaining we maintain the same assumptions as in multi-channel set up.

Notice that, differently from the ongoing literature on vertically differentiated media, we consider an ex-ante uncovered market. This framework further complicates the model from an analytical point of view, arising multiple equilibria. To overcome this issue, we restrict the analysis to a local equilibrium: we identify a technological range of qualities allowing a local equilibrium of maximal differentiation to exist. We strongly believe it is worth to maintain an uncovered set-up since it better point out the effects of competition and since it well fits the features of broadcasting market.

2.4.1 Viewers' and Advertisers' Shares

We identify two marginal consumers: the one indifferent between not accessing to any platform and accessing the low quality platform

$$\beta_{0L} = \frac{s_L + \delta a_L - V}{\theta_L} \quad (2.4.1)$$

and the one indifferent between the low quality platform and the high quality one

$$\beta_{LH} = \frac{(s_H - s_L) + \delta(a_H - a_L)}{\theta_H - \theta_L} \quad (2.4.2)$$

Given our distribution of the willingness to pay for quality β , the trivial case in which the low-quality platform always faces zero demand in the price game is automatically ruled out. Hence, we consider an ex-ante market structure where both firms are active (meaning that the individuals' demands for both platforms H and L are positive).

We do not impose any further condition on the configuration: namely, we consider an ex-ante uncovered duopoly structure.

Hence, the high quality platform's share on viewers side is

$$B_H = (1 - \beta_{LH}) = \left(1 - \frac{(s_H - s_L) + \delta(a_H - a_L)}{\theta_H - \theta_L}\right) \quad (2.4.3)$$

whereas the low quality platform's share is

$$B_L = (\beta_{LH} - \beta_{0L}) = \left(\frac{(s_H - s_L) + \delta(a_H - a_L)}{\theta_H - \theta_L} - \frac{s_L + \delta a_L - V}{\theta_L}\right) \quad (2.4.4)$$

The intensities of advertising for the two platforms are respectively:

$$a_H = 1 - F\left(\frac{r_H}{B_H}\right) \quad (2.4.5)$$

$$a_L = 1 - F\left(\frac{r_L}{B_L}\right) \quad (2.4.6)$$

Having defined the shares of viewers and of advertisers, for given prices, we solve the game backwards, from stage three, as previously described for the monopoly. Therefore we obtain:

¹⁶We relax this ex-ante assumption when we look at the choice of quality (stage 1).

$$r_H(s_H, s_L, a_H, a_L, \theta_H, \theta_L) = F^{-1}(1 - a_H) \left(\frac{\theta_H - \theta_L - (s_H - s_L) - \delta(a_H - a_L)}{\theta_H - \theta_L} \right) \quad (2.4.7)$$

$$r_L(s_H, s_L, a_H, a_L, \theta_H, \theta_L) = F^{-1}(1 - a_L) \left(\frac{(s_H - s_L) + \delta(a_H - a_L)}{\theta_H - \theta_L} - \frac{s_L + \delta a_L - V}{\theta_L} \right) \quad (2.4.8)$$

2.4.2 Subscription Fees and Advertising Intensities

According to the previous assumptions, each platform maximizes profits subject to a positivity constraint on advertising:

$$\begin{cases} \max_{a_i, s_i} \Pi_i = B_i(s_i + \rho_i) - K \\ s.t. a_i \geq 0 \end{cases}$$

for $i = H, L$.

Proposition 12. *For each platform $i = H, L$, if the profit maximizing advertising level is positive, then it is constant and it is determined by*

$$\rho'(a_i) = \delta$$

Proof. We consider first the maximization problem of the L platform. Under the assumption that $\frac{\partial B_L}{\partial a_L} = \delta \frac{\partial B_L}{\partial s_L}$ and $\frac{\partial B_H}{\partial a_L} = \delta \frac{\partial B_H}{\partial s_L}$, first order conditions are:

$$\frac{\partial \pi_L}{\partial s_L} = \frac{\partial B_L}{\partial s_L}(s_L + \rho(a_L)) + B_L = 0 \quad (2.4.9)$$

$$\frac{\partial \pi_L}{\partial a_L} = \delta \frac{\partial B_L}{\partial s_L}(s_L + \rho(a_L)) + B_L(\rho'(a_L)) \leq 0 \quad (2.4.10)$$

If $a_L > 0$, optimality conditions rewrite as follows

$$\begin{aligned} \frac{\partial B_L}{\partial s_L}(s_L + \rho(a_L)) &= -B_L \\ \delta \frac{\partial B_L}{\partial s_L}(s_L + \rho(a_L)) + B_L(\rho'(a_L)) &= 0 \end{aligned}$$

Hence, by substitution we get

$$\rho'(a_L) = \delta \quad (2.4.11)$$

The same applies to the high quality platform, giving us:

$$\rho'(a_H) = \delta \quad (2.4.12)$$

□

Proposition 12 states that, for both platforms, a fixed advertising space is the best reply. In particular, the equilibrium intensity of advertising depends just on the nuisance parameter δ . If aversion to ads is "too high", then is optimal to set advertising equal to zero. Hence, the optimal advertising intensity considers just the negative externality of advertisers on viewers, suggesting that both platform just compete on individuals. Indeed, platforms act as "bottlenecks" between advertisers and individuals, by offering sole access to their respective set of individuals.

Moreover, by considering the case of a uniform distribution of advertisers, we point out that:

Remark 4. We consider the case of a uniform distribution of advertisers. The strategic choices of advertising intensity of the two platform are the same and depend just on the nuisance parameter δ :

$$a_i^* = \frac{1 - \delta}{2} \text{ for } i = H, L$$

if $\delta < 1$. Otherwise, is zero.

We can now compute the subscription fees, the advertising prices and the audience shares of the two platforms.

Proposition 13. *Platform H and platform L set the following equilibrium values for subscription fees, audience shares and advertising prices:*

$$\begin{aligned} s_H^* &= \frac{(V - a^*\delta + 2\theta_H)(\theta_H - \theta_L) - 3\rho(a^*)\theta_H}{4\theta_H - \theta_L} \\ s_L^* &= \frac{(2(V - a^*\delta) + \theta_L)(\theta_H - \theta_L) - 2\rho(a^*)\theta_H - \rho(a^*)\theta_L}{4\theta_H - \theta_L} \\ B_H^* &= \frac{2\theta_H + V + \rho(a^*) - a^*\delta}{4\theta_H - \theta_L} \\ B_L^* &= \frac{2\theta_H \frac{1}{2}\theta_L + V + \rho(a^*) - a^*\delta}{\theta_L (4\theta_H - \theta_L)} \\ r_H^* &= \frac{\rho(a^*)}{a^*(4\theta_H - \theta_L)}(V + 2\theta_H + \rho(a^*) - a^*\delta) \\ r_L^* &= \frac{2\rho(a^*)}{a^*(4\theta_H - \theta_L)}(V + \frac{1}{2}\theta_L + \rho(a^*) - a^*\delta) \end{aligned}$$

Proof. Given the results of Proposition 12, we compute equilibrium subscription fees for the two platforms from the second FOCs

$$\begin{aligned} \frac{\partial B_H}{\partial s_H}(s_H + \rho(a_H)) + B_H = \\ (-\frac{1}{\theta_H - \theta_L})(s_H + \rho(a_H)) + \left(1 - \frac{(s_H - s_L) + \delta(a_H - a_L)}{\theta_H - \theta_L}\right) = 0 \end{aligned} \quad (2.4.13)$$

$$\begin{aligned} \frac{\partial B_L}{\partial s_L}(s_L + \rho(a_L)) + B_L = \\ (-\frac{1}{\theta_H - \theta_L} - \frac{1}{\theta_L})(s_L + \rho(a_L)) + \left(\frac{(s_H - s_L) + \delta(a_H - a_L)}{\theta_H - \theta_L} - \frac{s_L + \delta a_L - V}{\theta_L}\right) = 0 \end{aligned} \quad (2.4.14)$$

Since at equilibrium the advertising intensity is the same, $a_i = a$ and $\rho(a_i) = \rho(a)$ for $i = H, L$:

$$s_H = \frac{\theta_H - \theta_L + s_L - \rho(a)}{2} \quad (2.4.15)$$

$$s_L = \frac{(V - a\delta)(\theta_H - \theta_L) - \rho(a)\theta_H + \theta_L s_H}{2\theta_H} \quad (2.4.16)$$

Then, if $\theta_H > \theta_L > 0$

$$s_H^* = \frac{(V - a^*\delta + 2\theta_H)(\theta_H - \theta_L) - 3\rho(a^*)\theta_H}{4\theta_H - \theta_L} \quad (2.4.17)$$

$$s_L^* = \frac{(2(V - a^*\delta) + \theta_L)(\theta_H - \theta_L) - 2\rho(a^*)\theta_H - \rho(a^*)\theta_L}{(4\theta_H - \theta_L)} \quad (2.4.18)$$

Shares become:

$$B_H^* = \frac{2\theta_H + V + \rho(a^*) - a^*\delta}{4\theta_H - \theta_L} \quad (2.4.19)$$

$$B_L^* = \frac{2\theta_H \frac{1}{2}\theta_L + V + \rho(a^*) - a^*\delta}{\theta_L (4\theta_H - \theta_L)} \quad (2.4.20)$$

□

Differently from the multi-channel monopoly case, all the equilibrium values for each channel depend upon both its own quality and the competitor's one. There is a strategic interdependence between the two broadcasters resulting in prices and shares depending on quality differentiation.

We consider the case of a uniform distribution of advertisers, to get a sharper intuition of our results. Equilibrium solutions of stage 2 rewrites as follows. Subscription fees:

$$s_H^* = \frac{(V + 2\theta_H)(\theta_H - \theta_L) - \frac{1}{4}(1 - \delta)(3\theta_H + \delta(5\theta_H - 2\theta_L))}{4\theta_H - \theta_L}$$

$$s_L^* = 2 \frac{(V + \frac{1}{2}\theta_L)(\theta_H - \theta_L) - \frac{1}{4}(1 - \delta)(\theta_H + \frac{1}{2}\theta_L + 3\delta(\theta_H - \frac{1}{2}\theta_L))}{(4\theta_H - \theta_L)}$$

Viewers' Shares:

$$B_H^* = \frac{2\theta_H + V + (\frac{1-\delta}{2})^2}{4\theta_H - \theta_L}$$

$$B_L^* = \frac{2\theta_H \frac{1}{2}\theta_L + V + (\frac{1-\delta}{2})^2}{\theta_L (4\theta_H - \theta_L)}$$

Advertising prices

$$r_H^* = \frac{(\frac{1+\delta}{2})}{(4\theta_H - \theta_L)} \left(V + 2\theta_H + (\frac{1-\delta}{2})^2 \right)$$

$$r_L^* = \frac{2(\frac{1+\delta}{2})}{(4\theta_H - \theta_L)} \left(V + \frac{1}{2}\theta_L + (\frac{1-\delta}{2})^2 \right)$$

2.4.3 Qualities

We can now solve the initial stage of the game, namely the quality choice.

At the first stage, platforms' profits are respectively for H and L :

$$\pi_H^* = \frac{(2\theta_H + V + \rho(a^*) - a^*\delta)^2 (\theta_H - \theta_L)}{(4\theta_H - \theta_L)^2} - K$$

$$\pi_L^* = \left(\frac{4\theta_H (\frac{1}{2}\theta_L + V + \rho(a^*) - a^*\delta)^2 (\theta_H - \theta_L)}{\theta_L (4\theta_H - \theta_L)^2} \right) - K$$

Then FOC with respect to quality are:

$$\frac{\partial \pi_H}{\partial \theta_H} = \frac{(2\theta_H + Z)[4(\theta_H - \theta_L) + 2\theta_H + Z](4\theta_H - \theta_L) - 8(2\theta_H + Z)^2(\theta_H - \theta_L)}{(4\theta_H - \theta_L)^3} = 0 \quad (2.4.21)$$

$$\frac{\partial \pi_L}{\partial \theta_L} = 4\theta_H \left(\frac{(\frac{1}{2}\theta_L + Z)(4\theta_H - \theta_L)(\theta_H - \theta_L)(\frac{1}{2}\theta_L - Z) - \theta_L (\frac{1}{2}\theta_L + Z)^2 (2\theta_H + \theta_L)}{(4\theta_H - \theta_L)^3 \theta_L^2} \right) = 0 \quad (2.4.22)$$

with $Z = V + \rho(a^*) - a^*\delta$

Conditions (2.4.21) and (2.4.22) implicitly define the best replies in quality for the two platforms. Unfortunately, the simultaneous solution does not give us a unique outcome. To make our duopoly comparable with the multi-channel case, we decide to focus on an equilibrium with maximal differentiation in quality. Therefore, we restrict the technological range of quality (Θ) to a narrower set $\Theta^d = (\underline{\theta}, \bar{\theta})$ with $\underline{\theta} > \frac{4}{7}\bar{\theta}$. For $\theta_H, \theta_L \in \Theta^d$, we obtain the following result:

Proposition 14. *In the restricted range of qualities $\Theta^d = (\underline{\theta}, \bar{\theta})$ with $\underline{\theta} > \frac{4}{7}\bar{\theta}$ there is a unique local equilibrium of maximal differentiation, where subscription fees and audience shares are:*

$$\begin{aligned} s_H^* &= \frac{(V - a^*\delta + 2\bar{\theta})(\bar{\theta} - \underline{\theta}) - 3\rho(a^*)\bar{\theta}}{4\bar{\theta} - \underline{\theta}} \\ s_L^* &= \frac{(2(V - a^*\delta) + \underline{\theta})(\bar{\theta} - \underline{\theta}) - 2\rho(a^*)\bar{\theta} - \rho(a^*)\underline{\theta}}{(4\bar{\theta} - \underline{\theta})} \\ B_H^* &= \frac{2\bar{\theta} + V + \rho(a^*) - a^*\delta}{4\bar{\theta} - \underline{\theta}} \\ B_L^* &= \frac{2\bar{\theta} \frac{1}{2}\underline{\theta} + V + \rho(a^*) - a^*\delta}{\underline{\theta} \quad 4\bar{\theta} - \underline{\theta}} \end{aligned}$$

Proof. If $4\theta_H < 7\theta_L$, then we show that:

$$\frac{\partial \pi_H}{\partial \theta_H} > 0 \tag{2.4.23}$$

$$\frac{\partial \pi_L}{\partial \theta_L} < 0 \tag{2.4.24}$$

Hence, for every $\theta \in \Theta^D = (\underline{\theta}, \bar{\theta})$ with $\underline{\theta} > \frac{4}{7}\bar{\theta}$, (2.4.23) and (2.4.24) hold. Therefore:

$$\begin{aligned} \theta_H^* &= \bar{\theta} \\ \theta_L^* &= \underline{\theta} \end{aligned}$$

□

Notice that, if the market were uncovered ex-ante, we would have obtained fixed audience shares.¹⁷ Instead, we show that the audience shares depend on the quality distance of the two platforms. Hence, we can use our results on audience shares to highlights the effects of our assumption of uncovered market.

Furthermore, in our analysis, the level of qualities are fixed at maximum differentiation. However, our setting also allows for modelling an endogenous decision on quality levels, though analytically hardly tractable. Nevertheless, our results in the local equilibrium may give a suggestion on how these quality levels would change if the decisions of quality were endogenous.

¹⁷See Weeds (2013).

2.4.4 Viewers' Surplus

We now address the welfare analysis from the point of view of the viewers. Viewers' surplus in the uncovered duopoly is:

$$SC_D(\underline{\theta}, \bar{\theta}) = \int_0^{\beta_{0L}} (u_0) d\beta + \int_{\beta_{0L}}^{\beta_{LH}} (u_L) d\beta + \int_{\beta_{LH}}^1 (u_H) d\beta \quad (2.4.25)$$

At the local equilibrium, we obtain:

$$SC_D^*(\underline{\theta}, \bar{\theta}) = \frac{1}{2} \frac{\bar{\theta}}{\underline{\theta} (4\bar{\theta} - \underline{\theta})^2} ((4\bar{\theta} + 5\underline{\theta}) (\bar{\theta}\underline{\theta} + Z^2) + 2\underline{\theta} (8\bar{\theta} + \underline{\theta}) Z) \quad (2.4.26)$$

with $Z = V + \rho(a^*) - a^*\delta$.

2.5 The Welfare Effects of Competition

Viewers' surplus is an important element to be considered when we analyze the effect of potential competition. In this perspective we first compare our duopoly with the multi-channel monopoly case described in the first section. In this comparison we pay particular attention to the difference between viewers' surpluses and we also consider how prices and audiences change according to the degree of competition.

Proposition 15. *If both the duopoly and the multi-channel monopoly configuration show a situation of maximum differentiation, viewers are better off with more competition (duopoly). That is:*

$$SC_D^*(\underline{\theta}, \bar{\theta}) - SC_{MP}^*(\underline{\theta}, \bar{\theta}) > 0$$

Proof. Recall equilibrium viewers' surplus in duopoly (ex-ante uncovered) with maximal differentiation (with $\Theta^d = (\underline{\theta}, \bar{\theta})$ such that $\underline{\theta} > \frac{4}{7}\bar{\theta}$) from equation (2.4.26)

$$SC_D^*(\underline{\theta}, \bar{\theta}) = \frac{1}{2} \frac{\bar{\theta}}{\underline{\theta} (4\bar{\theta} - \underline{\theta})^2} ((4\bar{\theta} + 5\underline{\theta}) (\bar{\theta}\underline{\theta} + Z^2) + 2\underline{\theta} (8\bar{\theta} + \underline{\theta}) Z)$$

with $Z = V + \rho(a^*) - a^*\delta$, and equilibrium viewers' surplus in the multichannel monopoly from equation (2.2.29)

$$SC_{MP}^*(\underline{\theta}, \bar{\theta}) = \frac{1}{8\underline{\theta}} (\underline{\theta}\bar{\theta} + (V + \rho(a^*) - a^*\delta)^2 + 2\underline{\theta}V + \rho(a^*) - a^*\delta)$$

If we compare them we get:

$$\begin{aligned} & SC_D^*(\underline{\theta}, \bar{\theta}) - SC_{MP}^*(\underline{\theta}, \bar{\theta}) \\ &= \frac{1}{8(\underline{\theta} - 4\bar{\theta})^2} \left((28\bar{\theta} - \underline{\theta}) (Z^2 + \bar{\theta}\underline{\theta}) + 2Z(16\bar{\theta}^2 - \underline{\theta}^2) + 24\bar{\theta}\underline{\theta}Z \right) \end{aligned}$$

with $Z = V + \rho(a^*) - a^*\delta$. The above expression is for sure positive, provided that $\rho(a^*) - a^*\delta > 0$. Notice that this is the case if we consider a uniform distribution of advertisers. Namely, in the uniform case we have $\rho(a^*) - a^*\delta = \left(\frac{1-\delta}{2}\right)^2 > 0$, which give us:

$$SC_D^*(\underline{\theta}, \bar{\theta}) - SC_{MP}^*(\underline{\theta}, \bar{\theta}) > 0$$

□

As shown in Table 2.5.1, this result is driven by lower prices in the duopoly case, provided that $\rho(a^*) - a^*\delta > 0$ (as in the uniform case). In addition, there is a better market coverage by the two competing firms, as emerges from the shares' comparison.¹⁸

Table 2.5.1: DUOPOLY vs MULTI-CHANNEL MONOPOLY

Viewers' Surplus	$SC_D^* > SC_{MP}^*$
Channels' Quality Levels	$\theta_H^{D*} = \theta_H^{MP*}$ $\theta_L^{D*} = \theta_L^{MP*}$
Viewers' Fees	$s_H^{*D} < s_H^{*MP}$ $s_H^{*D} < s_H^{*MP}$
Viewers' Market Shares	$B_H^{*D} > B_H^{MP}$ $B_L^{*D} > B_L^{MP}$
Advertisers' Market Shares	$a_i^{D*} = a_i^{MP*}$

Finally we make a last comparison between our duopoly (uncovered) and an ex-ante covered duopoly. If we consider the restricted range $\Theta^d = (\underline{\theta}, \bar{\theta})$ with $\underline{\theta} > \frac{4}{7}\bar{\theta}$, both configurations show maximal differentiation but different subscription fees and audience shares.

Proposition 16. *In the duopoly case, if both the ex-ante covered and the uncovered configuration lead to a situation of maximum differentiation, viewers are better off in the uncovered duopoly.*

Proof. If the market is ex-ante covered we just need one marginal individual β_{LH} . We compute viewers' surplus in the ex-ante covered case using equilibrium values:

$$\beta_{LHDcovered}^* = \frac{1}{3}$$

$$B_{HDcovered}^* = \frac{2}{3}$$

$$B_{LDcovered}^* = \frac{1}{3}$$

$$s_{HDcovered}^* = \frac{2}{3}(\bar{\theta} - \underline{\theta}) - \rho(a^*)$$

$$s_{LDcovered}^* = \frac{1}{3}(\bar{\theta} - \underline{\theta}) - \rho(a^*)$$

¹⁸We compare a duopoly of single-channel broadcasters with a multi-channel monopoly broadcaster. We concentrate on a local equilibrium where both market configurations exhibit maximal differentiation in quality. Hence, we must impose some restrictions on the technological range Θ , namely $\Theta^d = (\underline{\theta}, \bar{\theta})$ such that $\underline{\theta} > \frac{4}{7}\bar{\theta}$.

$$SC_{Dcovered}^*(\underline{\theta}, \bar{\theta}) = \frac{-2\bar{\theta} + 11\underline{\theta}}{18} + V + \rho(a^*) - a^*\delta \quad (2.5.1)$$

We compare this surplus with the one from equation (2.4.26), under the constraint $\Theta^d = (\underline{\theta}, \bar{\theta})$ with $\underline{\theta} > \frac{4}{7}\bar{\theta}$:

$$SC_D^*(\underline{\theta}, \bar{\theta}) - SC_{Dcovered}^*(\underline{\theta}, \bar{\theta}) > 0$$

provided that $\rho(a^*) - a^*\delta > 0$ (which is true in the uniform case).

Since we have considered the covered and the uncovered duopoly as two different market configurations, we have to check if this distinction still holds in equilibrium. In equilibrium, the duopoly broadcasting market is ex-post uncovered if: ¹⁹

$$\bar{\theta} - \underline{\theta} > \frac{\beta_{0L} > 0}{\underline{\theta}} \frac{2\bar{\theta} + \underline{\theta}}{\underline{\theta}} (V + \rho(a^*) - a^*\delta) \quad (2.5.2)$$

□

If this were the case, we can provide some more intuitions by looking at fees and audience shares. When quality differentiation is sufficiently high, the covered duopoly shows higher market shares but also higher subscription fees on both channels compared to the uncovered scenario. Higher prices explain the distance between covered and uncovered surpluses. Indeed, the possibility of catching extra viewers, as it happens in the uncovered market, disciplines the behavior of platform in duopoly making, consumers' surplus higher.

It is trivial to show that if:

$$\bar{\theta} - \underline{\theta} > \underbrace{\frac{3}{2}(V + \rho(a^*) - a^*\delta)}_A \quad (2.5.3)$$

then $B_{Hcovered}^* > B_H^*$ and $s_{icovered}^* > s_i^*$ for $i = H, L$.

Analogously if

$$\bar{\theta} - \underline{\theta} > \underbrace{6\frac{\bar{\theta}}{\underline{\theta}}(V + \rho(a^*) - a^*\delta)}_B \quad (2.5.4)$$

then $B_{Lcovered}^* > B_L^*$.

Recall from condition (2.5.2), that the market is uncovered (ex-post) if

$$\bar{\theta} - \underline{\theta} > \underbrace{\frac{2\bar{\theta} + \underline{\theta}}{\underline{\theta}}(V + \rho(a^*) - a^*\delta)}_C$$

It is possible to show that $A < C < B$. If $\bar{\theta} - \underline{\theta} > B$ then $s_{icovered}^* > s_i^*$ and $B_{icovered}^* > B_i^*$ for $i = H, L$. The covered duopoly has higher prices and audiences on both channels. If instead $C < \bar{\theta} - \underline{\theta} < B$ then $s_{icovered}^* > s_i^*$ and $B_{Hcovered}^* > B_H^*$ but $B_{Lcovered}^* < B_L^*$: prices are still higher but now the uncovered has a higher share on the low quality channel. Finally if $\bar{\theta} - \underline{\theta} < C$ the uncovered market becomes covered. However, as already mentioned, a comparison between two covered market structures is meaningless. Given that, when we considered a comparison between an uncovered ($\bar{\theta} - \underline{\theta} > C$) and a covered structure, it must be the case that the covered one privileges the high quality channels and sets higher subscription fees on both channels.

¹⁹Notice that the market is covered ex-post if condition (2.5.2) is not satisfied. However, we omit this case from our analysis, since a comparison between two covered market structures is meaningless.

2.6 Conclusions

In this paper we perform a welfare analysis in a setting of vertical differentiated two-sided broadcasters, where competition prevails on one side of the market, namely on viewers. A broadcaster acts as "bottleneck" between advertisers and viewers by offering sole access to its audience. We provide a full characterization of equilibria for what concerns advertising, subscription fees, market shares and qualities, for a monopoly with a single-channel platform, multi-channel monopoly and duopoly cases. For what concern the welfare analysis, we focus on the viewers side, calculating the consumers' surplus for each market structure.

It is important to stress that, differently from the ongoing literature on vertically differentiated media, we consider an ex-ante uncovered market for the duopoly case. This framework further complicates the model from an analytical point of view, arising multiple equilibria. To overcome this issue we identify a technological range of qualities allowing a local equilibrium of maximal differentiation to exist. Nevertheless, we strongly believe it is worth to maintain an uncovered set-up since to better point out the effects of competition on audience and prices.

Let us remark that equilibrium quality depends also on the cost structure used in this model. Under the assumption of fixed costs, monopoly profit function is convex in quality. One might expect that this shape strictly depends on the assumption of K , fixed cost of quality. As a matter of fact, in a single-side framework the standard model of vertical differentiation is solved with a quadratic cost of quality inducing concavity of profit function. However in a two-sided setting the issue of concavity of profit function is more complex. As expected, even in the two-sided approach, linear cost of quality does not solve the problem of convexity of profit function. But, more surprisingly, even increasing marginal cost of quality does not guarantee a well-shaped monopoly profit function. For instance, quadratic cost of quality (see Weeds (2013)) do not make concave the monopoly profit function, for what concerns quality, without *ad hoc* assumptions on the derivatives. One possible way out would be having implicit quality cost functions (see Anderson (2007)), that, however, should be unable to provide a close solution of the model. Therefore we chose to introduce the simplest cost function and a technological range bounding the levels of quality.

Our results show that the chance of choosing among channels of different qualities is always beneficial for the viewers. In the comparison between the single and the multi-channel monopoly broadcasters, this result is mainly driven by two forces. On the one hand, the possibility of choosing among different qualities and, on the other, a larger audience coverage and a pricing effect.

We also prove that competition is beneficial for the audience. The audience surplus is larger in the duopoly configuration than in the monopoly setting, when both provide high and low-quality channels. Indeed, on both channels, subscription fees are lower while the shares of viewer are larger. This result suggests that the ownership in broadcasting markets matters. In this respect our model supports the existing regulation practice of setting limits on the ownership of TV channels in order to induce a more fragmented market structure.

Finally, we highlight the comparison between the covered and the uncovered duopoly. In case of an uncovered market, the chance of catching extra viewers disciplines the platforms' behavior in duopoly making consumers' surplus higher. From the policy makers point of view, this result is crucial in the broadcasting sector, where the convergence between television and internet continuously opens up new market segments.

Bibliography

- [1] Anderson, Simon P. (2007) "Regulation of television advertising" In: Seabright, Paul and Von Hagen, Jurgen (eds), *The economic regulation of broadcasting markets*, Cambridge University Press, London
- [2] Anderson, Simon P. and Coate, Stephen (2005) "Market Provision of Broadcasting: a Welfare Analysis", *Review of Economic Studies*, 72: 947-972.
- [3] Areeda, Herbert and Hovenkamp, Phillip E. (2014) *Antitrust Law: An Analysis of Antitrust Principles and their Application*, Aspen Publishers, 4th ed.
- [4] Armstrong, Mark (2006) "Competition in two-sided markets", *Rand Journal of Economics*, 37, 3: 668-691.
- [5] Battaglion, Maria Rosa and Drufuca, Serena M. (2014) "Quality Competition among Platforms: a Media Market Case", Working paper n. 3/2014, University of Bergamo.
- [6] Born, Georgina and Prosser, Tony (2001) "Culture and Consumerism: Citizenship, Public Service Broadcasting and the BBC's Fair Trading Obligations", *Modern Law Review*, 64 (5): 657-687.
- [7] Collins, Richard (2007) "The BBC and public value." *Medien und Kommunikationswissenschaft*, 65(2): 164-184.
- [8] Dukes, Anthony (2004) "The Advertising Market in a Product Oligopoly", *Journal of Industrial Economics*, 52 (3): 327-348.
- [9] Ellman, Mattew (2014) "How to subsidise the news", mimeo.
- [10] González-Maestre, Miguel and Martínez-Sánchez, Francisco (2013) "The role of platform quality and publicly owned platforms in the free-to-air broadcasting industry", *SERIEs*, vol. 5, 1:105-124.
- [11] Kind, Hans Jarle and Nilssen, Tore and Sørgard, Lars (2009) "Business Models for Media Firms: Does Competition Matter for How They Raise Revenue", *Marketing Science*, 28, 6: 1112-1128.
- [12] Lin, Panlang (2011) "Market Provision of Program Quality in the Television Broadcasting Industry", *The B.E. Journal of Economic Analysis & Policy*, 11,1: 1-20.
- [13] Mephram, John (1990) "The question of quality" In: *The ethics of quality in television*, British Film Institute, pages 56-72.
- [14] Peitz, Martin and Valletti, Tommaso (2008) "Content and advertising in the media: pay-tv versus free-to-air", *International Journal of Industrial Organization*, 4: 949-965.
- [15] Roger, Guillaume (2010) Two-sided competition and differentiation (with an application to media). Discussion Papers 2010-27. School of Economics, The University of New South Wales.

- [16] Rowat, Colin (2007) "Technological and regulatory developments in broadcasting : an overview" in P. Seabright and J. von Hagen (eds.), *The economic regulation of broadcasting markets : evolving technology and the challenges for policy*, Cambridge University Press, London: 11-44.
- [17] Shapiro, Carl and Varian, Hal R. (1998) *Information Rules: A strategic Guide to the Network Economy*, Harvard Business Press.
- [18] Weeds, Helen (2013) "Programme Quality in Subscription and Advertising-Funded Television", *mimeo*

Appendix

2.6.1 Multi-product Monopoly with Different Costs of Quality (Quality Stage)

Linear Costs ²⁰

Profits at stage 1 are:

$$\pi_{MP} = \frac{\theta_H}{4} + \frac{(V + \rho(a^*) - \delta a^*)(2\theta_L + V + \rho(a^*) - \delta a^*)}{4\theta_L} - \gamma\theta_H - \gamma\theta_L \quad (2.6.1)$$

Looking at first order conditions we get:

$$\frac{\partial \pi_{MP}}{\partial \theta_H} = \frac{1}{4} - \gamma = 0 \quad (2.6.2)$$

$$\frac{\partial \pi_{MP}}{\partial \theta_L} = -\frac{1}{4\theta_L^2} (V + \rho(a^*) - \delta a^*)^2 - \gamma < 0 \quad (2.6.3)$$

Optimal qualities are:

$$\theta_H^* = \bar{\theta} \text{ if } \gamma < \frac{1}{4} \quad (2.6.4)$$

$$\theta_H^* = \underline{\theta} \text{ if } \gamma > \frac{1}{4} \quad (2.6.5)$$

$$\theta_L^* = \underline{\theta} \quad (2.6.6)$$

The degree of differentiation depends on the cost parameter γ .

- If $\gamma < \frac{1}{4}$ the platform chooses to maximally differentiate the two channels.
- If $\gamma > \frac{1}{4}$ the platform chooses to duplicate the minimum quality

In the first case profits become:

$$\pi_{MP}^* = \frac{\bar{\theta}}{4} + \frac{(V - \delta a^* + \rho(a^*))(2\underline{\theta} + V - \delta a^* + \rho(a^*))}{4\underline{\theta}} - \gamma(\bar{\theta} + \underline{\theta}) \quad (2.6.7)$$

In the uniform case equilibrium values are:

$$a_H^* = a_L^* = a^* = \frac{1 - \delta}{2} \quad (2.6.8)$$

²⁰Both linear and quadratic costs are assumed to be separable. See Section 2.2.

$$s_H^* = \frac{\bar{\theta} + V - \frac{(1-\delta)(1+3\delta)}{4}}{2} \quad (2.6.9)$$

$$s_L^* = \frac{\underline{\theta} + V - \frac{(1-\delta)(1+3\delta)}{4}}{2} \quad (2.6.10)$$

$$B_H^* = \frac{1}{2} \quad (2.6.11)$$

$$B_L^* = \frac{1}{2} - \frac{\underline{\theta} - V - \left(\frac{1-\delta}{2}\right)^2}{2\underline{\theta}} \quad (2.6.12)$$

$$\pi_{MP}^* = \frac{\bar{\theta}}{4} + \frac{(V + \left(\frac{1-\delta}{2}\right)^2)(2\underline{\theta} + V + \left(\frac{1-\delta}{2}\right)^2)}{4\underline{\theta}} - \gamma(\bar{\theta} + \underline{\theta}) \quad (2.6.13)$$

Quadratic Costs

Profits at stage 1 are:

$$\pi_{MP} = \frac{\theta_H}{4} + \frac{(V + \rho(a^*) - \delta a^*)(2\theta_L + V + \rho(a^*) - \delta a^*)}{4\theta_L} - \frac{1}{2}\gamma\theta_H^2 - \frac{1}{2}\gamma\theta_L^2 \quad (2.6.14)$$

Looking at first order conditions we get:

$$\frac{\partial \pi_{MP}}{\partial \theta_H} = \frac{1}{4} - \gamma\theta_H = 0 \quad (2.6.15)$$

$$\frac{\partial \pi_{MP}}{\partial \theta_L} = -\frac{1}{4\theta_L^2} (V + \rho(a^*) - \delta a^*)^2 - \gamma\theta_L < 0 \quad (2.6.16)$$

Optimal qualities are:

$$\theta_H^* = \frac{1}{4\gamma} \quad (2.6.17)$$

$$\theta_L^* = \underline{\theta} \quad (2.6.18)$$

The degree of differentiation depends on the dimension of the technological constraint with respect to the cost parameter γ .

- If $\underline{\theta} < \frac{1}{4\gamma}$ the platform chooses a quality above the minimum.
- If $\underline{\theta} < \frac{1}{4\gamma} < \bar{\theta}$ the platform chooses a quality above the minimum but below the maximum.
- If $\bar{\theta} < \frac{1}{4\gamma}$ the platform chooses to reach the upper bound of the range $\bar{\theta}$.

Hence, with $\underline{\theta} < \bar{\theta} < \frac{1}{4\gamma}$, we get a result of maximal differentiation and profits become:

$$\pi_{MP}^* = \frac{\bar{\theta}}{4} + \frac{(V - \delta a^* + \rho(a^*))(2\underline{\theta} + V - \delta a^* + \rho(a^*))}{4\underline{\theta}} - \frac{1}{2}\gamma(\bar{\theta}^2 + \underline{\theta}^2) \quad (2.6.19)$$

In the uniform case equilibrium values are:

$$a_H^* = a_L^* = a^* = \frac{1 - \delta}{2} \quad (2.6.20)$$

$$s_H^* = \frac{\bar{\theta} + V - \frac{(1-\delta)(1+3\delta)}{4}}{2} \quad (2.6.21)$$

$$s_L^* = \frac{\underline{\theta} + V - \frac{(1-\delta)(1+3\delta)}{4}}{2} \quad (2.6.22)$$

$$B_H^* = \frac{1}{2} \quad (2.6.23)$$

$$B_L^* = \frac{1}{2} - \frac{\underline{\theta} - V - \left(\frac{1-\delta}{2}\right)^2}{2\underline{\theta}} \quad (2.6.24)$$

$$\pi_{MP}^* = \frac{\bar{\theta}}{4} + \frac{(V + \left(\frac{1-\delta}{2}\right)^2)(2\underline{\theta} + V + \left(\frac{1-\delta}{2}\right)^2)}{4\underline{\theta}} - \frac{1}{2}\gamma(\bar{\theta}^2 + \underline{\theta}^2) \quad (2.6.25)$$

2.6.2 Monopoly (Single-Product)

Monopoly (Single Product): Viewers' and Advertisers' Shares

By considering the individual indifferent between accessing the monopoly platform or not accessing at all, we obtain the demand function by viewers.²¹

$$\beta_{0M} = \frac{s_M + \delta a_M - V}{\theta_M} \quad (2.6.26)$$

Since individuals are uniformly distributed between 0 and 1, the demand for the monopoly platform is simply given by the fraction of population with a taste for quality greater than β_{0M} :

$$B_M = (1 - \beta_{0M}) = \left(\frac{V + \theta_M - s_M - \delta a_M}{\theta_M} \right) \quad (2.6.27)$$

The amount of advertising for the platform becomes:

$$a_M = 1 - F\left(\frac{r_M}{B_M}\right) \quad (2.6.28)$$

Having defined the demand function of viewers and advertisers, for given prices r_M and s_M , we solve the game backwards, from stage three. Therefore by simultaneously solving the equations (2.6.27) and (2.6.28) we get:

$$r_M(s_M, a_M, \theta_M) = F^{-1}(1 - a_M) \left(\frac{V + \theta_M - s_M - \delta a_M}{\theta_M} \right) \quad (2.6.29)$$

This equation describes how the advertising charge reacts to changes in subscribers' price, advertising and quality.

²¹This section summarizes the results for a single-channel monopoly case and it builds on the model of Battaglion and Drufuca (2014). We present results either for a monopoly choosing the minimum quality and for a monopoly choosing the maximum quality.

Monopoly (Single Product): Subscription Fee and Advertising Intensity

According to the above assumptions, the platform maximizes profits, subject to a positivity constraint on advertising level.

$$\begin{cases} \max_{a_H, s_H} \Pi_M = B_M(s_M + \rho_M) - K \\ s.t. a_M \geq 0 \end{cases} \quad (2.6.30)$$

First order conditions with respect to the advertising spaces a_M and subscription fee s_M are respectively:

$$\frac{\partial \Pi_M}{\partial a_M} = \frac{\partial B_M}{\partial a_M} s_M + r_M + a_M \frac{\partial r_M}{\partial a_M} \leq 0 \quad (2.6.31)$$

and

$$\frac{\partial \Pi_M}{\partial s_M} = B_M + \frac{\partial B_M}{\partial s_M} s_M + a_M \frac{\partial r_M}{\partial s_M} = 0 \quad (2.6.32)$$

Then, according to the literature, we define the advertising revenues per viewer as:

$$\rho(a_i) = \frac{a_i r_i}{B_i} = \frac{a_i F^{-1}(1 - a_i) B_i}{B_i} = a_i F^{-1}(1 - a_i) \quad (2.6.33)$$

We assume $\rho(a_i)$ to be concave in the interval $a \in [0, 1]$. Given that $\rho(a_i) = 0$ for $a_i = 0$ and $a_i = 1$, the function is single-peaked.

Using the definition (2.6.33) for the monopoly platform we can rewrite optimality conditions, proving the following Proposition.

Proposition 17. *The optimal advertising level of the monopoly single-channel broadcaster is:*

$$\rho'(a_M) = \delta$$

Proof. Given (2.6.33) for the monopoly platform

$$\rho(a_M) = \frac{a_M r_M}{B_M} = \frac{a_M F^{-1}(1 - a_M) B_M}{B_M} = a_M F^{-1}(1 - a_M) \quad (2.6.34)$$

we have:

$$r_M = \frac{B_M \rho(a_M)}{a_M} \quad (2.6.35)$$

Therefore optimality conditions (2.6.31) and (2.6.32) rewrite into (2.6.36) and (2.6.37):

$$s_M \frac{\partial B_M}{\partial a_M} + r_M + a_M \left[\frac{(B_M \rho(a_M) + \frac{\partial B_M}{\partial a_M} \rho(a_M)) a_M - B_M \rho(a_M)}{a_M^2} \right] \leq 0 \quad (2.6.36)$$

$$B_M + s_M \frac{\partial B_M}{\partial s_H} + a_M \frac{\partial r_M}{\partial s_M} = 0 \quad (2.6.37)$$

By easy calculation, (2.6.36) and (2.6.37) become respectively:

$$\frac{\partial B_M}{\partial a_M} (s_M + \rho(a_M)) + B_M \rho(a_M) \leq 0 \quad (2.6.38)$$

$$\frac{\partial B_M}{\partial s_H} (s_M + \rho(a_M)) + B_M = 0 \quad (2.6.39)$$

Given that $\frac{\partial B_M}{\partial a_M} = -\frac{\delta}{\theta_M}$ and $\frac{\partial B_M}{\partial s_M} = -\frac{1}{\theta_M}$, we get:

$$\frac{\partial B_M}{\partial a_M} = \delta \frac{\partial B_M}{\partial s_M} \quad (2.6.40)$$

Therefore, plugging in (2.6.38) and (2.6.39), we get the following system:

$$\begin{cases} \delta \frac{\partial B_M}{\partial s_M} (s_M + \rho(a_M)) + B_M \rho'(a_M) \leq 0 \\ \frac{\partial B_M}{\partial s_H} (s_M + \rho(a_M)) + B_M = 0 \end{cases} \quad (2.6.41)$$

Finally, if $a_M > 0$ the above inequality is satisfied with equality. Therefore, given that $\rho(a_M)$ is single-peaked, a_M is uniquely determined by the following condition:

$$\rho'(a_M) = \delta.$$

□

We can now solve for the equilibrium values, as stated in the following proposition.

Proposition 18. *With $\rho(a_M)$ concave, we obtain the equilibrium price s_M^* and demand B_M^* as function of quality, revenues per viewer and advertising level.*

Proof. By plugging the expression for B_M in the optimality condition (2.6.39) we obtain:

$$s_M^* = \frac{V + \theta_M - \rho(a_M^*) - \delta a_M^*}{2} \quad (2.6.42)$$

Then,

$$B_M^* = \frac{V + \theta_M + \rho(a_M^*) - \delta a_M^*}{2\theta_M} \quad (2.6.43)$$

□

Proposition 18 shows the result of profit neutrality. Indeed, an increase in revenues on the advertising side are counterbalanced by a decrease on the subscription fees.

Monopoly (Single Product): Platform's quality

In order to solve the quality stage, we maximize the monopoly profit, $\Pi_M(s_M^*, a_M^*, r_M^*, \theta_M)$, with respect to the quality, θ_M . We obtain the following FOC, subject to $\theta_M \geq 0$:

$$\frac{\partial \Pi_M(s_M^*, a_M^*, r_M^*, \theta_M)}{\partial \theta_M} = \frac{(V + \theta_M + \rho(a_M^*) - \delta a_M^*)(\theta_M - \rho(a_M^*) + \delta a_M^*)}{4\theta_M^2} = 0 \quad (2.6.44)$$

Unfortunately, in this general framework we cannot calculate the equilibrium value of θ_M^* .

By calculating the second order conditions we show the convexity of the profit function:

$$\frac{\partial^2 \Pi_M}{\partial \theta_M^2} = \frac{(\rho(a_M^*) - \delta a_M^*)^2}{2\theta_M^3} \geq 0 \quad (2.6.45)$$

Given convexity, the monopoly platform will reach one of the boundaries, choosing $\underline{\theta}$ or $\bar{\theta}$. Hence we describe two possible local equilibria, each of them characterized by a specific configuration of the technological range.

Proposition 19. *In equilibrium, under the technological constraint $\Theta_{RL} = [\underline{\theta}, \bar{\theta}]$ with $\underline{\theta} = \rho(a_M^*) - \delta a_M^*$, the monopoly platform chooses the maximum quality.*

Differently, under the technological constraint $\Theta_{RH} = [\underline{\theta}, \bar{\theta}]$ with $\underline{\theta} > 0$ and $\bar{\theta} = \rho(a_M^) - \delta a_M^*$, the monopoly platform chooses the maximum quality.*

Proof. In the first case we restrict ourselves on the increasing slope of the profit function. By comparing monopoly profit functions in $\underline{\theta}$ and $\bar{\theta}$, respectively:

$$\Pi_M^*(\underline{\theta}) = \frac{(\underline{\theta} + \rho(a_M^*) - \delta a_M^*)^2}{4\underline{\theta}} - K$$

$$\Pi_M^*(\bar{\theta}) = \frac{(\bar{\theta} + \rho(a_M^*) - \delta a_M^*)^2}{4\bar{\theta}} - K$$

we get:

$$\Pi_M^*(\bar{\theta}) - \Pi_M^*(\underline{\theta}) > 0$$

For $\theta \in \Theta_{RL}$ profit are convex and increasing in quality. Therefore to maximize profit the monopoly platform sets $\theta_M^* = \bar{\theta}$.

In the second case, we restrict ourselves on the decreasing slope of the profit function. By comparing monopoly profit functions in $\underline{\theta}$ and $\bar{\theta}$, respectively we get:

$$\Pi_M^*(\bar{\theta}) - \Pi_M^*(\underline{\theta}) < 0$$

For $\theta \in \Theta_{RH}$ profit are convex and decreasing in quality. Therefore to maximize profit the monopoly platform sets $\theta_M^* = \underline{\theta}$. \square

Considering the uniform case, we can suggest some interesting insights. By easy calculation, in the uniform case with $\rho(a_M) = a_M(1 - a_M)$, we obtain:

$$a_M^* = \frac{1 - \delta}{2} \quad (2.6.46)$$

$$s_M^* = \frac{V + \theta_M - \delta a_M^* - \rho(a_M^*)}{2} = \frac{V + \theta_M - \left(\frac{1-\delta}{2}\right) \left(\frac{1+3\delta}{2}\right)}{2} \quad (2.6.47)$$

$$B_M^* = \frac{1}{2\theta_M} \left[V + \theta_M + \left(\frac{1-\delta}{2}\right) \left(\frac{1-\delta}{2}\right) \right] \quad (2.6.48)$$

According to the equilibrium solutions of stage 3 and stage 2, the profit function - in the uniform case - becomes:

$$\Pi_M^* = B_M^*(s_M^* + \rho_M^*) - K = \frac{1}{4\theta_M} \left(V + \theta_M + \left(\frac{1-\delta}{2}\right)^2 \right)^2 - K \quad (2.6.49)$$

Given our result on quality if we consider the case of Θ_{RL} , we obtain equilibrium values for subscription fees and viewers' demand:

$$s_M^* = \frac{V + \bar{\theta} - \left(\frac{1-\delta}{2}\right) \left(\frac{1+3\delta}{2}\right)}{2} \quad (2.6.50)$$

$$B_M^* = \frac{1}{2\bar{\theta}} \left[V + \bar{\theta} + \left(\frac{1-\delta}{2}\right) \left(\frac{1-\delta}{2}\right) \right] \quad (2.6.51)$$

$$\Pi_M^* = \frac{1}{4\bar{\theta}} \left(V + \bar{\theta} + \left(\frac{1-\delta}{2}\right)^2 \right)^2 - K$$

For the case of technological range Θ_{RH} equilibrium results are unchanged but for quality.

Monopoly (Single Product): Viewers' surplus

Viewers' surplus is:

$$\begin{aligned} SC_M &= \int_0^{\beta_I} (u_0) d\beta + \int_{\beta_I}^1 (u_M) d\beta \\ &= \frac{1}{2} (1 - \beta_I^2) (\theta_M) + (1 - \beta_I) (V - s_M - \delta a_M) \end{aligned}$$

Substituting equilibrium values for β_I , s_M , a_M and θ_M , we get

$$SC_M(\bar{\theta}) = \frac{1}{8\bar{\theta}} (V + \rho(a^*) - \delta a^* + \bar{\theta})^2 \quad (2.6.52)$$

if Θ_{RL} and

$$SC_M(\bar{\theta}) = \frac{1}{8\underline{\theta}} (V + \rho(a^*) - \delta a^* + \underline{\theta})^2 \quad (2.6.53)$$

if Θ_{RH} .

Part II

Political Economy of Mass Media

Chapter 3

Information, Media and Elections: Incentives for Media Capture ¹

3.1 Introduction

The political race to public offices is not limited to electoral competition between candidates but it also includes issues on information acquisition by the electorate. How political information is collected and selected by sources of information and when news are acquired by voters, are essential elements to be considered. In situations of uncertainty about the quality of political candidates, media outlets play an essential role by making available valuable information for electoral decisions. By learning more about candidates, voters are more likely to replace bad types with good ones. However, this may arise a risk of attempts to media's freedom. If media are meant to discipline politicians, we would expect politicians to view them as a threat. In particular, if they are office-motivated agents, they will find ways to silence critics and to foster positive coverage. ²

Related literature on media capture

Despite the essential role played by news media in modern democracies, the economic literature has started analysing the market for news only recently. However, this literature has grown rapidly over a large range of research questions. In particular, there is a growing number of contributions discussing the role and the effects of news media on political and public outcomes and inquiring the existence of distortions in the market for news. For a complete overview of the literature on the political economy of news media, there are two extensive surveys: Prat and Strömberg (2011) and Sobbrío (2014).

Focusing on the interaction within the media industry and between the media and other agents, an issue of particular interest has been the possibility for media to provide distort information. Media outlets may compete for audiences by presenting information in a biased way (media bias as *news slanting*). Differently, distortion may come for "outside", when media are prevented from performing their informational task (*media capture*). These phenomena may prevent the functioning of the market, skew electoral competition and produce negative political outcome. ³

Regarding media bias as *news slanting*, the literature has identified two different forces creating a bias in media reporting: a supply-driven bias and a demand-driven media bias. The first arises from idiosyncratic preferences of agents involved in the production of news (ideological bias of reporters Baron (2006)) whereas the second bias occurs in equilibrium because of cognitive bias of audiences (Mullainathan and Shleifer (2005), Chan and Suen (2008), Sobbrío (2014)) or because of reputational

¹This chapter refers to the paper Drufuca 2014 "Information, Media and Elections: Incentives for Media Capture", Working Papers (2013-) 1402, University of Bergamo, Department of Management, Economics and Quantitative Methods.

²I would like to thank Paolo Bertoletti for his revision and helpful comments. This paper has also benefited from the discussion and comments of seminar participants at the 4th EARIE Annual Conference.

³See Blasco and Sobbrío (2012).

issues in presence of heterogeneous beliefs (Gentzkow and Shapiro (2006)). Instead, *media capture* is a form of distortion which is linked to interaction between media and agents outside the industry.

Media capture may arise from different sources. On one side, in an electoral context where agents have common interests, it may come from incumbent candidates trying to hide their true quality in order to be re-elected or it may come from the government trying to misreport the real value of public project in order to extract tangible rents. In this sense media capture can be considered as the consequence of an incumbency advantage. For instance, Besley and Prat (2006) present a model of incumbency advantage and endogenous media capture, stating conditions under which capture is more likely to occur and describing its effects on political outcome. They show how in a situation of asymmetric information about the quality of candidates, an increase in the number of news media is likely to make capture more difficult and to rise turnover of politicians. Differently, Prat and Strömberg (2011) build a model of retrospective voting and endogenous coverage, showing that political equilibria depend on how informed different social groups are and that an increase in news coverage increases on average the Incumbent's vote share and the effort of politicians towards informed groups.

On the other side, media capture may come from other sources when there are no common interest among agents. If the electorate is heterogeneous, news media can collude with interest groups or lobbies (Corneo (2006)) or with the richest groups of voters (Petrova (2008)).

Regarding the empirical literature, there is a strong evidence suggesting that media capture exists both within and cross-country ⁴. However, the nature of the evidence does not allow for strong conclusions regarding causal effects. The most convincing case is provided by McMillan and Zoido (2004), who reconstruct the system of bribes created during Alberto Fujimori's presidency of Peru ⁵ providing direct proof of the existence of capture. Moreover, their analysis identifies patterns that are consistent with the theoretical results of Besley and Prat (2006).

My contribution and plan of work

I provide a simple theoretical framework composed by three stages: provision of news, acquisition of information and elections. The objective is to identify which incentives exist for individuals to get informed before elections and why politicians may spend resources to control information. The model is similar to the one of Besley and Prat (2006), where choice-relevant information is traded in a market for news just before elections. In this market media outlets are specialized in gathering and transferring news to an homogeneous audience. Incumbent candidates may interact with these media outlets in order to distort information and to maximize the probability of holding their office.

Differently from their setting, I consider an heterogeneous environment where voters decide whether or not to access media's contents to get informed about the "quality" of candidates, determining endogenously a demand for news. In particular, my work analyses the endogenous acquisition of information by voters with heterogeneous costs and it shows under which conditions media capture may arise.

The work is organized as follows. In Section 3.2, I present the setup and the timing of the game. In Section 3.3 I look for equilibrium solutions in a simplified version without media capture and with a truthful reporting monopolist media. I consider all the stages involving voters, looking for conditions ensuring the existence of equilibrium strategies in order to determine endogenously the demand for news. Then I derive equilibrium solutions respectively for media outlets' stage and politicians' stage. Comparative statics is done by considering changes in the relevant features (parameters, number of firms, quality of signal, etc.). Finally, in Section 3.4, since equilibrium strategies obtained show the existence of incentives to corruption, I introduce the possibility of media capture. Incumbent's choice about capturing media will be influenced by the conditions defined in previous stages, since victory is determined by priors, posteriors, price and demand for news.

⁴Cross-country evidence of capture: Brunetti and Weder (2003); Djankov et al. (2003). Within-country evidence of capture: Di Tella and Franceschelli (2011); Petrova (2009); Dyck and Zingales (2004); Dyck, Volchkova and Zingales (2008); Gambaro and Puglisi (2010).

⁵Fujimori had been president from 1990 to 2000.

3.2 The Model

3.2.1 Set up

In a framework of electoral competition, information about candidates may affect individual decisions concerning both allocation of private resources and political choices. Indeed, political news are valuable during elections since they help individuals to choose the best candidate or to anticipate the possibility of a bad one. This relevant information can be traded in a market for news by outlets specialized in gathering and transferring news.

Getting informed is however a costly activity which involves, besides a price of accessing news, opportunity costs composed essentially by time and cognitive effort. These opportunity costs of processing information can be linked to individual characteristics (such as QI and education ⁶), resulting in different individuals devoting more or less time to news consumption. Exploiting this intuition, I consider an audience composed by rational individuals, heterogeneous regarding their *costs of information*, who use news as support for electoral choices and private decisions. This heterogeneity allows me to identify a group of informed individuals and a group of uninformed ones, in order to derive an endogenous demand for news depending on priors about candidates' types, access-price, information costs and quality of news.

When elections come, voters have to choose between re-electing the Incumbent and choosing an Opponent. Voters are uncertain about the quality of candidates and, consistently with part of the literature on media bias, I model this uncertainty as a game of incomplete information. Two states of the world are possible, a “bad” politician ($x = 1$) and a “good” politician ($x = 0$). These states correspond to different types of politician running for elections. The Incumbent and the Opponent have the same distribution of types: Nature selects “good” with probability $1 - p$ and “bad” with probability p . Since Incumbent's type is realized before elections, media outlets receive some information about it and individuals can update their beliefs about Incumbent's quality by accessing media's content.

Viewers Each individual derives the following pay-off when a politician of type x is in office:

$$U(x) + T \times I(a_i, x) - C_i - P_A \quad (3.2.1)$$

Voters derive a direct utility $U(x)$ from the type of politician holding the public office. I assume $U(x)$ to be invariant across individuals and that $U(1) = 0$ and $U(0) = 1$. This direct utility is a common evaluation of the state: a bad politician is considered by everyone as a negative situation. Due to the shared nature of this evaluation, each candidate has incentive to signal a good state in order to be elected.

In addition, voters may incur in a gain in consumption conditioned by the state and by the choice of a private action a_i . If individuals correctly anticipate the state, they can overwhelm it by matching it with a “correct” private action. This additional gain in utility varies across individuals and it is expressed as an indicator function which take value 1 if the action matches the state ($a_i = x$) and zero otherwise. Moreover, the impact of choosing the correct action is set in general terms as T , which can be greater, equal or lower than the direct impact of the state.

Since media receive some information about the type of Incumbent running for the office, individuals can improve their priors by accessing news. The costs of getting informed are composed by the price of news P_A and individual costs of information C_i . We can consider P_A as an access cost and C_i as individual opportunity costs of processing news in valuable information. Voters are heterogeneous in their costs of information C_i ⁷ which are assumed to be uniformly distributed on a positive support.

⁶In a recent paper, Battaglion and Vaglio (2012) considered issues of information acquisition in an heterogeneous environment, linking opportunity costs to individual levels of information.

⁷These costs may depend on individual characteristics. Intuitively and consistently with the previous intuition, acquiring information on the political state is a costly activity in terms of time, effort and individual capabilities. A good proxy for these costs can be the inverse of individual education: education reduces the costs of acquiring information in terms of psychic costs, effort and time. See Battaglion and Vaglio (2012).

Media Outlets Media outlets receive information about the type of Incumbent competing in the political arena and they may report it to voters by supplying news. News are reporting strategies of signals received by media about the type of politician in office. In this perspective, it is reasonable to overlook the issue of news creation by assuming no costs of production.

According to the media capture literature (see Besley and Prat (2006)), media outlets receive a signal just about the negative event.⁸ If the Incumbent is of a good type, media receive an empty signal $s = \emptyset$ with probability equal to 1. Instead, if the Incumbent is of a bad type, the signal is $s = b$ (*true signal*) with probability q and $s = \emptyset$ (a *false signal* which is the same signal as in the case of a good politician) with probability $1 - q$. In this kind of framework q is treated as the quality of signals.⁹ The empty signal $s = \emptyset$ can be interpreted as the absence of news about the Incumbent being bad.

Media outlets have two sources of revenues: audience-related revenues and policy-related revenues. Each of them refers to the interaction of media outlets with their audience¹⁰ and with the Incumbent.

$$\text{audience-related revenues} = P_A \times D(C, P_A, q) \quad (3.2.2)$$

$$\text{policy-related revenues} = y \quad (3.2.3)$$

Audience-related revenues are standard in the literature and they depend on the price of the service, the fixed price of accessing media content P_A , and the demand for news. By assuming that each individual can just “consume” one piece of information, the demand for news can be identified with the number of individuals willing to pay for accessing the media content given the price, their information costs and quality of news.¹¹

On the other side, *policy-related* revenues derive from the interaction between media outlets and politicians in office: revenues are introduced when there is possibility for media to non-truthfully report signals and when politicians have means and incentives to capture outlets. They can offer a “bribe” y to each outlet: y is set in general terms and it may represent monetary bribes but also any other attempt to silence critics and to foster positive coverage. For each outlet, y has value 0 when the bribe is refused and it is positive otherwise. Notice that these are *unconditional payments* for what concern the election of the Incumbent.

Politicians Several motivations can explain why politicians compete for holding public offices. They can be moved by policy outcomes and they desire to implement their preferred policies because of ideology or to favour special interest groups (*partisan politicians*); others may seek personal satisfaction from being in power or merely seek the benefits of holding the office (*opportunistic politicians*).

The issue of motivation has been prominent in the study of elections which has tried to understand whether candidates view public office as a mean or as a goal in itself. One stream of literature, following Hotelling (1929) and Downs (1957) considers opportunistic *office-motivated* and *rent-motivated* candidates, whereas an opposite stream proposed by Wittman (1977; 1983), Calvert (1985) and Alesina (1988) considers them as *policy-motivated* and partisan. Recently, this dichotomy of opposite views has been criticized by Persson and Tabellini (2000) as an imperfect understanding of ideology in politics. They argue that either *opportunism* or *partisanship* is always the best assumption and that the two are not necessarily mutually exclusive, rising new attention to the issue of motivations. A new stream of models tried to respond to the challenge posed by Persson and Tabellini, integrating both office motivations and policy motivations (see Besley and Ghatak (2005) and Callander (2008))¹².

⁸I considered also the possibility of a framework with a double-signal structure. However I do not present results on this alternative setting since they do not add any useful insight.

⁹In this framework q is treated as an exogenous variable. In a possible extension, it could be interesting to consider q as the result of a investment decision and let it be part of the media’s maximization strategy.

¹⁰I do not consider a specific kind of audience. Media outlets considered can be of any kind (newspaper, television, radio, etc.). I usually refer to media’s audience as *viewers*. However this term, doesn’t imply any restriction to the kind of audience. Sometimes I use the terms *consumers*, *individuals* and *voters* to name audience.

¹¹ C stands for the uniform distribution of individual costs of information.

¹²For a complete discussion of the literature on political motivation see Persson and Tabellini (2000) and Besley (2006).

In this model I consider a situation of opportunistic *rent-seeking* politicians, who care about winning the election but also about extracting tangible rents for themselves¹³. By assuming politicians to be rent-seeking officers, it is possible to introduce incentives to capture media in order to give a certain signal, since these officers just care on the probability of being re-elected and not on the policies they have to implement.

The possibility of media capture, is an exclusive feature of incumbency, one of the structural advantages of candidates in office over challengers during elections. Even if the Challenger¹⁴ has the same prior probabilities on states, he has no means to influence media's reports and always acts as a *passive agent*. In this framework, Incumbent's pay-offs are

$$ER - \sum_{j=1}^n y_j \quad (3.2.4)$$

Obviously, Incumbent's rent is expressed in expected terms and has to be conditioned on the probability of being elected. The Incumbent gets a positive rent R if elected and 0 otherwise; in both cases, he has to subtract the total cost of bribing if he decides to corrupt media outlets. The total cost of bribing is the sum of bribes y_j accepted by each outlet j . Since the bad state reduce utility of all voters, the Incumbent has the incentive to capture media in order to give a positive signal and to maximize the probability of being elected; however he will corrupt media only if the net rent from holding the office $ER - \sum y_j$ is positive. In addition to the costs of bribing, a politician can incur in the possibility of being detected and punished while corrupting media.

3.2.2 Timing

The game can be summarized as follows. There are three stages, one for each kind of actor, namely politicians, media outlets and voters. Voters' stage is composed by three different sub-stages.

- Stage 1: Politicians Stage: Incumbent's Capture strategies
- Stage 2: Media Stage: Pricing and Reporting strategies
- Stage 3: Voters Stage: Information Decision, Action Choice and Electoral Choice

The timing of the game is the following:

- Nature selects Incumbent's type (B or G); the Incumbent and media observe signals this type;
- the Incumbent decide whether or not to corrupt media by offering a bribe;
- media decide their reporting strategies: to accept the bribe or to truthfully report the signal;
- voters decide either or not to get informed; informed voters observe the report and update beliefs;
- all individual chooses private actions;
- elections are held between the Incumbent and an Opponent; the elected politician implements policy according to his type (pay-offs realization).

I characterize perfect bayesian equilibria of this game, solving backward the stages for voters, media outlets and politicians.

3.3 Equilibrium under Truthful Reporting

I start with a simplified version of the model where I eliminate the possibility of capture by taking for granted that media have a strategy of truthful reporting of signals ($r = s$) and by assuming the absence of revenues other than market profits (no policy-related revenues). Hence, in all stages, I just

¹³See chapter 4 in Persson and Tabellini (2000).

¹⁴I refer to the candidate challenging the Incumbent both as Opponent and as Challenger.

consider signals and I do not take into account the choice of Incumbent to bribe or not media outlets. Both the Incumbent and the Opponent act as passive agents. Moreover, media market is assumed to be non-competitive: I consider a monopolist media outlet that maximizes profits from the sale of news by choosing an optimal access price to its content (P_A). This simplified model is fundamental to check if it is possible to find the conditions needed to guarantee incentives for the Incumbent to corrupt media, once policy-related revenues are introduced, and it will be used as a benchmark.

3.3.1 Voters

I consider all the stages involving voters, looking for conditions ensuring the existence of equilibrium strategies. At first, each individuals have to decide whether or not to be informed, taking into account costs and benefits from accessing news; secondly, they have to decide which private action to choose, knowing that it will interact with the type of the politician elected; finally, they have to select which candidate they should vote for. It is important to point out that the electoral stage involves a simple model of retrospective voting with no pivotal considerations and no individual preferences for candidates or parties (*sincere voting*). Voters compare candidates just on the base of expected utilities from their types.¹⁵ Moreover, I exclude the presence of costs of voting and the possibility of abstention.¹⁶

Electoral stage

At the electoral stage voters have to choose between two competing candidates with a certain probability of being of bad type: the Incumbent and an Opponent. As already stressed, they vote sincerely for the candidate providing the highest expected utility. Expected utilities depend on priors and signals about the type of politicians competing. The distribution of types is the same for the two candidates; however, Incumbent's type is realized before the electoral stage and voters can access information about him through media reports. The main difference between the expected utility from the Incumbent (EU_I) and the expected utility from an Opponent (EU_O) is that the first must incorporate the information received from media, if voters are informed. Individual actions are taken before the electoral choice and are considered as given at this stage.

Since only a part of voters acquire information, I distinguish between uninformed individuals and informed ones: in the first case the expected utilities from Incumbent and Opponent are equal since there is no update, the two politicians have the same distribution of types and are no no ideological preferences. By assuming that individuals vote just considering expected utility without taking into account the probability of victory of candidates (no pivotal voting strategy), the only reasonable behaviour for uninformed voters is the mixed strategy of voting with 50% of probability for each candidate.¹⁷ On the other hand informed individuals condition their choice on the report received from media by updating their prior beliefs.

¹⁵The baseline of the election game is a pure adverse-selection model where the policy outcome is a function solely of the politician's type.

¹⁶Every individuals will be voters. Hence, I use the two terms has synonymous.

¹⁷It is possible to relax this assumption by considering a more general mixed behaviour, but it will complicate the analysis without adding any insight.

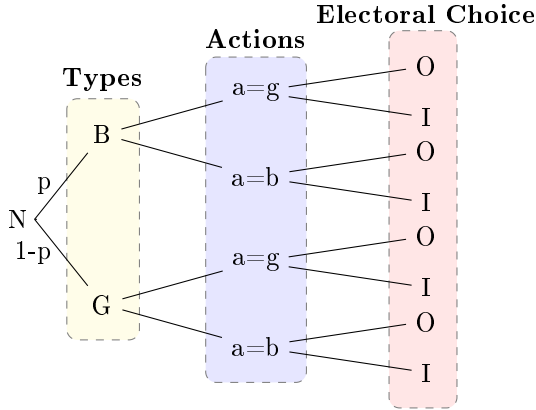

Figure 3.3.1: Game scheme for uninformed

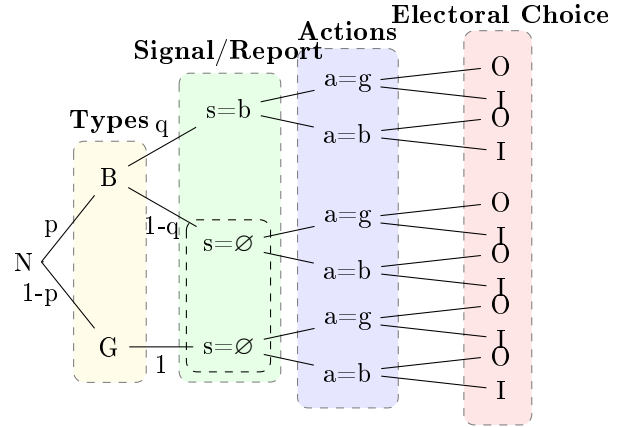

Figure 3.3.2: Game Scheme for informed

In the simplified version of the model I consider a situation of *truthful reporting* ($r = s$) where each media report the signal received about Incumbent's type. In this situation, I consider signals s instead of reports r also in voters' stages.

Equilibrium moves in the electoral stage are obtained excluding degenerate values for the probability of negative event (p) and for the quality of signals (q) and assuming $T \in (-1, 1)$. The latter condition implies that the impact of private action $I(a_i, x)$ is inferior (in percentage) with respect to the direct impact of the state on utility. I describe the equilibrium voting behaviour for informed individuals in the following proposition:

Proposition 20. *Given probability $p \in (0, 1)$ and probability $q \in (0, 1)$ and assuming $T \in (-1, 1)$, an informed individual prefers - and thus votes - the Opponent if he receives a report $s = b$; instead he prefers the Incumbent if he receives a report $s = \emptyset$. This behaviour is optimal independently from the action in the previous stage and from the sign of their impact (T) .*

[see proof 3.6.1 in the Appendix]

Proposition 20 states that an informed individual does not vote for the Incumbent if he receive *bad news* about him. In case of absence of bad news, he is willing to re-elect him. This kind of behaviour is essential to induce media capture by politicians: since voters prefers the Opponent if they receive a signal about the Incumbent being bad, the latter has an incentive to silence media in order to increase the probability of winning the election.

Action Choice stage

From the electoral stage, under the assumption of $p \in (0, 1)$ $q \in (0, 1)$ and $T \in (-1, 1)$ (see Proposition 20), individuals correctly anticipate that they will vote for the Opponent if they receive news about the Incumbent being of bad type, whereas they will prefer the Incumbent with 50% probability if uninformed.

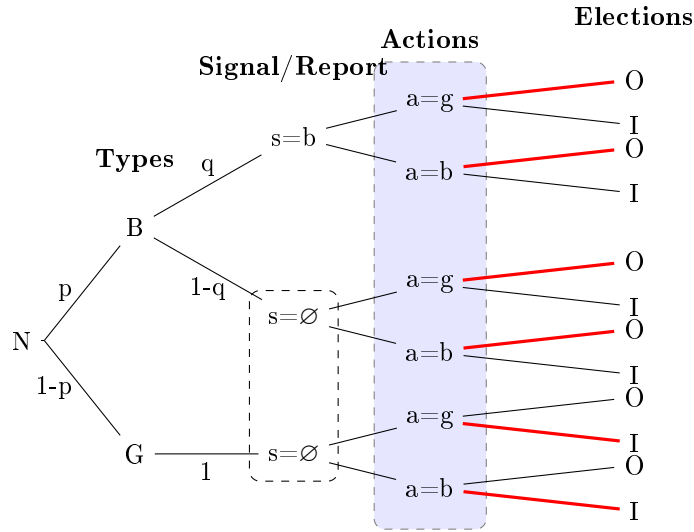

Figure 3.3.3: From electoral stage: backward solution

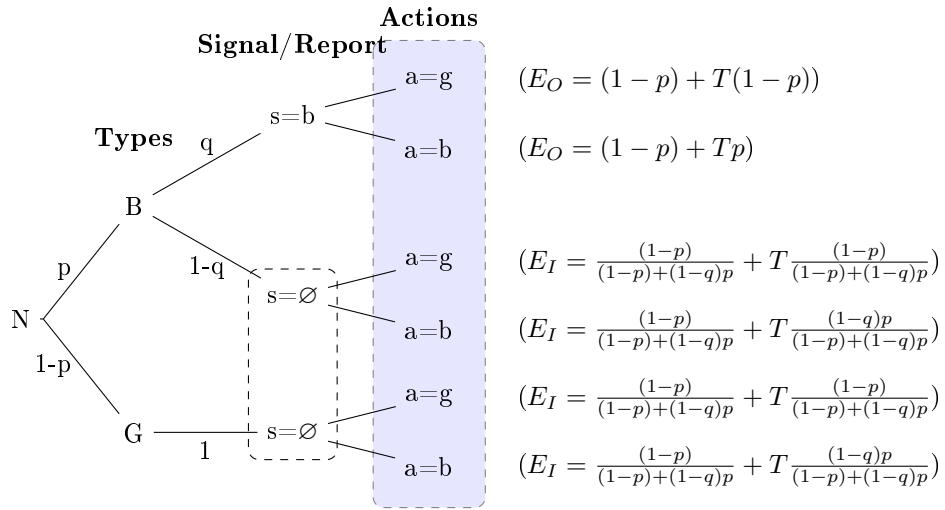

Figure 3.3.4: From electoral stage: expected pay-offs

At this stage individuals choose their private actions in order to compensate the possibility of a negative state. If the state is bad they should set $a_i = b = 1$ and $a_i = g = 0$ otherwise. In choosing their action informed individuals take into account their expected utility conditioned on the report received from media and their behaviour in the electoral stage; uninformed individuals condition their choice on priors. In the following proposition I derive equilibrium choice of actions. Assumptions on priors and signal's quality are identical to those in Proposition 20, whereas I slightly modify the condition on the impact of private action (T), assuming it to be positive and inferior (in percentage) with respect to the direct impact of the state on utility.

Proposition 21. *Given probability $p \in (0, 1)$ and probability $q \in (0, 1)$ and assuming $T \in (0, 1)$, an individual will choose his private action according to the information received, the probability of negative event and the quality of media's signal:*

1. *If $s = b$, informed chooses*
 - a) $a = b$ if $p > 1/2$
 - b) $a = g$ if $p < 1/2$
2. *If $s = \emptyset$, informed chooses*
 - a) $a = b$ if $p > 1/2$ and $(1 - p) < p(1 - q)$
 - b) $a = g$ if $p < 1/2$ and $(1 - p) > p(1 - q)$
 - c) $a = g$ if $p < 1/2$
3. *Uninformed chooses*
 - a) $a = b$ if $p > 1/2$
 - b) $a = g$ if $p < 1/2$

[see Proof 3.6.2 in the Appendix]

To summarize, from the electoral stage imposing that $p \in (0, 1)$ $q \in (0, 1)$ and $T \in (-1, 1)$ individuals anticipate that they will vote for the Opponent if they receive news $s = b$ and for the Incumbent if $s = \emptyset$. Moving to the action choice stage, pure optimal moves exist only by considering separately when the negative event is ex-ante more ($p > 1/2$) or less ($p < 1/2$) likely to occur.¹⁸ Hence, from now on, I consider these two situation separately looking for equilibrium behaviours.

When $p < 1/2$, informed individuals vote according to the report received and used it to update priors probabilities, but they behave as uninformed always choosing $a_i = g = 0$. Instead, when negative state is ex-ante more likely, the kind of report becomes important. In this situation, when individuals receive bad news about the Incumbent ($s = b$), the signal is likely to be correct and they act consistently ($a_i = b = 1$); if individuals don't receive news about the Incumbent being bad when is more likely that the state is b , the quality of signals q ¹⁹ has to be high to make them believing the signal. We can interpret $p(1 - q)$ as the probability of a false signal. Hence, informed individuals uniform a_i to the report. if the probability of a false signal is sufficiently low ($p(1 - q) < 1 - p$); vice versa, they act as uninformed by choosing always $a_i = b = 1$.

Information stage

Information stage concerns individual choice about getting informed. Since information is a costly activity, some individuals may find profitable to remain uninformed. If voters have sufficiently high costs of information, these may overcome the gains of being informed. Costs are composed by two parts: in addition to a *fixed access price* P_A set by media, individuals have to sustain *individual information costs* C_i when they decide to get news. Information costs are a fundamental in this theoretical settings since they represent the element of heterogeneity. Information costs are heterogeneous across individuals and they can be thought as linked to personal characteristic (education, as example). In order to capture this heterogeneity, C_i is assumed to be distributed over a positive support;²⁰ the cumulative distribution of individual with a sufficiently low cost of information will represent the share of informed voters. At this point, I distinguish the expected utility of an uninformed individual from

¹⁸I overlook the threshold case of $p = 1/2$.

¹⁹Recall that in the simplified version $r = s$.

²⁰A complete discussion is provided in the next section.

that of informed one by introducing costs of information and compute them exploiting equilibrium strategies derived in the previous stage.²¹

Expected utility of informed individuals Informed individuals take into account the price of accessing media P_A and their personal information costs C_i . Their expected utility depends on the state, on private actions and on the signal received by media,²² having assumed truthful reporting. If individuals are informed, they should have found convenient to sustain the costs of information in order to condition their choice on the news they have accessed and to update their beliefs about the Incumbent.

$$EU(s, a_i) - C_i - P_A \tag{3.3.1}$$

where $EU(s, a_i,)$ is the expected utility from the future politician in office, conditioned on the received signal s and given private action a_i .

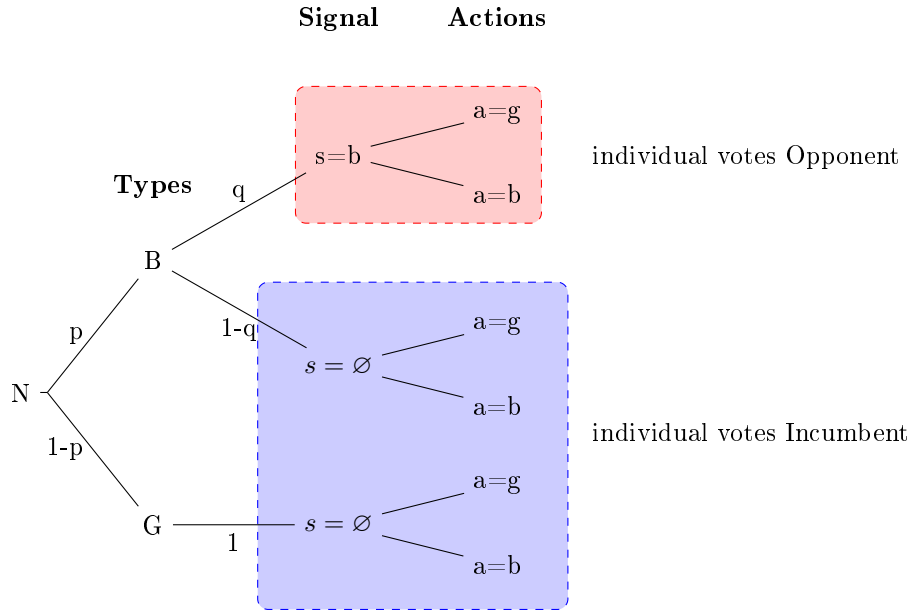

Figure 3.3.5: Equilibrium moves in electoral stage for informed individuals

Informed individuals condition their choices both on the distribution of politicians' types and on news' content. Differently from uninformed individuals, they take into account the kind of signal received (s) and its quality (q).

Lemma 4. *Given $p \in (0, 1)$, $q \in (0, 1)$ and $T \in (0, 1)$, the expected utility of an informed individual is:*

- (CASE A) $EU = pq[(1 - p) + T(1 - p)] + (1 - p)[1 + T] - C_i - P_A$ if $p < 1/2$
- (CASE B) $EU = pq[(1 - p) + Tp] + (1 - p)[1 + T] - C_i - P_A$ if $p > 1/2$ and $(1 - p) > (1 - q)p$

²¹When I compute these utilities I consider two different cases: a situation of high probability of the bad state ($p > 1/2$) and a situation of low probability of the bad state ($p < 1/2$). By considering these two situations separately, I am able to derive the expected utilities since I know voters equilibrium strategies for the other voters' stages (individual action and electoral choice).

²²Since report and signal don't diverge $r = s$.

- (CASE C) $EU = pq[(1-p) + Tp] + p(1-q)[T] + (1-p) - C_i - P_A$ if $p > 1/2$ and $(1-p) < (1-q)p$

[see Proof 3.6.3 in the Appendix]

Expected utility of uninformed individuals There are no differences among uninformed individuals: by not reading, individuals do not sustain information costs (heterogeneous element). In this case there is no possibility of update since no report is received.

$$EU(a_i) \tag{3.3.2}$$

where $EU(a_i)$ is the expected utility from the future politician in office, given action a_i .

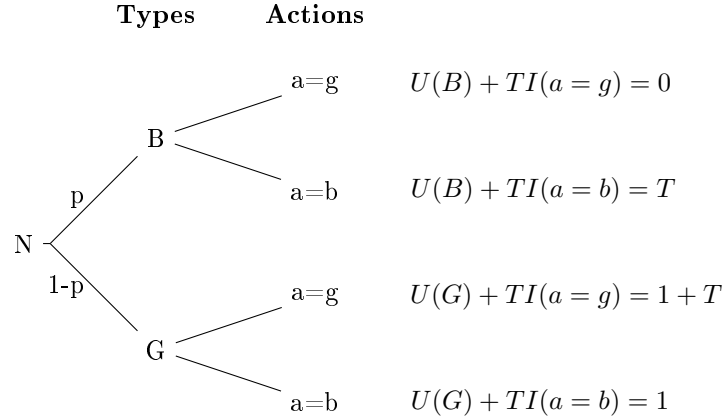

Figure 3.3.6: Pay-off in the action stage for uninformed individual

In the electoral stage, uninformed voters are assumed to vote 50% for the Incumbent and 50% for the Opponent since there are no preferences other than the utility derived from the type of politician elected and the expected pay-off of matching private actions. Without information, the expected utility from the two candidate is the same and it is realistic to assume that individuals choose this mixed strategy. Hence, the only “decision” is about private actions ($a = g$ or $a = b$).

Lemma 5. *Given $p \in (0, 1)$, $q \in (0, 1)$ and $T \in (0, 1)$, the expected utility of an uninformed individual is*

- $EU = (1-p) + Tp$ if $p > \frac{1}{2}$
- $EU = (1-p) + T(1-p)$ if $p < \frac{1}{2}$

[see Proof 3.6.4 in the Appendix]

Voters are heterogeneous in their costs of processing news C_i and this determines that a share of them will find convenient to acquire information since their expected utility is greater than in case of no information. To be this the case, I need expected utility of informed, included all information’s costs, to be greater than the expected utility of uninformed at least for some value of C_i . This is true if the difference between the two expected utilities is greater than zero, since both P_A and C_i are positive; after that I compute the cost C_I (one for each case) identifying the individual indifferent. In each parameter region, given the distribution of C_i , the indifference condition obtained will determine the share of informed individual.

Lemma 6. *Given $p \in (0, 1)$, $q \in (0, 1)$ and $T \in (0, 1)$, the individual indifferent between acquiring news or remaining uninformed - if he exists - is identified by:*

- (CASE A) $C_I = p(1 - p)q(1 + T) - P_A$ if $p < \frac{1}{2}$
- (CASE B) $C_I = p[q(1 - p) + T(p - 2)] + T - P_A$ if $p > \frac{1}{2}$ and if $(1 - p) > (1 - q)p$
- (CASE C) $C_I = p(1 - p)q(1 - T) - P_A$ if $p > \frac{1}{2}$ and if $(1 - p) < (1 - q)p$

[see Proof 3.6.5 in the Appendix]

The existence of C_I depends on the equilibrium price P_A , determined endogenously by the profit maximization problem of media outlet. As it will be explained in the next section 3.3.2, the conditions ensuring the existence of C_I and a proper share of informed individuals depend on the degree of heterogeneity of information costs C_i . In the special case of information costs uniformly distributed over the unitary support $(0, 1)$, the optimal price guarantees the existence of a positive share of informed individuals without assuming further conditions. For a complete discussion see Extra Appendix.

3.3.2 Media Outlets

Media outlets process information in news that can be purchased by voters. Outlets receive a signal s about Incumbent's type before the electoral stage and they make a report about this signal to informed voters. At this stage, media outlets should decide their report strategy (r) and their access price (P_A) in order to maximize both market-profits and revenues coming from the Incumbent. However, in the benchmark model, I focus just on the decision about prices, ruling out the possibility of capture by government. Media outlets follow a strategy of *truthful reporting* of signals ($s = r$) and they receive just market-profits (audience-related revenues). The demand of news is derived endogenously as the share of informed individuals.²³ Individuals always considers media as a neutral filter of information about the Incumbent: this means that they are not aware of the possibility of corruption and news distortion but just of the possibility of mistake.

The framework considered is a non-competitive market for news with one monopolist media outlet. I first derive the demand for news and the maximization strategy of the outlet. In the process of producing news the outlet does not incur in costs of production and its activity is just to report signals received about Incumbent's type: the monopolist media outlet maximizes profits by setting an optimal access price to its contents. Secondly, I consider the effects of changes in priors, quality of signals and heterogeneity of individuals on equilibrium quantities and prices. Finally I consider a more specific case with a distribution of costs on a unitary support.

Demand for news and Profit's maximization

In the previous section, I obtained the cost C_I identifying the individual indifferent between acquiring information or remaining uninformed. Given C_I , it is possible to identify voters willing to get informed as those individuals with a cost inferior to C_I . The share of informed individuals is therefore computed as the cumulative density function of C_I . I assume C_i to be uniformly distributed on a positive support, with a minimum cost of information a and a maximum cost b .²⁴ Each cost C_i has a density of $\frac{1}{b-a}$. The extent of the support ($b - a$) can be seen as the degree of heterogeneity among individuals. By assuming voters to consume just one piece of news, I can consider the share of informed individuals as the demand for news. If in all cases it exists a cost C_I associated to the individual indifferent between acquiring information or remaining uninformed, I can express the demand for news as the cumulative density function $CDF(C_I)$.

²³By assuming that each informed individual can "consume" just one piece of news, the number of individuals willing to acquire information (signal's report) can be a proxy for the demand for news, given price P_A , their information costs C_i and the quality of news q .

²⁴ $C_i \sim U(a, b)$ with $a \geq 0$ and $b > a$.

Lemma 7. *(Demand for news)*

Given $p \in (0, 1)$, $q \in (0, 1)$, $T \in (0, 1)$ and positive heterogeneous costs of information distributed uniformly, the demand for news faced by the monopolistic media outlet is:

- (CASE A) demand = $\frac{p(1-p)q(1+T)-P_A-a}{b-a}$ if $p < \frac{1}{2}$
- (CASE B) demand = $\frac{p[q(1-p)+T(p-2)]+T-P_A-a}{b-a}$ if $p > \frac{1}{2}$ and if $(1-p) > (1-q)p$
- (CASE C) demand = $\frac{p(1-p)q(1-T)-P_A-a}{b-a}$ if $p > \frac{1}{2}$ and if $(1-p) < (1-q)p$

In all cases demand for news is increasing in the quality of signal q and decreasing in access price P_A . Moreover, demand depends on the degree of heterogeneity $(b-a)$.²⁵

In order to ensure that demand is positive - which means to have proper shares of informed and uninformed individuals - I have to impose conditions on the lower bound of information costs a and a limit on prices.²⁶

By now I consider the maximization of audience-related revenues by the monopolist media, given the demand for news obtained in Lemma 7.

In order to maximize its market profits, the monopolist set an optimal access price P_A^* to its content which is a function of relevant parameters and degree of heterogeneity as stated in the following proposition.

Proposition 22. *(Optimal price and optimal quantity)*

Given $p \in (0, 1)$, $q \in (0, 1)$, $T \in (0, 1)$ and positive heterogeneous costs of information $C_i \sim U(a, b)$, the monopolistic media outlet fixes the profit-maximizing price P_A^* to:

- (CASE A) $P_A^* = \frac{p(1-p)q(1+T)-a}{2}$ if $p < \frac{1}{2}$
- (CASE B) $P_A^* = \frac{p[q(1-p)+T(p-2)]+T-a}{2}$ if $p > \frac{1}{2}$ and if $(1-p) > (1-q)p$
- (CASE C) $P_A^* = \frac{p(1-p)q(1-T)-a}{2}$ if $p > \frac{1}{2}$ and if $(1-p) < (1-q)p$

[see proof 3.6.6 in Appendix]

In all cases prices are increasing in the quality of the signal q and they take into account the probability of states of nature and the minimum cost of information a . Profits and optimal quantities are affected in the same way with respect to the quality measure q and in addition they take into account the degree of heterogeneity - measured by $(b-a)$ - of individuals.²⁷ Prices, quantities and profits are positive if some requirements are met: in order to obtain an informed share included between 0 and 1, optimal prices must satisfy the conditions stated for news' demand.²⁸ In particular, restrictions are imposed on the support of information costs' distribution (a and b) by requiring a minimum degree of heterogeneity among voters.

Profits' maximization with $C_i \sim U(0, 1)$.

So far I considered a general situation of a unit mass of individuals heterogeneous which are distributed uniformly over a generic positive support (a, b) . As previously stated, this set-up requires further conditions on a and b in order to guarantee that the demand for news is positive and that a share of uninformed individuals exists.²⁹ These restrictions complicate the analysis by increasing the number

²⁵For a complete description of these effects see Extra Appendix.

²⁶For a detailed analysis of these restrictions see Extra Appendix.

²⁷For a complete description of these effects see Extra Appendix.

²⁸See Extra appendix.

²⁹See Extra appendix.

of conditions required without adding any important insight. In order to simplify the analysis I consider a special case: a uniform distribution with a unitary support. In this setting it means to consider a uniform distribution of information costs $C_i \sim U(a, b)$ with $a = 0$ and $b = 1$.

Lemma 8. (*Modification of proposition 22*)

Given $p \in (0, 1)$, $q \in (0, 1)$, $T \in (0, 1)$ and heterogeneous costs of information $C_i \sim U(0, 1)$, the monopolistic media outlet obtains positive profits by fixing the profit-maximizing price P_A^* to:

- (CASE A) $P_A^* = \frac{p(1-p)q(1+T)}{2}$ if $p < \frac{1}{2}$
- (CASE B) $P_A^* = \frac{p[q(1-p)+T(p-2)]+T}{2}$ if $p > \frac{1}{2}$ and if $(1-p) > (1-q)p$
- (CASE C) $P_A^* = \frac{p(1-p)q(1-T)}{2}$ if $p > \frac{1}{2}$ and if $(1-p) < (1-q)p$

This simplification does not change results of previous stages since it just affects the computation of optimal prices and profits in the media's stage. With this distribution, the level of heterogeneity is sufficient to obtain, after maximization, an informed share $S_I \in (0, 1)$ and an uninformed share $S_U = 1 - S_I \in (0, 1)$ in all cases and for every $p \in (0, 1)$, $q \in (0, 1)$ and $T \in (0, 1)$.³⁰

3.3.3 Politicians

Having defined equilibrium strategies for voters and media, it is possible to determine the expected shares of votes for the two candidates. In particular, ex-ante expected shares of votes and ex-post share for the Incumbent are determined after having observed the signal. In the simplified version of the model both the Incumbent and the Opponent can't modify their type and they can't interfere with the provision of news. Since they are unable to exert effort in order to improve their probability of victory, they act as *passive agents*. Once the possibility of media capture is introduced, Incumbent's objective will be re-election and he will *actively* try to extract the maximum tangible rent for himself. Individuals always considers media as a neutral filter of information about the Incumbent: this means that they are not aware of the possibility of corruption and news distortion but just of the possibility of mistake.

Expected shares of votes from informed group and uninformed group

In a deterministic retrospective voting model it is possible to compute the probability of victory of one candidate by "counting" how many voters prefer him to his challengers. In this model, the number of votes for each politician it is determined by considering optimal moves in the electoral stage. Symmetrically with the previous section, I keep the distinction between uninformed individuals and informed ones and I derive for each candidate his share of expected votes ex-ante and ex-post.

Lemma 9. (*Expected votes from uninformed share*³¹) *From the uninformed group, the Incumbent and the Opponent expect the same number of votes, namely half of the uninformed share:*

$$\frac{S_U}{2} = \frac{1 - S_I}{2} \quad (3.3.3)$$

³⁰See Extra appendix.

³¹In this case ex-ante and ex-post expected shares of votes coincide. These votes are expected due to the fact that the composition (in terms of dimension of the groups) depends on priors.

Uninformed individuals obtain the same expected utility from the Incumbent and from the Opponent.³² In absence of partisan consideration different from expected utility (no ideological preferences or party affiliation), uninformed individuals are assumed to vote using a mixed strategy, choosing the Incumbent in the 50% of cases and the Opponent in the remaining 50%. On the basis of this behaviour, each candidate will obtain half of the votes of the uninformed group.

Differently, informed individuals receive from media additional information on the realization of Incumbent's type and they condition their electoral choice on news. If they receive bad news ($r = b$) they vote for the Opponent; if instead they don't receive bad news ($r = \emptyset$) they vote for the Incumbent.³³

Lemma 10. (*Ex-ante Expected votes from informed share*³⁴) *The Incumbent and the Opponent have an expected share of votes from the informed group that depends on news :*

$$\text{Opponent's share} = S_I \times pq \quad (3.3.4)$$

$$\text{Incumbent's share} = S_I \times [p(1 - q) + (1 - p)] \quad (3.3.5)$$

[See Proof 3.6.7 in the Appendix]

Expected shares of votes

By considering both votes coming from the uninformed share and those from the informed one, it is possible to assess the expected number of votes for each candidate. These ex-ante expected shares of votes are obviously functions of the composition of the electorate (S_I and S_U), the probability of negative event and the quality of news. In a framework of truthful reporting media and passive politicians, there is possibility for both candidates to win the office. In Lemma 11 and Proposition 23, I assess under which conditions the expected share of one candidate exceeds the 50%+1 of votes - namely when it is greater than $\frac{1}{2}$ - making him the expected winner. I also compute ex-post shares of votes, which will be used in the next section.

Lemma 11. (*Ex-ante Expected Votes*)

Each candidate competing in the electoral arena has an expected share of votes which depends on the probability of negative event (p), on the quality of signals (q) and on the composition of the electorate (S_I and S_U). These expected shares of votes are, respectively:

$$V_O = \frac{1 - S_I}{2} + S_I \times pq \quad (3.3.6)$$

$$V_I = \frac{1 - S_I}{2} + S_I \times [p(1 - q) + (1 - p)] \quad (3.3.7)$$

The difference between votes expected by the Incumbent (V_I) and those by the Opponent (V_O) lays in the share coming from informed individuals. In this sense the informed individuals become *pivotal*. This is due to the fact that the uninformed group always vote half for each candidate. The informed

³²The two candidates have the same prior probabilities on types and uninformed individuals condition their private actions just on the probability of negative event.

³³This electoral behaviour has been derived as equilibrium in section 3.3.1.

³⁴Ex-post expected votes will differ in this case, since Incumbents know the realization of signals. If media receive a signal $s = \emptyset$, in case of truthful reporting, he expect to be voted by the whole informed group; instead, if $s = b$ he expect to obtain no votes from the informed group.

individuals instead condition their electoral choice on news and their votes are influenced by changes in types' distribution and quality of signals.

If the probability p of bad type increases (ceteris paribus) it affects both the share of votes going to the Incumbent and those received by the Opponent: pq and $p(1 - q)$ increases but $(1 - p)$ decreases, making the overall effect on Incumbent's votes depending on which effect prevails.

If the reduction in $(1 - p)$ is stronger than the increment of pq , an increase of negative state's probability implies an increase of votes received by the Opponent and reduction of those received by the Incumbent. A rise in signal's quality (ceteris paribus) benefits the Opponent since pq increases and $p(1 - q)$ decreases. Looking at each different cases, it is possible to disentangle this ambiguity and to assess which effect prevails.

Proposition 23.

The Incumbent is expected to win iff $pq < \frac{1}{2}$: a sufficient condition is that $p < 1/2$, while $p > 1/2$ and $q > 1/2$ are sufficient to expect the victory of the Opponent .

[see Proof 3.6.8 in the Appendix]

Proposition 23 states under which conditions the Incumbent and the Opponent are expected to win and which are the effects of better signals. It is fundamental to notice that the quality of signals has a “double” effect: an increase in q increments Opponent's expected votes and increase the range of parameter supporting the case in which individuals match their private actions to news received (Case B). Quality intervenes both on winner's selection and on voters' behaviour. A sufficiently “high” q ($q > \frac{1}{2}$) increases Opponent's probability of victory since it makes more likely to receive a negative news about the Incumbent. This becomes crucial when the negative state is more likely to occur ($p > \frac{1}{2}$). Moreover, q reduces the range of p (it is required a higher p) supporting the case of non-matching between report and private actions (case C). With high-quality news, individuals choose an indiscriminate behaviour $a = b$ only if the negative event is more likely than the good one.

Notice that the ex-post share of votes are deterministic: if $s = b$ the Opponent receives votes from the informed group and half from the uninformed group, expecting a victory; the opposite hold in case of $s = \emptyset$.

3.4 Media Capture: Incentives

What happens when the possibility of media capture is introduced? Does the Incumbent have any incentive to spend resources in corrupting media? When a media should accept bribing and when refuse it? There exist a trade-off between audience-related revenues and policy-related revenues? All this question are fundamental in order to assess under which conditions media capture may arise. The present section deals with the possibility for the Incumbent of offering media a compensation for silencing negative signals. I first analyse what happens to expected shares of votes when the monopolist outlet is captured, in order assess whether or not this may change chances of victory for the Incumbent. Then, I check if the Incumbent has the incentives to invest part of the rent in corruption even in presence of a possibility of and for which level of bribing media silences negative signals. Recall that Individuals always considers media as a neutral filter of information about the Incumbent: this means that they are not aware of the possibility of corruption and news distortion but just of the possibility of mistake.

3.4.1 Expected Shares of Votes

What happens to expected shares of votes when the monopolist media is captured? Having the only existing media outlet corrupted means that the only report is $r = \emptyset$. This implies that all informed individuals vote for the Incumbent:

$$V_I = \frac{1}{2} + \frac{1}{2}S_I \quad (3.4.1)$$

In this case, the Incumbent wins elections with certainty if at least one voter is informed. Instead, the Opponent loses for sure, since he expects to receive just half of the votes of uninformed individuals:

$$V_O = \frac{1}{2} - \frac{1}{2}S_I \quad (3.4.2)$$

3.4.2 Incentive to Capture

Obviously, the Incumbent has the incentive to corrupt media if there are some informed voters and if media receive a negative signal. However, when is it profitable for him? Benefits from corruption have to overcome costs, that is the rent from holding the office R has to be greater than the necessary amount of bribes:

$$\begin{aligned} ER &> \text{bribes} \\ ER &> \sum_{j=1}^n y_j \end{aligned} \quad (3.4.3)$$

In addition to the amount of bribes paid the Incumbent may run into other costs of corruption, namely the possibility of being detected. If a politician is caught corrupting and silencing media, it is reasonable to assume that he will incur in some forms of punishment. Here the punishment is the removal from the office and the loss of all benefits. The more politicians corrupt media, the more evidence is possible to be collected against them. I call γ the probability of detection and I assume it to be an increasing function of the number of media captured n_c : $\gamma = 0$ if $n_c = 0$ and $\gamma \rightarrow 1$ as $n_c \rightarrow \infty$. This implies that costs of corruption are increasing in the number of media outlets.

Hence, the Incumbent faces a trade-off between increasing his probability of victory by corrupting media and decreasing the probability of being detected.

$$\begin{aligned} R * \text{prob}(V_I > \frac{1}{2}) - \sum_{j=1}^n y_j - R\gamma &> 0 \\ R * (p_{\text{victory}} - \gamma) &> \sum_{j=1}^n y_j \end{aligned} \quad (3.4.4)$$

where $\text{prob}(V_I > \frac{1}{2}) = \text{probability of victory} = p_{\text{victory}}(p, q, n_c, s)$.

In case of monopoly

$$\begin{aligned} R * \text{prob}(V_I > \frac{1}{2}) - y - R\gamma &> 0 \\ R(p_{\text{victory}} - \gamma) &> y \end{aligned} \quad (3.4.5)$$

When media outlets accept bribes? In this framework, individuals always consider media as a truthful reporter; moreover they don't have any preference for the content of the report. That is, if they decide to buy the news they will do it both if it is a "bad" or a "good" news. An alternative intuition for this kind of behavior is to assume that individuals buy news before knowing the content (eg. subscriptions to newspapers). Hence, individuals don't make any distinction between news and the demand for information is not affected by the kind of report. Outlets accept to be captured for any value greater than zero since there is no real trade-off between market profits and policy-related revenues (bribes).

$$y_j > 0 \quad (3.4.6)$$

If the only condition on bribes is non negativity, the equilibrium strategy for the Incumbent is to set a bribe enough close to zero in order to preserve his rent. Hence the Incumbent should corrupt an optimal number of media n_c^* , sufficient to have

$$R * (p(n_c^*) - \gamma(n_c^*)) \gtrsim 0 \quad (3.4.7)$$

$$p(n_c^*) > \gamma(n_c^*) \quad (3.4.8)$$

In case of monopoly it is always the case that $p_{victory} > \gamma$ in case of media capture. This pessimistic result predicts media capture under monopoly in any situation different from the case $p < \frac{1}{2}$: when the positive event is more likely than the negative one, the Incumbent expects to win even if media are not silenced. In this case the risk of incurring in the punishment is not worth it.

When the number of media outlet increases it is possible to obtain an intermediate result where the Incumbent corrupts a sufficient number of media in order to be re-elected and not detected. For the time being I can only assess that there is always room for media capture and that as the number of outlets increases there is no incentive to corrupt the whole market. A further analysis on the shape of $p_{victory}$ and of γ should tell us if there exist situations under which it does not exist a n_c^* such that $p(n_c^*) > \gamma(n_c^*)$.

3.5 Conclusions

The model developed so far produces a number of predictions on the relationship between the media industry, the electorate and political candidates.

The main conclusion is that information is a fundamental element for electoral choices and that any attempt to increase quality of news and to reduce information's costs can have positive effects on the selection of politicians. Quality intervenes both on winner's selection and on voters' behaviour. A "high" quality ($q > \frac{1}{2}$) increases Opponent's probability of victory in case of high probability of a bad Incumbent, since it makes more likely to receive a negative news. Moreover, with high-quality news, individuals condition more their actions on information and they choose an indiscriminate behaviour only if the negative event is very likely.

Regarding the possibility of media capture, my result both confirms and contradicts the one obtained by Beasley and Prat (2006). They found that "*media pluralism provides effective protection against capture*" since incentives to capture the media market decrease as the number of outlets increases. Indeed they assume individuals to prefer and buy only informative news ($r = b$)³⁵ and that once reported, news become public. The conclusion is that to make capture effective an Incumbent has to bribe the whole market. Hence, as number of outlets increases also costs of corruption increase, making capture less likely. In this way they obtain a dichotomous result: the media industry is independent or it is capture.

Instead, I obtain an intermediate result: as the number of outlets increases, it exists an optimal level of corruption which does not coincide with the whole market. If the possibility of detection is included, the Incumbent faces a trade-off between increasing the probability of winning the office and being punished. Further analysis on the effect of capture on these two probabilities and on the effects of competition is needed.

Differently from what Besley and Prat (2006) state, there is always incentive to corruption and media market is never completely independent. This pessimistic result predicts complete media capture under monopoly in any situation different from the case of low probability of negative event ($p < \frac{1}{2}$).

Therefore, the possibility of media capture is an important issue we should worry about. Since it is robust to increases in competition, it is fundamental to induce media outlets to privilege accuracy over remunerations from news's distortion in order to reduce incentives to corruption.

³⁵Media outlets face a trade-off between markets profits and policy related revenues.

The analysis developed here is simple, and much remains to be done to obtain a complete picture of the issues involved.

Bibliography

- [1] Alberto Alesina, Alberto (1988) “Credibility and policy convergence in a two-party system with rational voters”, *American Economic Review*, 78(4):796805, September.
- [2] Baron, David P. (2006) “Persistent media bias”, *Journal of Public Economics*, 90:1 36.
- [3] Battaglion, Maria Rosa and Vaglio, Alessandro (2012) “The market for news: a demand-oriented analysis”, *Economia politica*, (1):81110.
- [4] Besley, Timothy (2006) *Principled agents? The political economy of good government*, Oxford University Press, Oxford; New York.
- [5] Besley, Timothy and Ghatak, Maitreesh (2005) “Competition and incentives with motivated agents”, *American Economic Review*, 95(3):616636.
- [6] Besley, Timothy and Prat, Andrea (2006) “Handcuff for the grabbing hand? Media capture and Government Accountability”, *American Economic Review*, 96(3):720736, June.
- [7] Blasco, Andrea and Sobbrío, Francesco (2012) “Competition and commercial media bias”, *Telecommunications Policy*, 36(5):434 447.
- [8] Brunetti, Aymo and Weder, Beatrice (2003) “A free press is bad news for corruption”, *Journal of Public Economics*, 87(7-8):18011824, August.
- [9] Steven Callander. Political motivations. *Review of Economic Studies*, 75(3):671697, 2008.
- [10] Calvert, Randall L. (1985) “Robustness of the multidimensional voting model: Candidate motivations, uncertainty, and convergence”, *American Journal of Political Science*, 29(1):pp. 6995.
- [11] Chan, Jimmy and Suen, Wing (2008) “A spatial theory of news consumption and electoral competition”, *Review of Economic Studies*, 75(3):699728, 07.
- [12] Corneo, Giacomo (2006) “Media capture in a democracy: The role of wealth concentration”, *Journal of Public Economics*, 90(1-2):3758, January.
- [13] Djankov, Simeon and Caralee, McLiesh and Nenova, Tatiana and Shleifer, Andrei (2003) “Who owns the media?”, *Journal of Law and Economics*, 46(2):34181, October.
- [14] Downs, Anthony (1957) “An economic theory of political action in a democracy”, *Journal of Political Economy*, 65:135.
- [15] Dyck, Alexander and Volchkova, Natalya and Zingales, Luigi (2008) “The corporate governance role of the media: Evidence from Russia”. *Journal of Finance*, 63(3):10931135, 06.
- [16] Dyck, Alexander and Zingales, Luigi (2004) “Private benefits of control: An international comparison”, *Journal of Finance*, 59(2):537600, 04.

- [17] Gambaro, Marco and Puglisi, Riccardo (2010) “What do ads buy? daily coverage of listed companies on the italian press”, RSCAS Working Papers 2010/26, European University Institute, January.
- [18] Gentzkow, Matthew and Shapiro, Jesse M. (2006) “Media bias and reputation”, *Journal of Political Economy*, 114(2):280316, April.
- [19] Hotelling, Harold (1929) “Stability in competition”, *The Economic Journal*, 39(153):pp. 4157.
- [20] Mcmillan, John and Zoido, Pablo (2004) “How to subvert democracy: Montesinos in peru” *Journal of Economic Perspectives*, 18(4):6992, Fall.
- [21] Mullainathan, Sendhil and Shleifer, Andrei (2005) “The market for news”, *American Economic Review*, 95(4):10311053, September.
- [22] Persson, Torsten and Tabellini, Guido (2000) *Political Economics: Explaining Economic Policy*, volume 1 of MIT Press Books. The MIT Press.
- [23] Petrova, Maria (2008) “Inequality and media capture”, *Journal of Public Economics*, 92(1-2):183212, February.
- [24] Petrova, Maria (2009) “Newspapers and parties: How advertising revenues created an independent press”, Working Papers w0131, Center for Economic and Financial Research (CEFIR), August.
- [25] Prat, Andrea and Strömberg, David (2011) “The political economy of mass media”, CEPR Discussion Papers 8246, C.E.P.R. Discussion Papers, February.
- [26] Sobbrío, Francesco (2014) “Citizen-editors’ endogenous information acquisition and news accuracy”, *Journal of Public Economics*, 113:4353.
- [27] Sobbrío, Francesco (2014) *The Political Economy of News Media: Theory, Evidence and Open Issues*, Edward Elgar Press.
- [28] Di Tella, Rafael and Franceschelli, Ignacio (2011) “Government advertising and media coverage of corruption scandals”, *American Economic Journal: Applied Economics*, 3(4):11951, October.
- [29] Wittman, Donald (1977) “Candidates with policy preferences: A dynamic model”, *Journal of Economic Theory*, 14(1):180189, February.
- [30] Wittman, Donald (1983) “Candidate motivation: A synthesis of alternative theories”, *The American Political Science Review*, 77(1):pp. 142157.

Appendix

3.6 Proofs of lemmas and propositions

3.6.1 Proof of proposition 20

The proof is twofold. First I compute expected utilities for informed voters given individual actions. Secondly I look for equilibrium strategies. Information received about the Incumbent is incorporated in the update of types probability: in case of informed individuals I use posteriors for computing the expected utility from Incumbent. In the expected utilities from the Opponent I use priors.

1. If the report is $s = b$ posteriors are:

$$pr(b|s = b) = \frac{pr(s = b|b) \times pr(b)}{pr(s = b)} = 1 \quad (3.6.1)$$

$$pr(g|s = b) = \frac{pr(s = b|g) \times pr(g)}{pr(s = b)} = 0 \quad (3.6.2)$$

2. If the report is $s = \emptyset$ posteriors are:

$$\begin{aligned} pr(b|s = \emptyset) &= \frac{pr(s = \emptyset|b) \times pr(b)}{pr(s = \emptyset)} & (3.6.3) \\ &= \frac{(1 - q)p}{(1 - p) + (1 - q)p} \end{aligned}$$

$$\begin{aligned} pr(g|s = \emptyset) &= \frac{pr(s = \emptyset|g) \times pr(g)}{pr(s = \emptyset)} & (3.6.4) \\ &= \frac{1 - p}{(1 - p) + (1 - q)p} \end{aligned}$$

Expected utilities are computed for four different combinations :

1. In case of signal $s = b$ and action $a_i = b$, the expected utilities (I use posteriors 3.6.1 and 3.6.2) from the two candidates are respectively:

$$\begin{aligned} EU_I(a_i = b, s = b) &= & (3.6.5) \\ &= U(b) \times pr(b|s = b) + U(g) \times pr(g|s = b) + E[T \times I(a = b)] \\ &= T \end{aligned}$$

where $E[T \times I(a = b)] = T \times pr(b|s = b)$

$$\begin{aligned}
 EU_O(a_i = b, s = b) = EU_O(a_i = b) &= & (3.6.6) \\
 &= U(b) \times pr(b) + U(g) \times pr(g) + E[T \times I(a = b)] \\
 &= (1 - p) + Tp
 \end{aligned}$$

where $E[T \times I(a = b)] = T \times pr(b)$

2. In case of signal $s = b$ and action $a_i = g$, the expected utilities (I use posteriors 3.6.1 and 3.6.2) from the two candidates are respectively:

$$\begin{aligned}
 EU_I(a_i = g, s = b) &= & (3.6.7) \\
 &= U(b) \times pr(b|s = b) + U(g) \times pr(g|s = b) + E[T \times I(a = g)] \\
 &= 0
 \end{aligned}$$

where $E[T \times I(a = g)] = T \times pr(g|s = b)$

$$\begin{aligned}
 EU_O(a_i = g, s = b) = EU_O(a_i = g) &= & (3.6.8) \\
 &= U(b) \times pr(b) + U(g) \times pr(g) + E[T \times I(a = g)] \\
 &= (1 - p) + T(1 - p)
 \end{aligned}$$

where $E[T \times I(a = g)] = T \times pr(g)$

3. In case of signal $s = \emptyset$ and action $a_i = b$, the expected utilities (I use posteriors 3.6.3 and 3.6.4) from the two candidates are respectively:

$$\begin{aligned}
 EU_I(a_i = b, s = \emptyset) &= & (3.6.9) \\
 &= U(b) \times pr(b|s = \emptyset) + U(g) \times pr(g|s = \emptyset) + E[T \times I(a = b)] \\
 &= \frac{1 - p}{(1 - p) + (1 - q)p} + T \times \frac{(1 - q)p}{(1 - p) + (1 - q)p}
 \end{aligned}$$

where $E[T \times I(a = b)] = T \times pr(b|s = \emptyset)$

$$\begin{aligned}
 EU_O(a_i = b, s = \emptyset) = EU_O(a_i = b) &= U(b) \times pr(b) + U(g) \times pr(g) + E[T \times I(a = b)] & (3.6.10) \\
 &= (1 - p) + Tp
 \end{aligned}$$

where $E[T \times I(a = b)] = T \times pr(b)$

4. In case of signal $s = \emptyset$ and action $a_i = g$, the expected utilities from the two candidates are respectively:

$$\begin{aligned}
 EU_I(a_i = g, s = \emptyset) &= & (3.6.11) \\
 &= U(b) \times pr(b|s = \emptyset) + U(g) \times pr(g|s = \emptyset) + E[T \times I(a = g)] \\
 &= \frac{1-p}{(1-p) + (1-q)p} + T \times \frac{1-p}{(1-p) + (1-q)p}
 \end{aligned}$$

where $E[T \times I(a = g)] = T \times pr(g|s = \emptyset)$

$$\begin{aligned}
 EU_O(a_i = g, s = \emptyset) = EU_O(a_i = g) &= & (3.6.12) \\
 &= U(b) \times pr(b) + U(g) \times pr(g) + E[T \times I(a = g)] \\
 &= (1-p) + T(1-p)
 \end{aligned}$$

where $E[T \times I(a = g)] = T \times pr(g)$

Having computed the expected utilities in the different cases, I can now look for the equilibrium behaviour. Since there is no dominant strategies, I check under which conditions the following behaviour is an equilibrium strategy: if $s = \emptyset$, independently from the action chosen, it is optimal (the expected utility is greater) to choose the Incumbent; if $s = b$, independently from the action chosen, it is optimal (the expected utility is greater) to choose the Opponent.

To have this result it must be that, given the different parameters p , q and T :

$$\begin{aligned}
 EU_O(a_i = b) &> EU_I(a_i = b, s = b) \\
 (1-p) + Tp &> T \\
 T &< 1
 \end{aligned}$$

$$\begin{aligned}
 EU_O(a_i = g) &> EU_I(a_i = g, s = b) \\
 (1-p) + T(1-p) &> 0
 \end{aligned}$$

which is satisfied if $T > -1$

$$\begin{aligned}
 EU_I(a_i = b, s = \emptyset) &> EU_O(a_i = b) \\
 \frac{1-p}{(1-p) + (1-q)p} + T \times \frac{(1-q)p}{(1-p) + (1-q)p} &> (1-p) + Tp \\
 \frac{(1-p) + T(p-pq) - (1-pq)[(1-p) + Tp]}{1-pq} &> 0
 \end{aligned}$$

if I exclude $p = 0$, $p = 1$, $q = 0$ and $q = 1$, I impose that the denominator is > 0 . The numerator is positive if $T < 0$ or if $T > 0$ and $T < 1$. Hence the conditions ensuring $EU_O(a_i = b) > EU_I(a_i = b, s = b)$ are $T < 1$, $p \in (0, 1)$ and $q \in (0, 1)$.

$$\begin{aligned}
EU_I(a_i = g, s = \emptyset) &> EU_O(a_i = g) \\
\frac{1-p}{(1-p) + (1-q)p} + T \times \frac{1-p}{(1-p) + (1-q)p} &> (1-p) + T(1-p) \\
\frac{1}{(1-p) + (1-q)p} [(1-p) + T(1-p)] &> (1-p) + T(1-p)
\end{aligned}$$

if I exclude $q = 0$ and $p = 0$, then $\frac{1}{(1-p) + (1-q)p} > 1$ and the condition is satisfied.

To recap, the conditions required are:

$$p \in (0, 1) \quad (3.6.13)$$

$$q \in (0, 1) \quad (3.6.14)$$

$$T \in (-1, 1) \quad (3.6.15)$$

3.6.2 Proof of proposition 21

Moving to the action stage, I look for equilibrium moves with regards to the choice of private action a_i . It is important to recall that these actions are chosen given equilibrium electoral choices (*Proposition 20*). Hence all condition from the electoral stage hold. Informed individuals correctly anticipate who is going to win the election, namely the candidate they choose. Hence, in the evaluation of expected utilities for an informed individual, I use posteriors propabilities just when $s = \emptyset$, since voters are choosing the Incumbent. Instead, when $s = b$, individuals choose the Opponent and priors are needed in computing the expected utility. To identify equilibrium actions, I compare expected utilities from each candidate, given signals and electoral choices.

When the report is $s = b$, all informed individuals will choose to vote for the Opponent. The expected utilities deriving from choosing $a = g$ and $a = b$ are respectively:

$$EU_O(a = g) = (1-p) + T(1-p) \quad (3.6.16)$$

$$EU_O(a = b) = (1-p) + Tp \quad (3.6.17)$$

By comparing these two expected utilities, it is clear that it doesn't exist a choice giving an expected utilities that is always greater. However under some conditions, a private action is preferable to the other. If $T \in (0, 1)$, $EU_O(a = b) > EU_O(a = g)$ if $p > 1/2$ while $EU_O(a = b) < EU_O(a = g)$ if $p < 1/2$.

If $T \in (-1, 0)$ the opposite result holds. I restrict the analysis on the more realistic case of a positive impact of private action, $T > 0$: if $p > 1/2$ it is optimal to choose $a = b$ if $s = b$; if $p < 1/2$ it is optimal to choose $a = g$ if $s = b$.

If instead the report is $s = \emptyset$, all informed individuals will choose to vote for the Incumbent. The expected utilities deriving from choosing $a = g$ and $a = b$ are respectively:

$$EU_I(a = g) = \frac{1-p}{(1-q)p + (1-p)} + T \frac{1-p}{(1-q)p + (1-p)} \quad (3.6.18)$$

$$EU_I(a = b) = \frac{1-p}{(1-q)p + (1-p)} + T \frac{p(1-q)}{(1-q)p + (1-p)} \quad (3.6.19)$$

To state which expected utility is bigger, I compare the second element of the right side of these two equation. If $T \in (0, 1)$, the sign of the inequality depends on p and q . Again, the threshold value is $p = 1/2$.

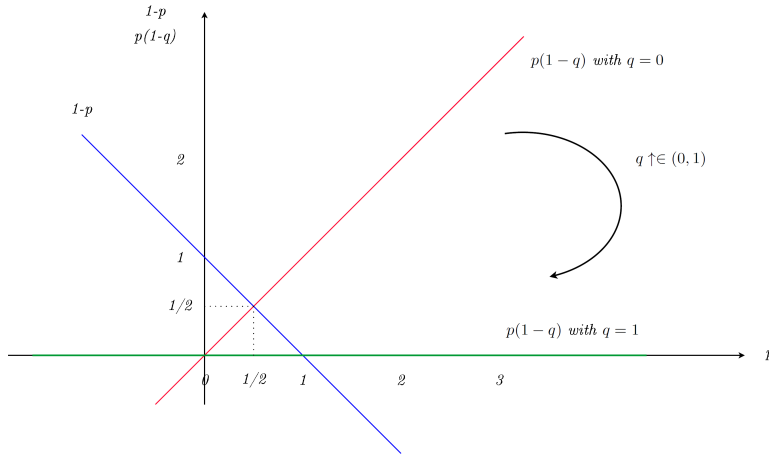

If $p < 1/2$ then $\forall q \in (0, 1)$ we have $(1 - p) > p(1 - q)$, implying $EU_I(a = g) > EU_I(a = b)$; whereas if $p > 1/2$, also q matters

$$\begin{aligned}
 & \text{if} \\
 & (1 - p) > p(1 - q) \\
 \Rightarrow & EU_I(a = g) > EU_I(a = b) \\
 & \text{if} \\
 & (1 - p) < p(1 - q) \\
 \Rightarrow & EU_I(a = g) < EU_I(a = b)
 \end{aligned}$$

If $T \in (-1, 0)$ the opposite result holds.

Therefore the existence of an optimal private action on the sign of T and on the size of p and, in some cases, on the level of q . This helps in mapping some regions of parameters. I focus on the more realistic condition that $T \in (0, 1)$, obtaining the following results:

- if $p > 1/2$ (HIGH PROB. OF NEGATIVE STATE) and $(1 - p) < p(1 - q)$ it is dominant to choose $a = b$ if $s = \emptyset$ (and individual chooses Incumbent)
- if $p > 1/2$ (HIGH PROB. OF NEGATIVE STATE) and $(1 - p) > p(1 - q)$ it is dominant to choose $a = g$ if $s = \emptyset$ (and individual chooses Incumbent)
- if $p < 1/2$ (LOW PROB. OF NEGATIVE STATE) it is dominant to choose $a = g$ (for each value of $q \in (0, 1)$) if $s = \emptyset$ (and individual chooses Incumbent)

3.6.3 Proof of lemma 4

Given the results of Proposition 20 and Proposition 21, three parameter regions are identified for the case of informed individuals

- if $p < 1/2$ individuals choose $a = g$ whatever is the report (CASE A)
- if $p > 1/2$ and $(1 - p) > (1 - q)p$ individuals choose $a = b$ if $s = b$ and $a = g$ if $s = \emptyset$ (CASE B)
- if $p > 1/2$ and $(1 - p) < (1 - q)p$ individuals choose $a = b$ whatever is the signal (CASE C)

The reason for this additional case is that now the quality (q) of the signal matters if we have a high probability of negative state.

CASE A ($p < 1/2$)³⁶

Notice that in the branch $s = b$ informed individuals correctly anticipate the Opponent will win.

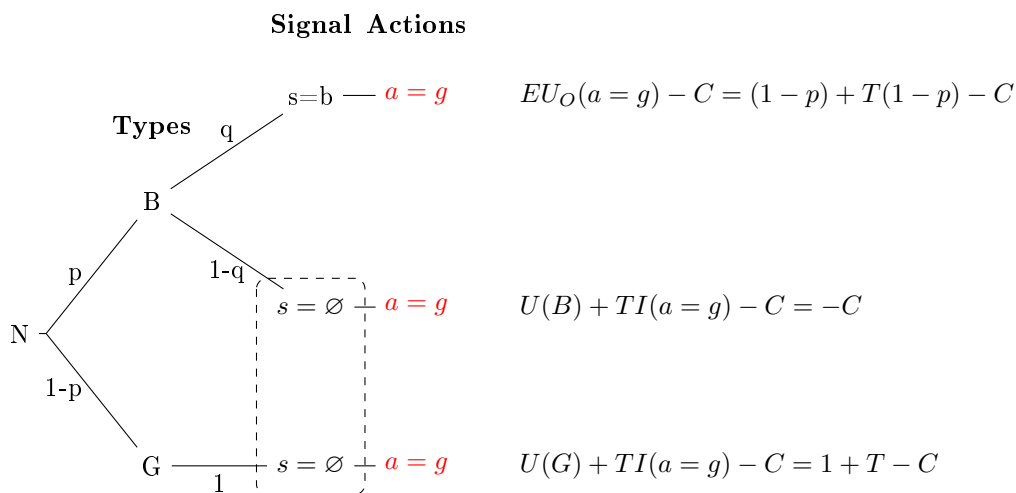

Figure 3.6.1: Case $p < 1/2$

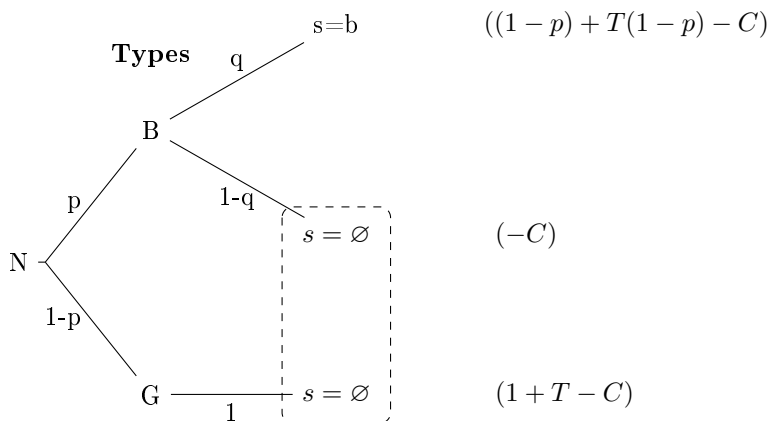

Figure 3.6.2: Case $p < 1/2$: pay-offs

³⁶ C summarizes both information cost C_i and access price P_A .

$$\begin{aligned}
 EU(a = g) &= pq[(1 - p) + T(1 - p) - C] + p(1 - q)[-C] + (1 - p)[1 + T - C] \quad (3.6.20) \\
 &= pq[(1 - p) + T(1 - p)] + (1 - p)[1 + T] - C
 \end{aligned}$$

CASE B ($p > 1/2$ and $(1 - p) > (1 - q)p$)

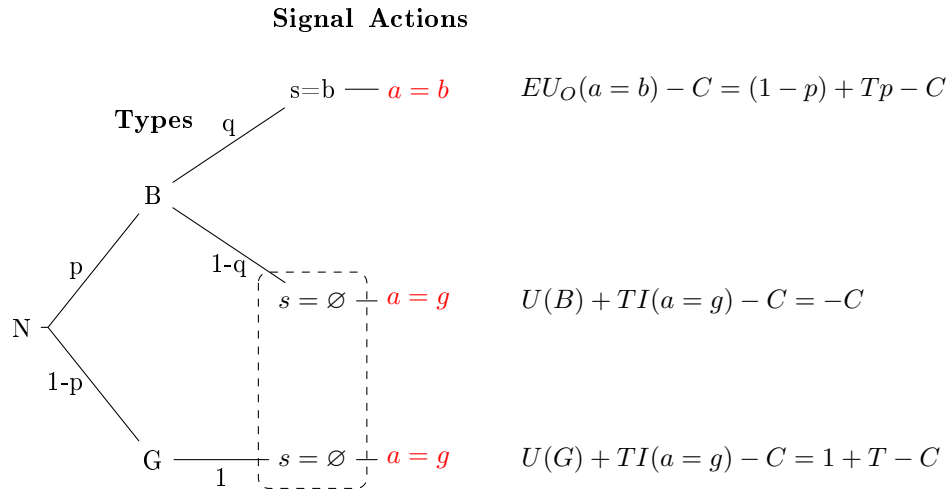

Figure 3.6.3: Case $p < 1/2$ e $(1 - p) > (1 - q)p$

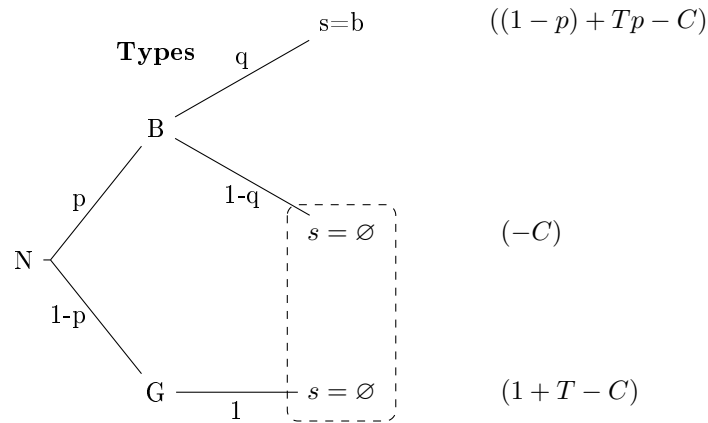

Figure 3.6.4: Case $p < 1/2$ e $(1 - p) > (1 - q)p$: pay-offs

$$\begin{aligned}
 EU &= pq[(1 - p) + Tp - C] + p(1 - q)[-C] + (1 - p)[1 + T - C] \quad (3.6.21) \\
 &= pq[(1 - p) + Tp] + (1 - p)[1 + T] - C
 \end{aligned}$$

CASE C ($p > 1/2$ and $(1 - p) < (1 - q)p$)

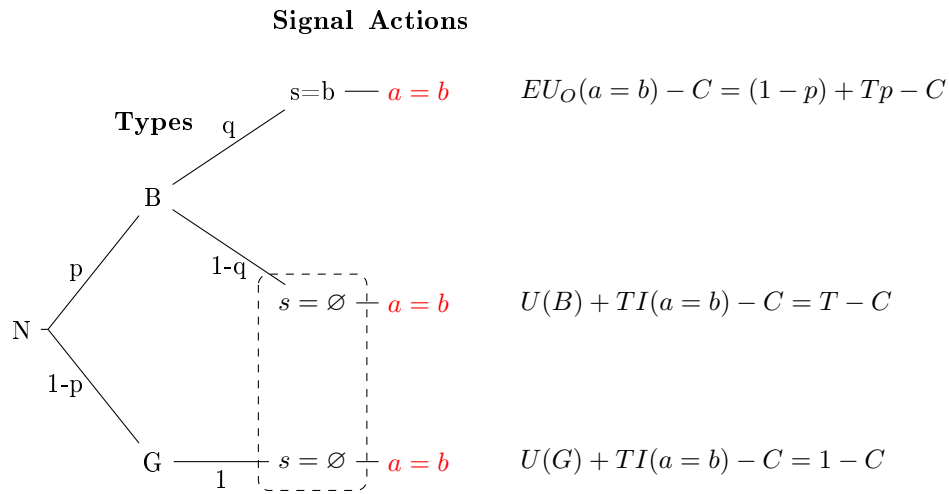

Figure 3.6.5: Case $p < 1/2$ e $(1 - p) > (1 - q)p$

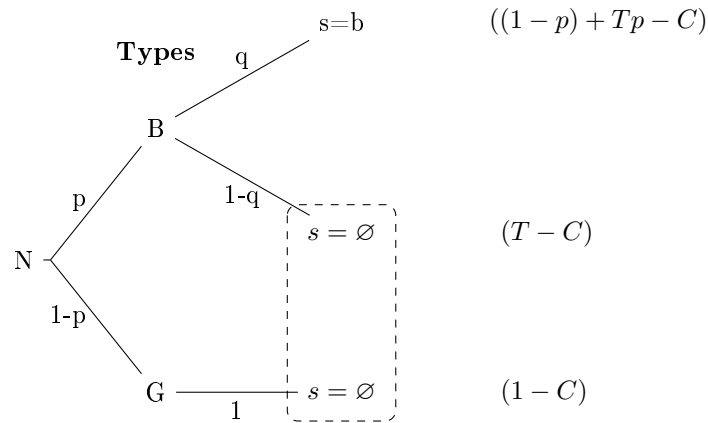

Figure 3.6.6: Case $p < 1/2$ e $(1 - p) > (1 - q)p$: pay-offs

$$\begin{aligned}
 EU(a = b) &= pq[(1 - p) + Tp - C] + p(1 - q)[T - C] + (1 - p)[1 - C] \\
 &= pq[(1 - p) + Tp] + p(1 - q)[T] + (1 - p) - C
 \end{aligned}
 \tag{3.6.22}$$

3.6.4 Proof of lemma 5

As stated in the previous section, given results from proposition 20 and proposition 21:

if $a = b$

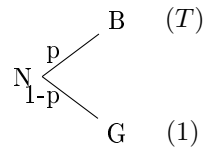

$$EU_I(a = b) = EU_O(a = b) = (1 - p) + Tp$$

if $a = g$

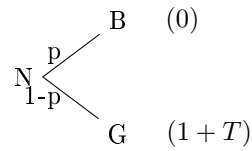

$$EU_I(a = g) = EU_O(a = g) = (1 - p) + T(1 - p)$$

obtaining the following equilibrium strategies:

- if $p > 1/2$ then $a = b \rightarrow EU = (1 - p) + Tp$
- if $p < 1/2$ then $a = g \rightarrow EU = (1 - p) + T(1 - p)$

3.6.5 Proof of lemma 6

In lemma 5 and lemma 4, we derived the following expected utilities for informed and uninformed individuals³⁷:

	Uninformed	Informed
$p < 1/2$	$(1 - p) + T(1 - p)$	$pq[(1 - p) + T(1 - p)] + (1 - p)[1 + T] - C$
$p > 1/2$ e $(1 - p) > (1 - q)p$	$(1 - p) + Tp$	$pq[(1 - p) + Tp] + (1 - p)[1 + T] - C$
$p > 1/2$ e $(1 - p) < (1 - q)p$	$(1 - p) + Tp$	$pq[(1 - p) + Tp] + p(1 - q)[T] + (1 - p) - C$

CASE A

$$\begin{array}{ll} \text{Expected utility informed} & \text{Expected utility uninformed} \\ pq[(1 - p) + T(1 - p)] + (1 - p)[1 + T] - C_i - P_A & (1 - p) + T(1 - p) \end{array}$$

The difference in expected pay-offs (gain from information) has to be bigger than costs (C_i and P_A), so that an individual finds profitable to acquire information

³⁷ C summarizes both access cost P_A and information cost C_i

$$\begin{aligned}
pq[(1-p) + T(1-p)] + (1-p)[1+T] - (1-p) - T(1-p) &\geq C_i + P_A \\
\underbrace{pq[(1-p) + T(1-p)]}_{>0} &\geq C_i + P_A
\end{aligned}$$

Since the left-hand side of the inequality is greater than zero, I am sure that exists at least one C_i which make convenient to get informed. Therefore, I can derive an indifference condition or a profitability condition:

$$p(1-p) \geq \frac{C_i + P_A}{q(1+T)}$$

The cost C_I corresponding to the indifferent voter is then

$$C_I = p(1-p)q(1+T) - P_A \quad (3.6.23)$$

CASE B

Expected utility informed	Expected utility uninformed
$pq[(1-p) + Tp] + (1-p)[1+T] - C_i - P_A$	$(1-p) + Tp$

In order to have information acquisition I need the difference in expected utilities (gain from information) to be greater than costs (C_i and P_A)

$$\begin{aligned}
pq[(1-p) + Tp] + (1-p)[1+T] - (1-p) - Tp &\geq C_i + P_A \\
pq - p^2q + T(1 + p^2q - 2p) &\geq C_i + P_A
\end{aligned}$$

The difference in expected utilities has to be greater than costs:

$$pq - p^2q + T(1 + p^2q - 2p) \geq C_i + P_A$$

It is possible to show that the negative parts of the LHS are compensated by the positive ones given the conditions of the case:

$$\begin{aligned}
p &\in \left(\frac{1}{2}, 1\right) \\
(1-p) &> (1-q)p
\end{aligned}$$

The last condition can be written as:

$$q > \frac{2p-1}{p}$$

Checking the sign of the LHS for the lowest value of q , that is for $q = \frac{2p-1}{p}$:

$$(1-T)(3p-2p^2) - (1-T) > 0$$

which is positive since $p \in (\frac{1}{2}, 1)$. Given that $\frac{\partial(pq-p^2q+T(1+p^2q-2p))}{\partial q} = p(Tp-p+1) > 0$, the sign of the inequality is the same for every $q > \frac{2p-1}{p}$.

Hence:

$$\underbrace{pq + T + (T-1)p^2q - 2pT}_{>0} \geq C_i + P_A$$

From this inequality I know that exists at least one cost making profitable to get informed and I can compute the indifference condition and the cost of the indifferent individual

$$C_I = p[q(1-p) + T(p-2)] + T - P_A \quad (3.6.24)$$

CASE C

Expected utility informed	Expected utility uninformed
$pq[(1-p) + Tp] + p(1-q)[T] + (1-p) - C_i - P_A$	$(1-p) + Tp$

The difference in expected utilities (gain from information) has to be greater than costs (C_i and P_A)

$$\begin{aligned} pq[(1-p) + Tp] + p(1-q)[T] + (1-p) - (1-p) - Tp &\geq C_i + P_A \\ pq[(1-p) - \underbrace{T}_{<1}(1-p)] &\geq C_i + P_A \\ \underbrace{\hspace{10em}}_{>0} & \end{aligned}$$

since the left-hand side is bigger than zero, it is possible to find at least one cost C_i making the individual to acquire news. The indifferent voter is identified by the cost

$$C_I = p(1-p)q(1-T) - P_A \quad (3.6.25)$$

3.6.6 Proof of proposition 22

Profit maximization requires the setting of an optimal price P_A^* , which is the only control variable for the media outlet. I show computations just for the first case.

In Case A ($p > \frac{1}{2}$), from lemma 7, the demand for news is given by

$$\begin{aligned} CDF(C_I) &= \frac{C_I - a}{b - a} \\ &= \frac{p(1-p)q(1+T) - P_A - a}{b - a} \end{aligned} \quad (3.6.26)$$

Audience related revenues are set as:

$$\begin{aligned} P_A \times CDF(C_I) &= P_A \times \left[\frac{C_I - a}{b - a} \right] \\ &= P_A \times \frac{p(1-p)q(1+T) - P_A - a}{b - a} \end{aligned} \quad (3.6.27)$$

Profit maximization problem gives the following results:

$$\begin{aligned} \max_{P_A} \left\{ P_A \times \frac{p(1-p)q(1+T) - P_A - a}{b - a} \right\} \\ \frac{\partial \{P_A \times CDF(C_I)\}}{\partial P_A} &= 0 \\ \frac{1}{b - a} \{ [p(1-p)q(1+T) - P_A - a] + P_A[-1] \} &= 0 \\ P_A^* &= \frac{p(1-p)q(1+T) - a}{2} \end{aligned} \quad (3.6.28)$$

The optimal quantity of news is obtained by substituting back P_A^* in the demand :

$$\begin{aligned} \text{demand}(P_A^*) &= CDF(C_I(P_A^*)) \\ &= \frac{p(1-p)q(1+T) - a}{2(b-a)} \end{aligned} \quad (3.6.29)$$

Maximization profits are:

$$\begin{aligned} \Pi^* &= P_A^* \times CDF(C_I(P_A^*)) \\ &= \frac{[p(1-p)q(1+T) - a]^2}{4(b-a)} \end{aligned} \quad (3.6.30)$$

Optimal prices, quantities and profits for Case B and Case C are derived in the same way.

Case	P_A^*	$\text{demand}(P_A^*)$	Π^*
Case A	$\frac{p(1-p)q(1+T)-a}{2}$	$\frac{p(1-p)q(1+T)-a}{2(b-a)}$	$\frac{[p(1-p)q(1+T)-a]^2}{4(b-a)}$
Case B	$\frac{p[q(1-p)+T(p-2)]+T-a}{2}$	$\frac{p[q(1-p)+T(p-2)]+T-a}{2(b-a)}$	$\frac{\{p[q(1-p)+T(p-2)]+T-a\}^2}{4(b-a)}$
Case C	$\frac{p(1-p)q(1-T)-a}{2}$	$\frac{p(1-p)q(1-T)-a}{2(b-a)}$	$\frac{[p(1-p)q(1-T)-a]^2}{4(b-a)}$

Table 3.6.1: Results from maximization

3.6.7 Proof of lemma 10

I compute the probability that an informed individual receives a certain kind of news and I use it to derive the shares of votes obtained by the two candidates as

$$\begin{aligned} \text{Incumbent's share:} & \quad S_I \times pr(s = \emptyset) \\ \text{Opponent's share:} & \quad S_I \times pr(s = b) \end{aligned}$$

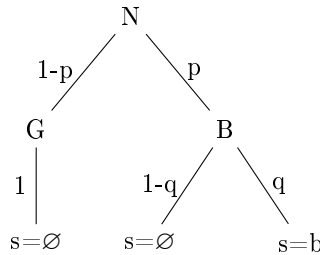

Figure 3.6.7: Signal's structure

Probabilities of each kind of news are

$$\begin{aligned} Pr(s = b) &= pq \\ Pr(s = \emptyset) &= p(1-q) + (1-p) \end{aligned}$$

Votes received by each candidate are:

$$\begin{aligned} \textit{Opponent} &= S_I \times Pr(s = b) \\ &= S_I \times pq \end{aligned}$$

$$\begin{aligned} \textit{Incumbent} &= S_I \times Pr(s = \emptyset) \\ &= S_I \times [p(1 - q) + (1 - p)] \end{aligned}$$

3.6.8 Proof of Proposition 23

A candidate wins if he obtains the 50%+1 of votes or more - that is if $V > \frac{1}{2}$.

From equation 3.3.6, the **Opponent** gets:

$$\begin{aligned} V_O &= \frac{1}{2} \times (1 - S_I) + S_I \times pq \\ &= \frac{1}{2} + S_I \times (pq - \frac{1}{2}) \end{aligned} \tag{3.6.31}$$

where S_I is the informed share. $S_I \in (0, 1)$ if conditions set in part 3.3.2 hold. $V_O > \frac{1}{2}$ only if $pq - \frac{1}{2}$ is positive, that is $pq > \frac{1}{2}$. when this is **not possible** if $p < \frac{1}{2}$.

From equation 3.3.7, the **Incumbent** gets:

$$\begin{aligned} V_I &= \frac{1}{2} \times (1 - S_I) + S_I \times [p(1 - q) + (1 - p)] \\ &= \frac{1}{2} + S_I \times [p(1 - q) + (1 - p) - \frac{1}{2}] \end{aligned} \tag{3.6.32}$$

$V_I > \frac{1}{2}$ only if $p(1 - q) + (1 - p) - \frac{1}{2} > 0$ that is if $p(1 - q) + (1 - p) > \frac{1}{2}$.

A sufficient condition to expect a victory of the Incumbent is that $p < \frac{1}{2}$. Otherwise, when $p > \frac{1}{2}$ it is sufficient to have $q < \frac{1}{2}$.

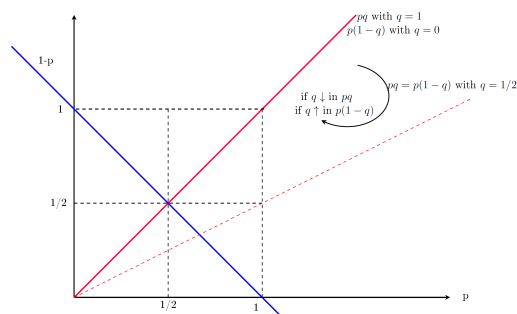

Figure 3.6.8:

Looking at fig. 3.6.8, it is possible to notice how a higher q increases the range of $p > \frac{1}{2}$ supporting case B (and reduces those supporting case C) where individuals set $a_i = b$ if $s = b$ and $a_i = g$ if $s = \emptyset$.

Extra Appendix

3.7 Conditions on shares

3.7.1 Informed Share and Uninformed Share

I use the share of informed individuals S_I as the demand for news faced by the monopolistic media outlet. The uninformed share is derived as the complementar share $S_U = 1 - S_I$.

Dimensions of both shares depend on the case considered and they are function of relevant parameters (p , q and T) and of the distribution (specifically, a and b) of information costs :

CASE	CASE'S CONDITIONS	INFORMED SHARE ³⁸
Case A	$p < \frac{1}{2}$	$S_I = \frac{p(1-p)q(1+T)-a}{2(b-a)}$
Case B	$p > \frac{1}{2}$ and $1 - p > p(1 - q)$	$S_I = \frac{p[q(1-p)+T(p-2)]+T-a}{2(b-a)}$
Case C	$p > \frac{1}{2}$ and $1 - p < p(1 - q)$	$S_I = \frac{p(1-p)q(1-T)-a}{2(b-a)}$

Conditions imposed so far do not ensure that shares are both included in $(0, 1)$: I check which conditions have to be imposed on parameters and prices - both before and after maximization - in order to have “proper” shares.

3.7.2 Checks on voters' shares

I need to ensure that

$$\begin{aligned} \text{informed share} &= S_I \in (0, 1) \\ \text{uninformed share} &= S_U \in (0, 1) \\ \text{by which} & S_U = 1 - S_I \end{aligned}$$

If shares depend just on information cost C_i there is no problem since these costs are assumed to be distributed uniformly with mass 1.

³⁸These are shares resulting from the maximization solution.

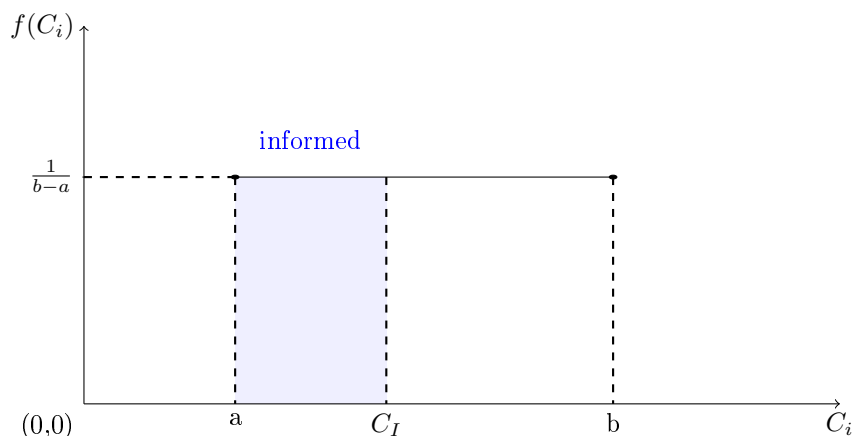

However, the C_I identifying the indifferent voter is derived as function of other parameters (p , q , T e P_A):

Case	Case's Conditions	Indifferent individual's cost of information ³⁹
CASE A	$p < 1/2$	$C_I = p(1-p)q(1+T) - P_A$
CASE B	$p > 1/2$ e $(1-p) > (1-q)p$	$C_I = p[q(1-p) + T(p-2)] + T - P_A$
CASE C	$p > 1/2$ e $(1-p) < (1-q)p$	$C_I = p(1-p)q(1-T) - P_A$

Hence, I should check wheter or not in all cases the condition $C_I \in (a, b)$ is verified: this will ensure me that shares will be included between 0 and 1. This kind of inspection must be done on shares obtained both before (demand for news with generic P_A) and after maximization (demand for news at optimal price P_A^*).

Pre-maximization check

Shares are included between 0 and 1 if the “indifference cost” C_I is included between a and b ; that is

$$\begin{aligned} C_I &> a \\ C_I &< b \end{aligned}$$

To be this the case, I impose in the different cases the following conditions:

CASE	INDIFFERENCE COST	CONDITIONS ⁴⁰
Case A	$C_I = p(1-p)q(1+T) - P_A$	$P_A < p(1-p)q(1+T) - a$ $P_A > p(1-p)q(1+T) - b$
Case B	$C_I = p[q(1-p) + T(p-2)] + T - P_A$	$P_A < p[q(1-p) + T(p-2)] + T - a$ $P_A > p[q(1-p) + T(p-2)] + T - b$
Case C	$C_I = p(1-p)q(1-T) - P_A$	$P_A < p(1-p)q(1-T) - a$ $P_A > p(1-p)q(1-T) - b$

³⁹These C_I are those obtained before maximization.

In all case, conditions result in a restriction on distribution's support of information costs - namely a and b - mainly because prices have to be positive ($P_A \geq 0$). I analyse case by case which are these restriction.

CASE A

In this situation, conditions so far are:

$$\begin{aligned} q &\in (0, 1) \\ p &\in (0, \frac{1}{2}) \\ T &\in (0, 1) \end{aligned}$$

$$\begin{aligned} a &\geq 0 \\ b &\geq 0 \\ b &> a \\ P_A &\geq 0 \end{aligned}$$

I impose restrictions on prices so that $C_I \in (a, b)$:

$$P_A < p(1-p)q(1+T) - a \quad (1)$$

$$P_A > p(1-p)q(1+T) - b \quad (2)$$

To simplify I define $A \equiv p(1-p)q(1+T)$, rearraging (1) and (2)

$$P_A < A - a \quad (1)$$

$$P_A > A - b \quad (2)$$

Depending on the conditions of this case, $A \in (0, \frac{1}{2})$; indeed:

$$A = \underbrace{p}_{\in(0, \frac{1}{2})} \underbrace{(1-p)}_{\in(\frac{1}{2}, 1)} \underbrace{q}_{\in(0, 1)} \underbrace{(1+T)}_{\in(1, 2)}$$

The "size" of A implies the existence of a lower bound on the distribution support that is $a \in (0, \frac{1}{2})$: if $a \geq \frac{1}{2}$ it doesn't exist a $P_A \geq 0$ such that (1) is satisfied. The minimum information cost (a) cannot be too high.

Restrictions on b are not necessary since the larger b becomes, the more easily condition (2) is satisfied; if $b \geq \frac{1}{2}$ condition (2) is satisfied for every $P_A \geq 0$.

$$P_A > A - b$$

$$\begin{array}{ccc} \text{for sure } \geq 0 & \text{for sure } < \text{ Oif } b > \frac{1}{2} \\ \underbrace{P_A}_{\geq 0} & vs & \underbrace{A}_{\in(0, \frac{1}{2})} - \underbrace{b}_{\geq 0} \end{array}$$

Hence, in order to have $C_I \in (a, b)$ and to obtain a share belongig to $(0,1)$ it is necessary to satisfy the following system of conditions

$$\begin{cases} a \in [0, \frac{1}{2}) \\ b > 0 \\ b > a \\ P_A < A - a \\ P_A > A - b \\ \text{with } A \equiv p(1-p)q(1+T) \\ \text{and } A \in (0, \frac{1}{2}) \end{cases}$$

CASE B

In this situation, conditions so far are:

$$\begin{aligned} q &\in (0, 1) \\ p &\in (\frac{1}{2}, 1) \\ T &\in (0, 1) \\ 1-p &> p(1-q) \end{aligned}$$

$$\begin{aligned} a &\geq 0 \\ b &\geq 0 \\ b &> a \\ P_A &\geq 0 \end{aligned}$$

I impose restrictions on prices so that $C_I \in (a, b)$:

$$P_A < p[q(1-p) + T(p-2)] + T - a \quad (1)$$

$$P_A > p[q(1-p) + T(p-2)] + T - b \quad (2)$$

defining $B \equiv p[q(1-p) + T(p-2)] + T$

$$P_A < B - a \quad (1)$$

$$P_A > B - b \quad (2)$$

Depending on the conditions of this case, $B \in (0, \frac{1}{2})$ ⁴¹; indeed:

$$B = \underbrace{p}_{\in(\frac{1}{2}, 1)} \left[\underbrace{q}_{\in(0, 1)} \underbrace{(1-p)}_{\in(0, \frac{1}{2})} + \underbrace{T}_{\in(0, 1)} \underbrace{(p-2)}_{\in(-\frac{3}{2}, -1)} \right] + \underbrace{T}_{\in(0, 1)}$$

The “size” of B implies the existence of a lower bound on the distribution support that is $a \in (0, \frac{1}{2})$: if $a \geq \frac{1}{2}$ it doesn't exist a $P_A \geq 0$ such that (1) is satisfied. The minimum information cost (a) cannot be too high.

⁴¹See graphs for case B in section 3.7.4 at the end of Appendix A

Restrictions on b are not necessary since the larger b becomes, the more easily condition (2) is satisfied; if $b \geq \frac{1}{2}$ condition (2) is satisfied for every $P_A \geq 0$.

$$P_A > B - b$$

$$\begin{array}{ccc} \text{for sure } \geq 0 & \text{for sure } < 0 \text{ if } b > \frac{1}{2} \\ \underbrace{P_A}_{\geq 0} & \text{vs} & \underbrace{B}_{\in(0, \frac{1}{2})} - \underbrace{b}_{\geq 0} \end{array}$$

Hence, in order to have $C_I \in (a, b)$ and to obtain a share belong to $(0,1)$ it is necessary to satisfy the following system of conditions

$$\left\{ \begin{array}{l} a \in [0, \frac{1}{2}) \\ b > 0 \\ b > a \\ P_A < B - a \\ P_A > B - b \\ \text{with } B \equiv p[q(1-p) + T(p-2)] + T \\ \text{and } B \in (0, \frac{1}{2}) \end{array} \right.$$

CASE C

In this situation, conditions so far are:

$$\begin{array}{l} q \in (0,1) \\ p \in (\frac{1}{2}, 1) \\ T \in (0,1) \\ (1-p) < p(1-q) \\ \\ a \geq 0 \\ b \geq 0 \\ b > a \\ P_A \geq 0 \end{array}$$

I impose restrictions on prices so that $C_I \in (a, b)$:

$$P_A < p(1-p)q(1-T) - a \quad (1)$$

$$P_A > p(1-p)q(1-T) - b \quad (2)$$

defining $C \equiv p(1-p)q(1-T)$

$$P_A < C - a \quad (1)$$

$$P_A > C - b \quad (2)$$

Depending on the conditions of this case, $C \in (0, \frac{1}{4})^{42}$; indeed:

$$C = \underbrace{p}_{\in(0, \frac{1}{2})} \underbrace{(1-p)}_{\in(\frac{1}{2}, 1)} \underbrace{q}_{\in(0, 1)} \underbrace{(1-T)}_{\in(0, 1)}$$

The “size” of C implies the existence of a lower bound on the distribution support that is $a \in (0, \frac{1}{4})$: if $a \geq \frac{1}{4}$ it doesn't exist a $P_A \geq 0$ such that (1) is satisfied. The minimum information cost (a) cannot be too high.

Restrictions on b are not necessary since the larger b becomes, the more easily condition (2) is satisfied; if $b \geq \frac{1}{4}$ condition (2) is satisfied for every $P_A \geq 0$.

$$P_A > C - b$$

$$\underbrace{P_A}_{\geq 0} \text{ vs } \underbrace{C}_{\in(0, \frac{1}{4})} - \underbrace{b}_{\geq 0}$$

for sure ≥ 0 for sure < 0 if $b > \frac{1}{4}$

Hence, in order to have $C_I \in (a, b)$ and to obtain a share belongig to $(0, 1)$ it is necessary to satisfy the following system of conditions

$$\left\{ \begin{array}{l} a \in [0, \frac{1}{4}) \\ b > 0 \\ b > a \\ P_A < C - a \\ P_A > C - b \\ \text{with } C \equiv p(1-p)q(1-T) \\ \text{and } C \in (0, \frac{1}{4}) \end{array} \right.$$

Post-maximization check

After maximization, I obtain the following optimal price P_A^* , indifferent cost, demand and profits:

CASE	P_A^*	$C_I(P_A^*)$	$demand(P_A^*)$	Π^*
case A	$\frac{p(1-p)q(1+T)-a}{2}$	$\frac{p(1-p)q(1+T)+a}{2}$	$\frac{p(1-p)q(1+T)-a}{2(b-a)}$	$\frac{[p(1-p)q(1+T)-a]^2}{4(b-a)}$
case B	$\frac{p[q(1-p)+T(p-2)]+T-a}{2}$	$\frac{p[q(1-p)+T(p-2)]+T+a}{2}$	$\frac{p[q(1-p)+T(p-2)]+T-a}{2(b-a)}$	$\frac{\{p[q(1-p)+T(p-2)]+T-a\}^2}{4(b-a)}$
case C	$\frac{p(1-p)q(1-T)-a}{2}$	$\frac{p(1-p)q(1-T)+a}{2}$	$\frac{p(1-p)q(1-T)-a}{2(b-a)}$	$\frac{[p(1-p)q(1-T)-a]^2}{4(b-a)}$

It is important to notice that P_A^* respects always condition (1) by which $C_I > a$, while condition (2) for $C_I < b$ has to be checked in each case.

CASE A

⁴²See graphs for case C in section 3.7.4 at the end of Appendix A

$$\begin{aligned}
P_A^* &= \frac{p(1-p)q(1+T) - a}{2} \\
C_I(P_A^*) &= \frac{p(1-p)q(1+T) + a}{2}
\end{aligned}$$

Using the same notation

$$\begin{aligned}
P_A^* &= \frac{A - a}{2} \\
C_I(P_A^*) &= \frac{A + a}{2}
\end{aligned}$$

Condition (1) is satisfied since $P_A^* = \frac{A-a}{2} < A - a$.

Condition (2) is satisfied if

$$\begin{aligned}
\frac{A - a}{2} &> A - b \\
\underbrace{b - \frac{a}{2}}_{>0} &> \underbrace{\frac{A}{2}}_{\in(0, \frac{1}{2})}
\end{aligned}$$

Post-maximization, condition (2) is not satisfied for every value of $A \in (0, \frac{1}{2})$ - which depend on p , q and T - and for every value of b and of a : I require that $b > \frac{A}{2} + \frac{a}{2}$. However, if $b \geq \frac{1}{2}$ the condition is satisfied for each $a \in [0, \frac{1}{2})$ and $A \in (0, \frac{1}{2})$.

Hence, if $a \in [0, \frac{1}{2})$ and $b \geq \frac{1}{2}$, in case A, I obtain for sure a share of informed voters which is included between 0 and 1 (before and after maximization)⁴³.

CASE B

$$\begin{aligned}
P_A^* &= \frac{p[q(1-p) + T(p-2)] + T - a}{2} \\
C_I(P_A^*) &= \frac{p[q(1-p) + T(p-2)] + T + a}{2}
\end{aligned}$$

Using the same notation

$$\begin{aligned}
P_A^* &= \frac{B - a}{2} \\
C_I(P_A^*) &= \frac{B + a}{2}
\end{aligned}$$

Condition (1) is satisfied since $P_A^* = \frac{B-a}{2} < B - a$.

Condition(2) is satisfied if

⁴³This explain why with $C_i \sim U(0, 1)$, I obtain always proper shares. See 3.7.3

$$\begin{aligned} \frac{B-a}{2} &> B-b \\ \underbrace{b - \frac{a}{2}}_{>0} &> \underbrace{\frac{B}{2}}_{\in(0, \frac{1}{4})} \end{aligned}$$

Post-maximization, condition (2) is not satisfied for every value of $B \in (0, \frac{1}{2})$ - which depend on p , q and T - and for every value of b and of a : I require that $b > \frac{B}{2} + \frac{a}{2}$. However, if $b \geq \frac{1}{2}$ the condition is satisfied for each $a \in [0, \frac{1}{2})$ and $B \in (0, \frac{1}{2})$.

Hence, if $a \in [0, \frac{1}{2})$ and $b \geq \frac{1}{2}$, in case A, I obtain for sure a share of informed voters which is included between 0 and 1 (before and after maximization)⁴⁴.

CASE C

$$\begin{aligned} P_A^* &= \frac{p(1-p)q(1-T) - a}{2} \\ C_I(P_A^*) &= \frac{p(1-p)q(1-T) + a}{2} \end{aligned}$$

Using the same notation

$$\begin{aligned} P_A^* &= \frac{C-a}{2} \\ C_I(P_A^*) &= \frac{C+a}{2} \end{aligned}$$

Condition (1) is satisfied since $P_A^* = \frac{C-a}{2} < C - a$.

Condition (2) is satisfied if

$$\begin{aligned} \frac{C-a}{2} &> C-b \\ \underbrace{b - \frac{a}{2}}_{>0} &> \underbrace{\frac{C}{2}}_{\in(0, \frac{1}{8})} \end{aligned}$$

Post-maximization, condition (2) is not satisfied for every value of $C \in (0, \frac{1}{4})$ - which depend on p , q and T - and for every value of b and of a : I require that $b > \frac{C}{2} + \frac{a}{2}$. However, if $b \geq \frac{1}{4}$ the condition is satisfied for each $a \in [0, \frac{1}{4})$ and $C \in (0, \frac{1}{4})$.

Hence, if $a \in [0, \frac{1}{4})$ and $b \geq \frac{1}{4}$, in case A, I obtain for sure a share of informed voters which is included between 0 and 1 (before and after maximization)⁴⁵.

⁴⁴This explain why with $C_i \sim U(0, 1)$, I obtain always proper shares. See 3.7.3

⁴⁵This explain why with $C_i \sim U(0, 1)$, I obtain always proper shares. See 3.7.3

3.7.3 Specific distribution of information costs: $C_i \sim U(0, 1)$

I consider a specific case of uniform distribution with positive support, namely the case with $a = 0$ and $b = 1$: I proceed in checks pre and post maximisation on informed share with $C_i \sim U(0, 1)$.

CASE A

Before maximization

$$C_I = p(1-p)q(1+T) - P_A$$

In order to ensure that $C_I \in (0, 1)$, it is necessary that

$$\begin{aligned} C_I > 0 &\Rightarrow P_A < p(1-p)q(1+T) \\ &P_A < A \end{aligned} \quad (1)$$

Since $A \in (0, \frac{1}{2})$, it follows that $P_A \in [0, \frac{1}{2})$

$$\begin{aligned} C_I < 1 &\Rightarrow P_A > p(1-p)q(1+T) - 1 \\ &P_A > A - 1 \end{aligned} \quad (2)$$

Since $A \in (0, \frac{1}{2})$, condition (2) is satisfied for each $P_A \geq 0$.

Hence the only condition I need to check is (1): access price cannot be too high.

$$\begin{cases} P_A \in [0, \frac{1}{2}) \\ P_A < p(1-p)q(1+T) \end{cases}$$

After maximization

$$\begin{aligned} P_A^* &= \frac{p(1-p)q(1+T)}{2} \\ C_I(P_A^*) &= \frac{p(1-p)q(1+T)}{2} \end{aligned}$$

Both conditions $C_I > 0$ and $C_I < 1$ are satisfied since numerator belongs to $(0, \frac{1}{2})$.

CASE B

Before maximization

$$C_I = p[q(1-p) + T(p-2)] + T - P_A$$

In order to ensure that $C_I \in (0, 1)$, it is necessary that

$$\begin{aligned} C_I > 0 &\Rightarrow P_A < p[q(1-p) + T(p-2)] + T \\ &P_A < B \end{aligned} \quad (1)$$

Since $B \in (0, \frac{1}{2})$, it follows that $P_A \in [0, \frac{1}{2})$

$$\begin{aligned} C_I < 1 \Rightarrow P_A + 1 &> p[q(1-p) + T(p-2)] + T \\ P_A &> B - 1 \end{aligned} \quad (2)$$

Since $B \in (0, \frac{1}{2})$, condition (2) is satisfied for each $P_A \geq 0$.

Hence the only condition I need to check is (1): access price cannot be too high.

$$\begin{cases} P_A \in [0, \frac{1}{2}) \\ P_A < p[q(1-p) + T(p-2)] + T \end{cases}$$

After maximization

$$\begin{aligned} P_A^* &= \frac{p[q(1-p) + T(p-2)] + T}{2} \\ C_I(P_A^*) &= \frac{p[q(1-p) + T(p-2)] + T}{2} \end{aligned}$$

Both conditions $C_I > 0$ and $C_I < 1$ are satisfied since numerator belongs to $(0, \frac{1}{2})$.

CASE C

Before maximization

$$C_I = p(1-p)q(1-T) - P_A$$

In order to ensure that $C_I \in (0, 1)$, it is necessary that

$$\begin{aligned} C_I > 0 \Rightarrow P_A &< p(1-p)q(1-T) \\ P_A &< C \end{aligned} \quad (1)$$

Since $C \in (0, \frac{1}{4})$, it follows that $P_A \in [0, \frac{1}{4})$

$$\begin{aligned} C_I < 1 \Rightarrow P_A &> p(1-p)q(1-T) - 1 \\ P_A &> C - 1 \end{aligned} \quad (2)$$

Since $C \in (0, \frac{1}{4})$, condition (2) is satisfied for each $P_A \geq 0$.

Hence the only condition I need to check is (1): access price cannot be too high..

$$\begin{cases} P_A \in [0, \frac{1}{4}) \\ P_A < p(1-p)q(1-T) \end{cases}$$

After maximization

$$\begin{aligned} P_A^* &= \frac{p(1-p)q(1-T)}{2} \\ C_I(P_A^*) &= \frac{p(1-p)q(1-T)}{2} \end{aligned}$$

Both conditions $C_I > 0$ and $C_I < 1$ are satisfied since numerator belongs to $(0, \frac{1}{4})$.

3.7.4 Graphs for pre-maximization analysis

Conditions' Check on Case B: Graphs

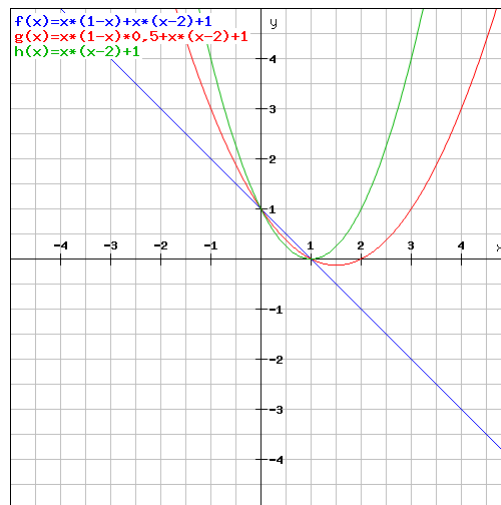

Figure 3.7.1: Caso B: grafico per $B \equiv p[q(1-p) + T(p-2)] + T$

con $T = 1$

$$f(x) = B(q = 1)$$

$$g(x) = B(q = 0,5)$$

$$h(x) = B(q = 0)$$

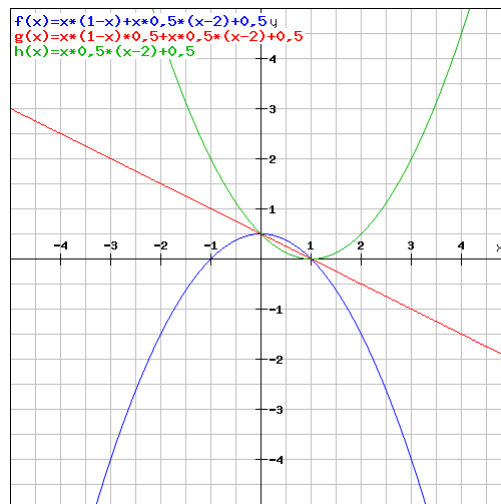

Figure 3.7.2: Case B: graph for $B \equiv p[q(1-p) + T(p-2)] + T$

with $T = 0,5$

$$f(x) = B(q = 1)$$

$$g(x) = B(q = 0,5)$$

$$h(x) = B(q = 0)$$

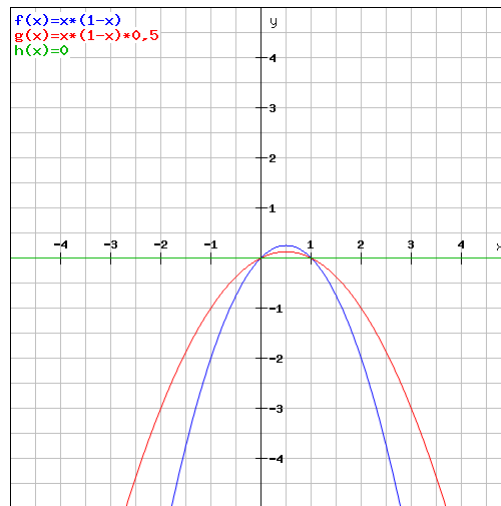

Figure 3.7.3: Case B: graph for $B \equiv p[q(1-p) + T(p-2)] + T$

with $T = 0$

$$f(x) = B(q = 1)$$

$$g(x) = B(q = 0,5)$$

$$h(x) = B(q = 0)$$

Conditions' Check on Case C: Graphs

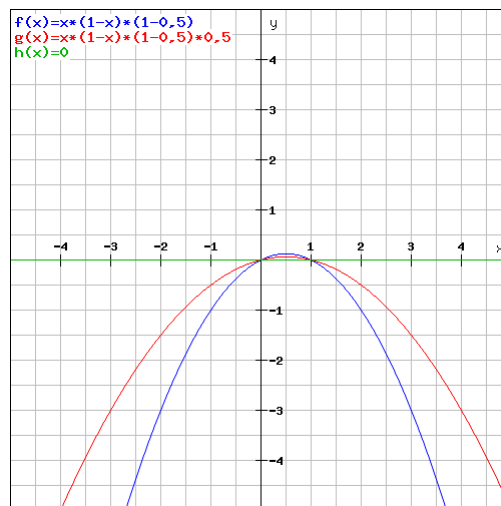

Figure 3.7.4: Case C: $C \equiv p(1-p)q(1-T)$

with $T = 0,5$

$$f(x) = B(q = 1)$$

$$g(x) = B(q = 0,5)$$

$$h(x) = B(q = 0)$$

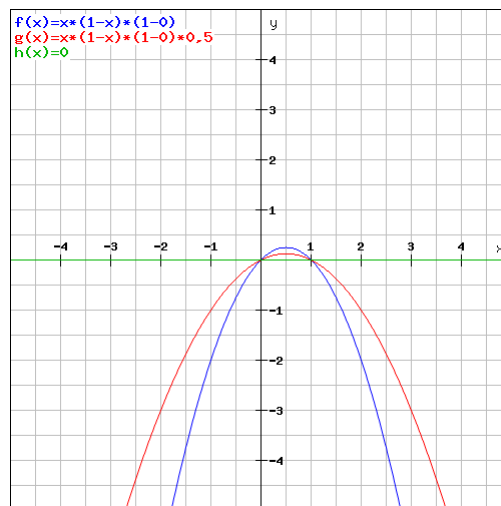

Figure 3.7.5: Case C: $C \equiv p(1-p)q(1-T)$

with $T = 0$

$$f(x) = B(q = 1)$$

$$g(x) = B(q = 0,5)$$

$$h(x) = B(q = 0)$$

3.8 Comparative statics on demand for news

3.8.1 Pre-maximization

Before maximization, the demand for news is:

- (CASE A) $demand = \frac{p(1-p)q(1+T)-P_A-a}{b-a}$ if $p < \frac{1}{2}$
- (CASE B) $demand = \frac{p[q(1-p)+T(p-2)]+T-P_A-a}{b-a}$ if $p > \frac{1}{2}$ and if $(1-p) > (1-q)p$
- (CASE C) $demand = \frac{p(1-p)q(1-T)-P_A-a}{b-a}$ if $p > \frac{1}{2}$ and if $(1-p) < (1-q)p$

Effects of P_A , q and p

Access price P_A has a negative effect on demand in all cases.

Quality q of signals has a positive effect on demand in all cases.

The effect of the probability p of negative events changes according to the case considered. In case A the effect is positive. In case B and case C the effect is negative. Moreover, in the second situation the more p increases the more individuals choose actions indiscriminately (case C).

Effects of heterogeneity ($b - a$)

The effects of heterogeneity strictly depend on the fact of having $S_I \in (0, 1)$ and $S_U = 1 - S_I \in (0, 1)$.

Effect of a (minimum cost of information)

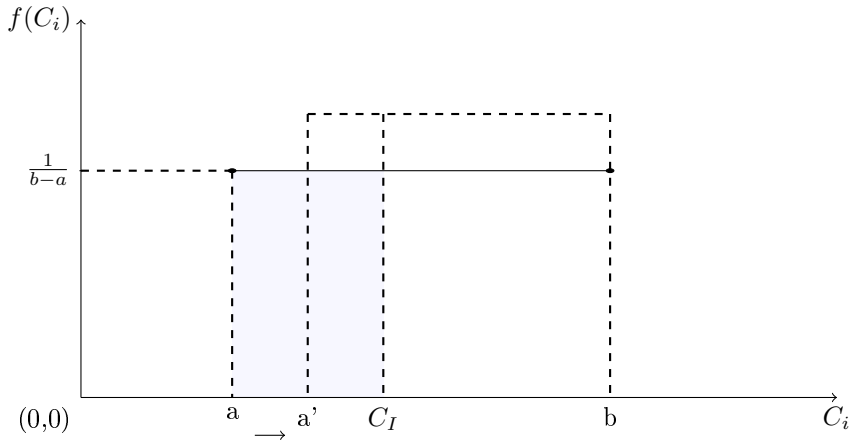
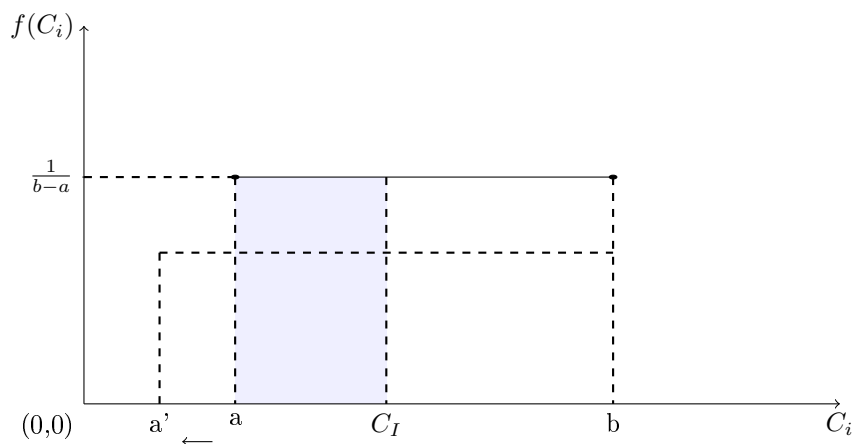

Figure 3.8.1: Effect of increase in a

If a increases ceteris paribus (*less heterogeneity*), the uninformed share increases (there is no change in C_I and density $\frac{1}{b-a}$ increases for each C_i) and, since $S_I + S_U = 1$, the share of informed decreases.

Figure 3.8.2: Effect of decrease in a

If a decreases ceteris paribus (*more heterogeneity*), the uninformed share decreases (there is no change in C_I and density $\frac{1}{b-a}$ decreases for each C_i) and, since $S_I + S_U = 1$, the share of informed increases.

Effect of b (maximum cost of information)

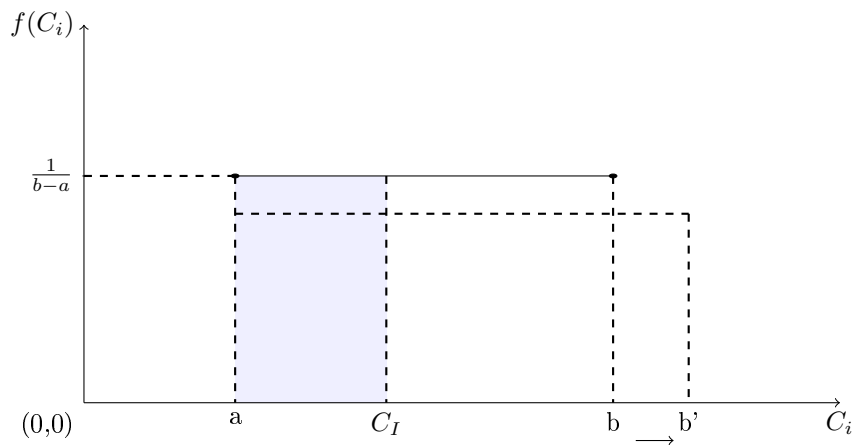
Figure 3.8.3: Effect of increase in b

If b increases ceteris paribus (*more heterogeneity*), the informed share decreases (there is no change in C_I and density $\frac{1}{b-a}$ decreases for each C_i) and, since $S_I + S_U = 1$, the share of uninformed increases.

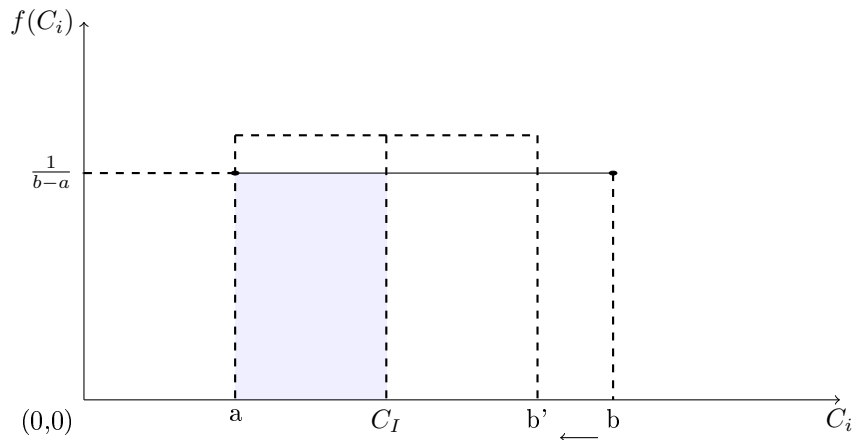
Figure 3.8.4: Effect of decrease in b

If b decreases *ceteris paribus* (*less heterogeneity*), the informed share increases (there is no change in C_I and density $\frac{1}{b-a}$ increases for each C_i) and, since $S_I + S_U = 1$, the share of uninformed decreases.

If the increase/decrease in heterogeneity occurs both because of a decrease/increase in a and an increase/decrease in b , the final effect on demand is ambiguous (the two effects are opposite).

3.8.2 Post-maximization

After maximization, the demand for news is:

- (CASE A) $demand = \frac{p(1-p)q(1+T)-a}{2(b-a)}$ if $p < \frac{1}{2}$
- (CASE B) $demand = \frac{p[q(1-p)+T(p-2)]+T-a}{2(b-a)}$ if $p > \frac{1}{2}$ and if $(1-p) > (1-q)p$
- (CASE C) $demand = \frac{p(1-p)q(1-T)-a}{2(b-a)}$ if $p > \frac{1}{2}$ and if $(1-p) < (1-q)p$

Effects of P_A , q and p

The effects of q , p are the same as in the pre-maximization.

Effects of heterogeneity ($b - a$)

The effects of heterogeneity strictly depend on the fact of having $S_I \in (0, 1)$ and $S_U = 1 - S_I \in (0, 1)$.

The effect of b is the same as in the pre-maximization case.

Effect of a (minimum cost of information)

The effect of a on demand is now more complicated since it modify both the extension of the distribution's support and the indifference cost. These two effects operates in opposite directions, giving an ambiguous effect.

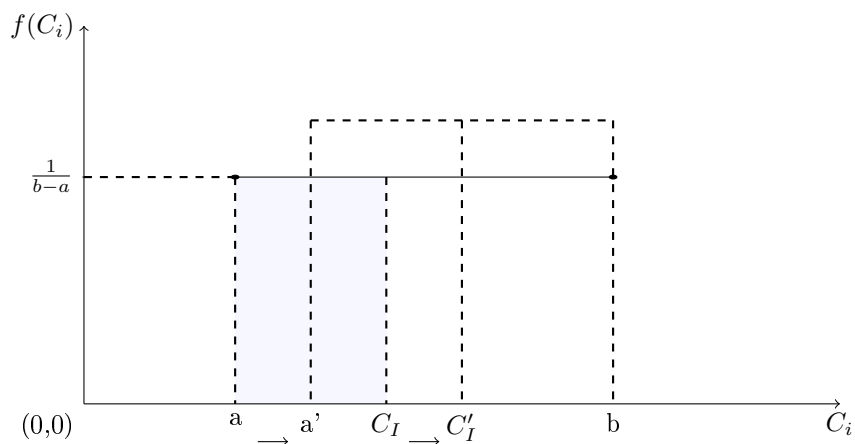
Figure 3.8.5: Effect of increase in a

If a increases (*less heterogeneity*) the uninformed share increases because the density $\frac{1}{b-a}$ increases for each C_i and it decreases because the indifference cost C_I moves to the right.

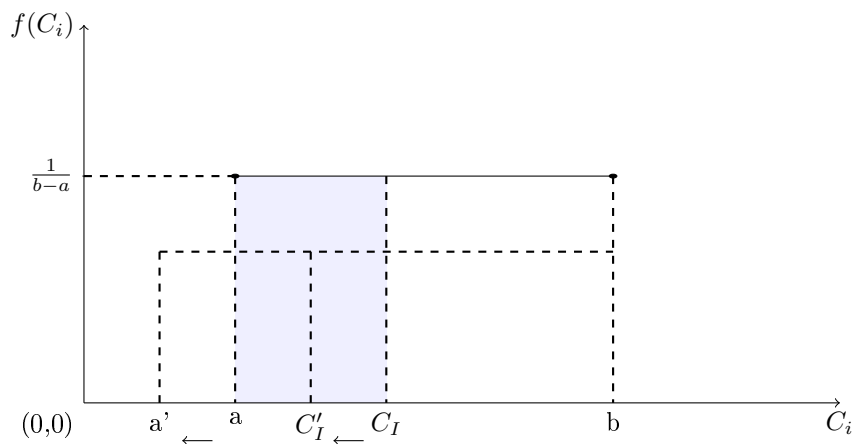
Figure 3.8.6: Effect of decrease in a

If a decreases (*more heterogeneity*), the uninformed share decreases because the density $\frac{1}{b-a}$ decreases for each C_i and it increases because the indifference cost C_I moves to the left.

Effect of b (maximum cost of information)

The effect of b is the same as in the pre-maximization case.

If the increase in heterogeneity occurs both because of a decrease in a and an increase in b , the final effect on demand is again ambiguous. The effect of a is ambiguous with a direct positive effect and a negative effect through C_I ; the effect of b is positive.