



Scuola di Dottorato in Scienze Veterinarie  
per la Salute Animale e la Sicurezza Alimentare

**Università degli Studi di Milano**

**GRADUATE SCHOOL OF VETERINARY SCIENCES  
FOR ANIMAL HEALTH AND FOOD SAFETY**

Director: Prof. Valentino Bontempo

**Doctoral Program in Animal Nutrition and Food Safety**

*Academic Year: 2013-2014*

---

# **Internet of Things (IoT) and Dairy Farm Automation**

**Stefania Leonardi**

---

Tutor:

**Dr. Francesco Maria Tangorra**

Coordinator:

**Prof. Giovanni Savoini**







# Index

<b>1. Foreword</b>	<b>9</b>
1.1 Dairy Farm Automation	11
1.1.1. <i>Automation of milking-related tasks</i>	11
1.1.2. <i>Cow Monitoring</i>	12
1.1.3. <i>Feeding Automation</i>	13
1.2 Precision Dairy Farming	14
1.3 Internet of Things	17
1.3.1. <i>Concept and Vision</i>	17
1.3.2. <i>Smart Farming</i>	19
1.4 References	22
<b>2. Objectives</b>	<b>27</b>
<b>3. Use of a proactive herd management system in a dairy farm of northern Italy: technical and economic results</b>	<b>29</b>
3.1 Abstract	31
3.2 Introduction	31
3.3 Materials and Methods	33
3.4 Results and Discussion	34
3.5 Conclusions	34
3.6 References	35
3.7 List of tables	37
<b>4. Evaluation of an electronic system for automatic calving detection on a dairy farm</b>	<b>39</b>
4.1 Abstract	41
4.2 Introduction	41
4.3 Materials and Methods	42
4.3.1 <i>Data collection and Statistical analysis</i>	43
4.4 Results and discussion	44
4.5 Conclusions	46
4.6 References	46
<b>5. Evaluation of the performance of the first automatic milking system for buffaloes</b>	<b>49</b>
5.1 Abstract	51
5.2 Introduction	52
5.3 Materials and Methods	53
5.3.1 <i>Data Collection</i>	54

5.3.2 <i>Data Selection and Statistical analysis</i>	54
5.4 Results and Discussion	55
5.4.1 <i>Number of Milking per Days and Daily Production</i>	57
5.5 Conclusions	58
5.6 References	59
5.7 List of figures	64
5.8 List of tables	68
<b>6. Methods of estimating Liner Compression</b>	<b>71</b>
6.1 Abstract	73
6.2 Introduction	74
6.3 Materials and Methods	75
6.3.1 <i>Overpressure measurements</i>	75
6.3.2 <i>Artificial teat sensor</i>	76
6.3.3 <i>Statistical analysis</i>	77
6.4 Results and Discussion	77
6.4.1 <i>Overpressure measurements</i>	77
6.4.2 <i>Artificial teat sensor</i>	79
6.4.3 <i>Overpressure vs. Liner Compression measurements</i>	80
6.5 Conclusions	80
6.5.1 <i>Acknowledgements</i>	80
6.6 References	81
6.7 List of figures	83
6.8 List of tables	87
<b>7. General Discussion</b>	<b>89</b>
<b>8. Summary</b>	<b>93</b>
<b>9. Acknowledgements</b>	<b>99</b>







# **CHAPTER 1**

## **Foreword**



# 1. Foreword

## 1.1 Dairy Farm Automation

Automation of the production processes in dairy farming is rising through the world. The major drivers of this change are the reduction of physical labor and labor costs (Svennersten-Sjaunja and Pettersson, 2008; de Koning, 2010). The application of automation fits with the trend of fewer but larger herds, narrower profit margins than in the past, and continuous improvement of technology already available that become less costly (Bewley, 2012; Knijn et al., 2013; Rutten et al., 2013). In general terms, automation refers to the use of machines, control systems and information technologies to enhance productivity in the production processes (Kanjilal et al., 2014). Automation enables dairy farmers to control and manage larger herds, saving time and providing information. This latter aspect is a key factor in managing dairy farm through a “proactive” perspective rather than a “reactive” one, however depending on the skills of each farmer. Indeed, automation and technology themselves do not solve a problem but rather suggest where the problem is. Only within this perspective, automation can lead to benefits as improved profitability, animal health, lifestyle and milk quality.

Usually, on dairy farm, automation concerns three main areas: (i) automation of milking-related tasks; (ii) cow monitoring; (iii) feeding automation.

### *1.1.1 Automation of milking-related tasks*

Automatic Milking System (AMS) refers to a system that automates all the aspects of the milking process and cow management usually undertaken in conventional milking (de Koning and Rodenburg, 2004). Automatic milking represents a revolutionary innovation in dairy farming because the adoption of an AMS is not a simple replacement for a milking parlour but rather a new way of managing a dairy farm. AMS do not simply change the way the milking is carried out but also the farmer's schedule, the feeding and the housing management. With an AMS, milk information from individual cows is measured continuously by using sensors. Additional functions of the system are the monitoring of milk quality, cow and udder health and cow fertility (Meskens et al., 2001). Switching from a conventional milking to automatic milking results in big changes for both the farmers and the animals and requires a different concept of herd management. The labour routine and the cow behavioural routine are modified, some tasks are eliminated while new activities are necessary. Changing of the nature of labour and computerized monitoring of individual animals are probably the greatest innovations related to robotic milking. These aspects offer many potential advantages to both the farmers and

the cows and open new challenges but, at the same time, involve some drawbacks.

Overall, the adoption of an AMS must be assessed on the specific technical and operating characteristics of the farm while the most important factors in successful implementation of an AMS are the attitude and the expectation of dairy farmers (Hogeveen et al., 2001; De Koning et al., 2002; Ouweltjes, 2004). Flexibility and discipline to control the system and the cows, ability to work with computers, big attention to barn layout and cow traffic, regular maintenance of the system and healthy cows are the key factors of a successful implementation of AM-systems (De Koning and Rodenburg 2004).

There are currently about 22.000 AMS installed over the world to milk dairy cows (Tranel, 2013) and AMS can now be considered a well-established technology. They are used both in conjunction with freestall housing and pasture-based operations, and since 2008 the automatic milking of dairy buffaloes was introduced for the first time on a commercial dairy farm in southern Italy (Caria et al., 2014).

### *1.1.2 Cow Monitoring*

Automatic systems to monitor physiological or behavioural parameters, related to the health or the oestrus, of an individual cow and to detect abnormalities of the animals are commonly used in dairy cow farming. Sensors implemented in such systems can be attached or non-attached to the cow. Attached sensors can be placed outside the cow's body (on-cow sensor, e.g. pedometer) or inside (in-cow sensor, e.g. rumen bolus). Non-attached sensors are off-cow sensors that can be classified as in-line sensors, taking measurements in a continuous flow of milk from a cow (e.g. milk electric conductivity) or on-line sensors when automatically collect and analyse milk samples (e.g. somatic cell count sensor) (Rutten et al., 2013).

The most widespread attached sensors used in dairy cow farming are pedometers, activity meters and 3-D accelerometers for automatic detection of oestrus. These devices can either be fastened to the cow's neck or to its foot. They are equipped with an internal battery and an electronic device sensitive to the movements of the cow. The internal memory of the device increments a single counter at each step taken by the cow and the final step count is transmitted with the cow's identification code to the control system when the animal is identified by antennas placed in the milking parlour or directly in the barn. The control system records the number of steps taken by the cow since the previous transmission. The step-count received is compared with the average step counts of the previous days and all the animals that show an increase in activity level are signalled to the farmer, who can evaluate if the cow is in heat and then proceeding with the artificial insemination. The advantages of

automatic oestrus detection have been amply demonstrated, even if this technology brings the greatest benefits to farms with large herds (> 100 cows), where the direct observation of animals is particularly difficult and, sometime, inefficient.

Mastitis detection systems are historically based on in-line measurement of the milk electrical conductivity (EC), even if many studies highlighted that various factors can affect the milk conductivity. In particular, fat and protein contents of the milk inhibit the movement of ions between the electrodes of measurement. A 1 percent increase in fat content results in a 1.5 percent reduction EC and the same effect is produced by an increase in protein content. Moreover, being the EC of the milk a factor closely linked to the single animal and its physiological and health conditions, the increase in conductivity of the milk cannot be assessed using absolute threshold levels, but has to be compared against previously measured conductivity values for the same animal. In particular, data should be interpreted by analyzing the differences between the quarters of the same animal, and/or by comparing values measured over several days in order to isolate the variations due to pathological alterations of the udder. Nevertheless, although a change in milk EC might be a useful indicator, on its own it is not a reliable or sensitive parameter for conclusive diagnosis (Hovinen, 2006; Norberg, 2005).

To overcome the above mentioned limits of the milk EC, other mastitis detection systems were developed, based on milk colour sensors, as the presence of a yellow colour or of blood in the milk might be highly indicative of mastitis, or biosensors to detect specific enzymes (e.g. L-lactate dehydrogenase - LDH) related to the mastitis infection status. LDH has a large potential for detecting clinical mastitis (Friggens et al., 2007) and recently a biosensor using dry-stick technology has been introduced on the market (Mazeris, 2010), but performance of this system has not been systematically evaluated.

Health monitoring systems and related protocols to interpret the output are still to be improved to enhance the practical value on farm. Unlike heat monitoring, characterized by an actionable output (e.g. cow X is ready for artificial insemination), health monitoring systems currently does not produce uniquely and actionable information, due to the high number of false alarms. In the existing systems, high sensitivity (> 80 %) is often combined with low specificity and viceversa (de Mol and Ouweltjes, 2001; Rutten et al. 2013)

### *1.1.3 Feeding Automation*

Feeding is the largest single cost on a dairy farm (up to 50% of total running cost) and it is the most time consuming activity after milking. Feeding automation has long had place in dairy farming, even if it has been limited to automatic concentrate distributors or self-feeders for calves. Automatic feeder

for concentrates dispense concentrates to supplement nutritional requirements not supplied by the forages according to animals' needs, physiological condition or productive capacity. Self-feeders for calves are automatic milk dispenser that administer the feed ratio supplementing, if necessary, each animal's diet automatically. The adoption of this technology has a strong impact on farm management, reducing drastically the time for preparing and dispensing feed to the calves and enabling their health status on an individual basis. Since 2000, automatic feeding (AF) systems for total or partial mixed rations (TMR or PMR) have been developed by research centers (Kazumoto, 1999; Tamaki, 2002) and also by manufacturers (Nydegger and Grothmann, 2009). With AF systems, the farmer is not anymore directly involved in feed preparation and delivery, whilst the feed delivery is programmable enabling more frequent feeding a day. Recent studies on this topic reported the possibility of reducing human labour or making the work schedule more flexible (Bisaglia et al., 2012), stimulating cow feeding activity, dry matter intake, and natural feeding behaviour of more meals per day (De Vries et al, 2005; Mäntysaari et al., 2006; Pompe et al., 2007; Azizi et al., 2009).

## 1.2 Precision Dairy Farming

Automatic technologies allows to control and manage larger herds providing information on an individual cow level. Taking individual cow decisions is one of the main characteristics of Precision Dairy Farming.

Precision dairy farming (PDF), as defined by Eastwood (2008), is “the use of information and communication technologies for improved control of fine-scale animal and physical resource variability to optimise economic, social, and environmental farm performance”. Bewley (2010) defined PDF as the use of new technologies to measure physiological, behavioral, and production indicators on individual cows to improve management strategies and farm performance.

PDF systems are based on state-of-the-art devices that collect information helping farm managers in decision-making. Four steps characterize these systems (Schulze et al., 2007; Rutten et al., 2013):

- (i) sensors that generate data, by measuring specific parameters related to animals (e.g. cow activity);
- (ii) an algorithm that uses sensor data providing information about animals. In this step raw data or processed data (e. g. increasing cow's activity) can be combined with non-sensor data (historical cow's data) (Steenefeld et al.,

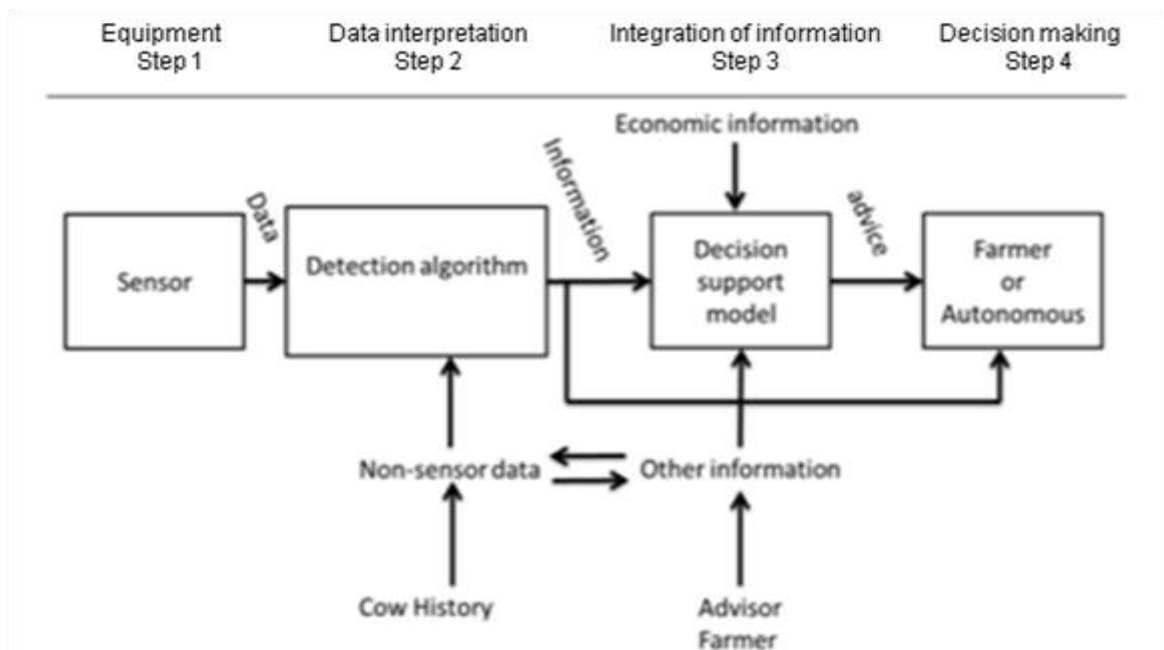
- 2010) providing information about the animals' physiological status (e.g. oestrus);
- (iii) a management decision-making process that by integrating information from the previous step with other information (technical, economic, etc.), if available at farm level, produces an advice (e.g. whether to inseminate a cow or not);
  - (iv) a decision execution by the farmer (e.g. insemination of the cow) or by the system autonomously (e.g. management of cow's access to the milking robot).

The framework describing these four steps in a generic PDF system is shown in Figure 1.

In the development of a PDF system, the most crucial steps are data interpretation and decision making. The first requires the development of algorithms to transform data into useful information, by involving a clear definition of the animal or farm status that needs to be detected, and the associated gold standard. The interpretation of the measured signals is difficult because of the uniqueness of every cow. A common disadvantage of existing models for illness and mastitis detection, based on data gathered by various sensors (e. g. milk yield, electrical conductivity, activity, etc.) is the high number of false alarms, which hampers their practical application. In existing systems, high sensitivity is often combined with low specificity and vice versa (Rutten et al., 2013).

Decision-making has to be based on appropriate management action or standard operating procedure associated with the information provided by the PDF system (Hogeveen and Steeneveld, 2013).

Other important factors that make PDF systems work at farm are the cost-efficiency of the investment and socio-economic aspects. Some PDF systems are aimed at improving disease situations (e.g. mastitis), production efficiency (e.g. automatic feeder for concentrates), and labour reduction (e.g. automatic milking). The benefits of these improvements should be weighed against the investment of the system. Between the socio-economic aspects the farmer's bent to the adoption of technology, and the time and investment irreversibility are the main drivers for the adoption of new technology (Sauer and Zilberman, 2012; Hogeveen and Steeneveld, 2013).



**Figure 1.** From a sensor to a decision in a generic dairy farming management system (Rutten et al., 2013, modified)

Processes suitable for the PDF approach are various in dairy farming, including (Wathes et al., 2008):

- weight monitoring, trough walk over scales in parlour or AMS providing analysis for feeding strategies;
- heat monitoring, by using devices (tags fitted to the neck, ankle or ear of the cow) that monitor activity related to heats and identify optimal windows for artificial inseminations;
- calving monitoring, performed by sensors fixed on pregnant animals;
- milk monitoring of milk yield, milk components (e.g. fat, protein, and somatic cell count), and health issues (e.g. mastitis);
- health monitoring, employing sensors to track movements (head position and restlessness), monitor bodily functions (rumination, feeding, etc.) and behaviours to identify disease, lameness, and other health problems.

Up to date, these processes have been managed separately, but the attention should be focused on their integration. Indeed, the application of an integrated, computerized information system that collects, combine and interprets the mass quantities of data and information obtained from different sources and domains - including sensors, databases, mathematical models, and knowledge basis - enables the maximum potential of this information to be realized (Frost et al., 1997; Bewley, 2012). Under this perspective, the term PDF should not be limited



to monitoring technologies but should encompass the use of automated, mechanized technologies toward refinement of dairy management processes, procedures, or information collection. Currently, these management systems are slowly moving to operate over the internet and are starting to use some of the well-established networking solutions to improve what they offer to the end users (Kaloxylou et al., 2012). This trend is part of the “Internet of Things”.

### **1.3 Internet of Things**

The Internet of Things (IoT) is a neologism referring to the extension of the Internet to the world of objects and concrete places, a framework of uniquely addressable “things” communicating one another to form a worldwide dynamic network (Miorandi et al., 2012; Borgia, 2014).

The aim of this paragraph is to provide an overview on the concept and the vision of such a novel paradigm that is rapidly growing.

#### *1.3.1 Concept and vision*

The concept of IoT is still confused and can have different facets depending on the beholder. This confusion arises both from the blurring of products and technologies involved (ambient technology, ubiquitous technology, sensor web, sensor network, wireless sensor networks, cloud data, smart items, spimes, etc.), and the geographic or national boundaries. In Europe and China the term “Internet of Things” is widely used whilst in the U.S. it is usually referred to as smart object, smart grid, data grid, cloud computing (Guinard, 2011; van Kranenburg et al., 2011).

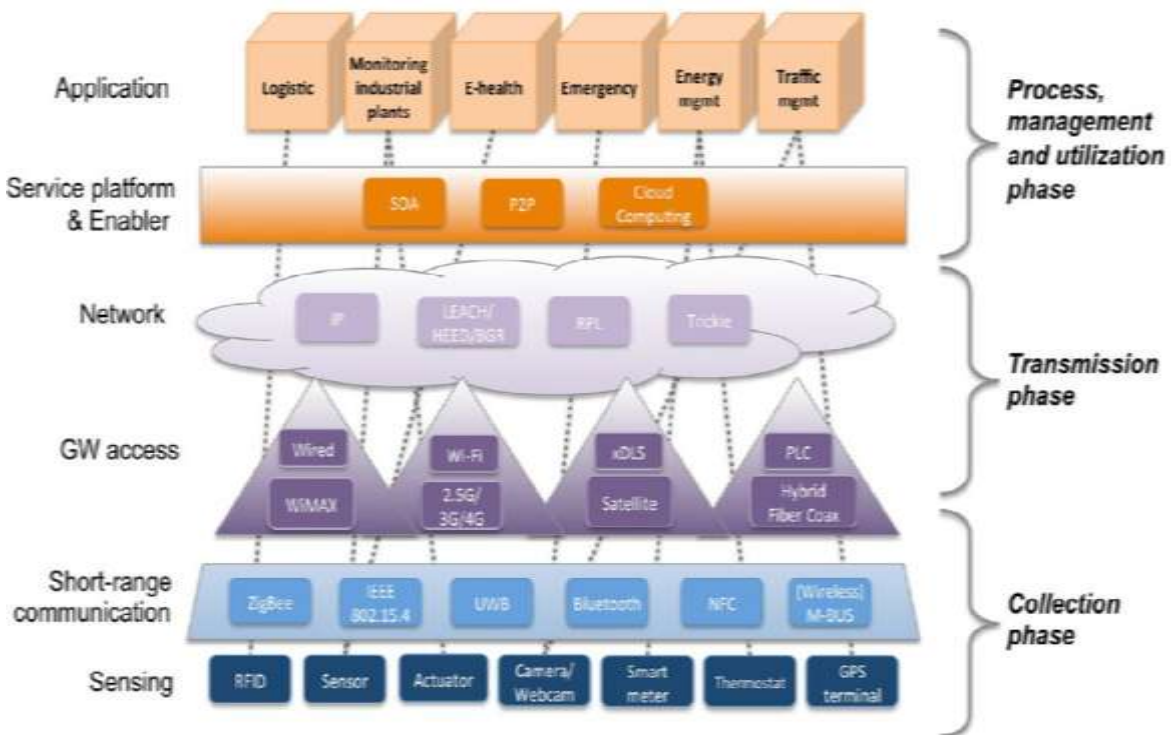
A commonly accepted understanding is the one articulated by the International Telecommunication Union (ITU) (2005) tying together item identification, sensor technologies and their ability to interact with the environment, although the same ITU underlines the fuzziness of this expression, composed by the terms “Internet” and “Things”. “Internet” is defined as “the world-wide network of interconnected computer networks, based on a standard communication protocol, the Internet suite (TCP/IP)”, while “Thing” is “an object not precisely identifiable”. Nevertheless, when these terms are put together, they assume a meaning which introduces a disruptive level of innovation into today ICT (Information and Communication Technologies) world. “Internet of Things” semantically means “a world-wide network of interconnected objects uniquely addressable, based on standard communication protocol” (Atzori et al., 2010). The conventional concept of the Internet as an infrastructure network reaching out to end-users’ terminals fades, leaving space

to a notion of interconnected “smart” objects forming pervasive computing environments (Weiser, 1991).

Smart is synonym of “intelligent”, which comes from the Latin “inter” and “legere”, to read between [the lines]. The objects or “things” become smart thanks to the embedded electronics allowing them to collect information from the environment, to interact with the physical world, and to be interconnected to each other via Internet for exchanging data and information (Borgia, 2014), assuming a proactive role by connecting to the Net (Kortuem G. et al., 2010).

A “thing” can be any real/physical object or a digital/virtual entity that can be uniquely identified by assigned ID numbers, names and/or location addresses, and provided with the ability to transfer data over a network (Borgia, 2014). In this context, the IoT has usually been associated with machine-to-machine (M2M) communication in manufacturing and power utilities, and products built with M2M communication capabilities are usually referred as “smart”.

In the IoT scenario, the physical-cyber world interacts through three levels (Figure 2), identified as: collection phase (perception layer), transmission phase (network layer), and processing-managing-utilization phase (application layer) (Domingo, 2012; Borgia, 2014).



**Figure 2.** Horizontal representation for IoT applications as summarized by Borgia (2014)

In the *collection phase* sensing technologies (RFID, sensors, actuators, cameras, GPS terminal, etc.) provide identification of physical objects and sensing of physical parameters, while short-range communication technologies (IEEE 802.15.4, Bluetooth, ZigBee, etc.) allow data collecting, providing a general perception of the physical environment. Once data is collected, it has to be transmitted across the network to the application layer. Heterogeneous wired and wireless communication technologies (Ethernet, Wi-Fi, 3G/4G, satellite, etc.) enable the access to the Network (*transmission phase*). In the last phase (application layer), information flows are processed, analysed and forwarded to the applications (logistic, energy management, monitoring industrial plants, etc.). In this phase, a key role is carried out by the service platform and enabler such as Service-Oriented Architecture (SOA), Peer to Peer (P2P), Cloud Computing for hiding the heterogeneity of hardware, software, data formats, technologies, and communication protocols of IoT (Atzori et al, 2010; Borgia, 2014). In such scenario, a common operational platform will manage the network and the services, and will abstract across a diverse range of data sources to enable applications to work properly (horizontal approach) (Borgia, 2014).

### 1.3.2 *Smart farming*

The potentialities of IoT for developing new intelligent applications in the areas of automation, sensing and M2M communication is very huge, and provide new opportunities in the dairy industry. However, this potentiality is not fully expressed yet, due to the heterogeneity of technologies and communication standards involved in IoT. Currently many sensors, devices, and actuators are available, but there is no a standardized solution to enable a simple and cohesive interoperability among these systems (Kaloxylou et al., 2012). Moreover, farmers experience an overload of information produced by many sources, not necessarily interrelated and collaborated (Soresen et al., 2010), such as happens with health monitoring technologies (e.g. mastitis detection) that does not currently produce understandable output. As reported by Evans (2011), a monitor cow's health by using wireless sensors implanted in the cow's hear can generate up to 200 MB of data per year and per cow.

A flexible and horizontal approach where applications share infrastructure, environment and network elements and a common service platform manages all the different sources of data and information to enable applications to work properly (Figure 2), is yet in a theoretical and conceptual level (Kaloxylou et al., 2012; Lehman et al., 2012; Soresen et al., 2010).

Up to date, the main achievements of smart farming refer to proprietary or semi-closed herd management systems. Each original equipment manufacturer developed its proprietary ICT infrastructure and dedicated applications, leading to non-interoperable solutions (Figure 3). In such system, various sensors

provide a continuous data flow, using wireless communication protocol, on animals' status (e.g. activity, weight, position, etc.). These data can be stored locally and uploaded in to cloud-based management systems for remote monitoring and control of animals, enabling real time decisions.



**Figure 3** Example of an integrated herd management system based on electronic identification, in which data from different sensors (e.g. pedometers, milk yield recordings, etc.) are collected and processed by a unique platform that controls and manages various aspect of the production process such as individual feeding, separation of sick animals, advices of animals in heat . The entire cycle of the animal can be tracked and managed by and trough this system. In this case data are collected and processed locally, but there is also the option of a cloud-based management. Moreover, the results of data analysis are displayed on PC, smartphone or tablet and the system automatically produces attention alerts about animal in heat or changes in behaviour that may indicate health problems, for example.

## 1.4 References

- Atzori, L., A. Iera, G. Morabito. 2010.** The Internet of Things: A survey. *Comput. Netw.* 54: 2787-2805.
- Azizi, O., O. Kaufmann, L. Hasselmann. 2009.** Relationship between feeding behaviour and feed intake of dairy cows depending on their parity and milk yield. *Livest. Sci.* 122: 156-161.
- Belle, Z., G. André, J. C. A .M Pompe. 2012.** Effect of automatic feeding of total mixed rations on the diurnal visiting pattern of dairy cows to an automatic milking system. *Biosyst. Eng.* 111 (1): 33-39.
- Bewley, J. 2010.** Precision dairy farming: Advanced analysis solutions for future profitability. *Pages 2-17 in Proc. First North Am. Conf. Precision Dairy Management, Toronto, Canada.*
- Bewley, J. 2012.** How precision dairy technologies can change your world. *Pages 65-74 in Penn State dairy Cattle Nutrition Workshop.*
- Borgia, E. 2014.** The Internet of Things vision: Key features, applications and open issues. *Comput. Commun.* 54: 1-3.
- Bisaglia, C., Z. Belle, G. van den Berg, J. C. A. M. Pompe. 2012.** Automatic vs. conventional feeding systems in robotic milking dairy farms: a survey in The Netherlands. *Papers Book number: 978-84-615-9928-8 in CIGR-AgEng 2012 Conference.*
- Caria ,M. F. M. Tangorra , S. Leonardi , V. Bronzo , L. Murgia, A. Pazzona. 2014.** Evaluation oft he performance of he first automatic milking system for buffaloes. *J. Dairy Sci.* 97: 1491-1498.
- de Koning, K., Y. van der Vost, A. Meijering. 2002.** Automatic milking experience and development in Europe. *Pages 11-11 in Proc. First North Am. Conf. Robotic Milking, Toronto, Canada.*
- de Koning, K. and J. Rodenburg. 2004.** State of the art in Europe and North America. *Pages 1-10 in Proc. The Int. Symposium on Robotic Milking, Lelystad, the Netherlands.*

**de Koning, K.** 2010. Automatic milking - Common practice on dairy farms. Pages 52–67 in *Proc. First North Am. Conf. Precision Dairy Management, Toronto, Canada.*

**de Mol, R. M. And W. Ouweltjes.** 2001. Detection model for mastitis in cows milked in an automatic milking system. *Pred. Vet. Med.* 49: 71-82.

**DeVries, T.J., M. A. G. von Keyserlingk, K. A. Beauchemin.** 2005. Frequency of feed delivery affects the behaviour of lactating dairy cows. *J. Dairy Sci.* 88: 3553-3562.

**Domingo, M. C.** 2012. An overview of the Internet of Things for people with disabilities. *J. Netw. and Comput. Appl.* 35: 584-596.

**Eastwood, C.R.** 2008. Innovative precision dairy systems: a case study of farmer learning and technology co-development. *PhD thesis, Land and Food Resources, Agriculture and Food Systems, The University of Melbourne.*

**Evans, D.** 2011. The Internet of Things – How the next evolution of the internet is changing everything. *Cisco White Paper.*

**Friggens, N. C.; M. G. G. Chagunda, M. Bjerring, C. Ridder; S. Hojsgaard; T . Larsen.** 2007. Estimating degree of mastitis from time-series measurements in milk: a test of a model based on lactate dehydrogenase measurements. *J. Dairy Sci.* 90: 5415-5427.

**Frost, A. R., C. P. Schofield, S. A. Beulah, T. T. Mottram, J. A. Lines, C. M. Wathes.** 1997. A review of livestock monitoring and the need for integrated systems. *Comput. Electron. Agric.* 17: 139-159.

**Griffith, C., G. Heydon, D. Lamb, L. Lefort, K. Taylor, M. Trotter.** 2013. Smart Farming: Leveraging the impact of broadband and the digital economy, *CSIRO and University of New England.*

**Guinard, D., V. Trifa, F. Mattern, E. Wilde.** 2011. From the Internet of Things to the Web of Things: Resource Oriented Architecture and Best Practices. Pages 97-129 in *Architecting the Internet of Things, D. Uckelmann, M. Harrison, and F. Michabelles, Eds. New York Dordrecht Heidelberg London: Springer.*

**Hogeveen, H., Y. van der Vost, C. de Koning, B. Slaghuis.** 2001. Concepts et implications de la traite automatisée. *Pages 104-120 in Symposium sur les bovines laitiers, CRAAQ, Canada.*

**Hogeveen, H., and W. Steeneveld.** 2013. Integrating It All: Making It Work and Pay at the Farm. *Pages 113-121 in Proc. Precision Dairy Conference. Rochester, MN.*

**Hovinen, M. A-M. Aisla, S. Pyörälä.** 2006. Accuracy and reliability of mastitis detection with electrical conductivity and milk colour measurement in automatic milking. *Acta Agric. Scand. A-An. 56: 121–127.*

**International Telecommunication Union (ITU).** 2005. The Internet of Things. *Internet Report 2005. www.itu.int/internetofthings.*

**Kaloxyllos, A., R. Eigenmann, F. Teye, Z. Politopoulou, S. Wolfertf, C. Shrank, M. Dillinger, I. Lampropoulou, E. Antoniou, L. Pesonen, H. Nicole, F. Thomas, N. Alonistioti, G. Kormentzas.** 2012. Farm management systems and the Future Internet era. *Comput. Electron. Agric. 89: 130-144.*

**Kanjilal, D., D. Singh, R. Reddy, J. Mathew.** 2014. Smart Farm: Extending Automation To The Farm Level. *Int. J. Sci. Techn. Res. 3(7): 109-113.*

**Kazumoto, I.** 1999. Full-automatic TMR preparation feeding equipment mainly used self-sufficient feed. *Livest. Techn. 526: 2-5.*

**Kortuem, G., F. Kawsar, V. Sundramoorthy, D. Fitton.** 2010. Smart objects as building blocks for the internet of things. *IEEE Internet Comput. 14: 44-51.*

**Knijn, H., H. Taweel, H van Wichen, B. J. Wulfse, M. Vonder.** 2014. Smart dairy farming program in the Netherlands. *Pages 141-142 in Proc. Precision Dairy conference and expo, Rochester, MN.*

**Lehmann, R. J., R. Reiche and G. Schiefer.** 2012. *Comput. Electron. Agric. 89: 158-174.*

**Mäntysaari, P., H. Khalili, J. Sariola.** 2006. Effect of feeding frequency of a Total Mixed Ration on the performance of high-yielding dairy cows. *J. Dairy Sci. 89: 4312-4320.*

**Meskens, L., M. Vandermeresch, E. Mathijs.** 2002. Literature review on the determinants and implications of technology adoption. *Deliverable D1 from EU*

*project Implications of the introduction of automatic milking on dairy farms (QLK5 2000-31006). [www.automaticmilking.nl](http://www.automaticmilking.nl)*

**Miorandi, D., S. Sicari, F. De Pellgrini, I. Chlamtac.** 2012. Internet of things: Vision, applications and research challenges. *Ad Hoc Networks*. 10:1497-1516.

**Norberg, E.** (2005) Electrical conductivity of milk as a phenotypic and genetic indicator of bovine mastitis: a review. *Livest. Prod. Sci.* 96: 129-139.

**Nydegger, F., and A. Grothmann.** 2009. Automatische Fütterung von Rindvieh. Ergebnisse einer Erhebung zum Stand der Technik [Automatic feeding of cattle. Results of a survey on the state of the art]. *ART-Berichte 710. Forschungsanstalt Agroscope Reckenholz-Tänikon ART, Ettenhausen.*

**Ouweltjes, W.** 2004. Demands and opportunity for operational management support. *Deliverable D28 from EU project Implications of the introduction of automatic milking on dairy farms (QLK5 2000-31006). [www.automaticmilking.nl](http://www.automaticmilking.nl).*

**Pompe, J.C.A.M., D. H. J. Alders, L. F.M. Heutinck, C. Lokhorst.** 2007. Automatic individual feeding systems for dairy cows: observations of facility utilization Pages 45-51 in: Cox, S. (Ed.), *Precision Livestock Farming '07, Wageningen Academic Publishers, Greece.*

**Rutten, C. J., A. G. J. Velthuis, W. Steeneveld, H. Hogeveen.** 2013. Sensors to support health management on dairy farms. *J. Dairy Sci.* 96: 1928-1952.

**Sauer, J. and D. Zilberma.** 2012. Sequential technology implementation, network externalities, and risk: the case of automatic milking systems. *Agr. Econ.* 43: 233-251.

**Schulze, C., J. Spilke, W. Lehner.** 2007. Data modeling for Precision Dairy Farming within the competitive field of operational and analytical tasks. *Comput. Electron. Agric.* 59: 39-55.

**Sorensen, C. G., S. Fountas, E. Nash, L. Pesonen, D. Bochtis, S. M. Pedersen, B. Basso, S. B. Blackmore.** 2010. Conceptual model of a future farm management information system. *Comput. Electron. Agric.* 72: 37-47.



- Steenefeld, W., L. C. van der Gaag, W. Ouweltjes, H. Mollenhorst, H. Hogeveen.** 2010. Discriminating between true-positive and false-positive clinical mastitis alerts from automatic milking systems. *J Dairy Sci.* 93(6): 2559-68.
- Svennersten-Sjaunja, K. M., and G. Pettersson.** 2008. Pros and cons of automatic milking in Europe. *J. Anim. Sci.* 86: 37-46.
- Tamaki, K.** 2002. Livestock management with “relaxation” for both humans and domestic animals (4)-III. Development and utilization of full-automatic TMR preparation and feeding equipment. *Animal husbandry* 56(10): 1065-1070.
- Tranel L.** 2013. Is robotic milking a good deal? *Hoard's Dairyman Webinar Archives.* <http://www.extension.iastate.edu/dairyteam/milking-systems>.
- van Kranenburg, R., E. Anzelmo, A. Bassi, D. Caprio, S. Dodson, M. Ratto.** 2011. The Internet of things. *Paper presented for the 1st Berlin Symposium on Internet and Society.*
- Wathes, C. M., H. H. Kristensen, J. M. Aerts, D. Berckmans.** 2008. Is Precision Livestock farming an engineer’s daydream or nightmare, an animal’s friend or foe, and a farmers panacea or pitfall? *Comput. Electron. Agric.* 64: 2-10.
- Weiser, M.** 1991. The computer for the 21st century. *Sci. Am.* 265 (3): 94-104.



# **CHAPTER 2**

## **Objectives**

## 2. Objectives

Automation and sensor-based technologies enable dairy farmers to control and manage larger herds, saving time and providing information about the production process, the herd and the individual animal (Precision Dairy Farming). The most important factors in successful implementation of such technologies are, on one side, the skills, attitude, assessment capability and expectation of dairy farmers, and on the other side the data interpretation to transform data into useful, relevant and actionable information for the farmer, the researchers and the technicians.

The aims of the thesis were:

- (i) to evaluate the use of two precision dairy farming systems to control and manage dairy cows physiological and reproductive aspects (oestrus and calving, respectively) - chapter 3 and chapter 4;
- (ii) to assess the response of dairy buffaloes to automatic milking, examining the relationships between the main milking parameters (milking interval, milk yield and milking time) for this species – chapter 5;
- (iii) to investigate methods of estimating liner compression by using a new test device and a novel artificial teat sensor, both specifically designed and built. – chapter 6.

## **CHAPTER 3**

# **Use of a proactive herd management system in a dairy farm of northern Italy: technical and economic results**

Published in:  
*Journal of Agricultural Engineering (2013) 44(2s):208–210*



### **3. Use of a proactive herd management system in a dairy farm of northern Italy: technical and economic results**

AUTHORS: S. Leonardi<sup>1</sup>, G. Marchesi<sup>2</sup>, F. M. Tangorra<sup>1</sup>, M. Lazzari<sup>1</sup>

<sup>1</sup> *Department of Health, Animal Science and Food Safety, Università degli Studi di Milano;*

<sup>2</sup> *Milkline® S.r.l., Italy*

#### **3.1 Abstract**

Reproductive and economic data were recorded before and one year after the installation of Herd Navigator™ in a dairy farm with AMS (Automatic Milking System) located in a mountain area of Northern Italy. Number of days open reduced from 166 to 103 days, number of days between the first and second insemination decreased from 45 to 28 days, and days for identifying an abortion were 80 % less, from 31 to 6 days. The preliminary results highlight the usefulness of the proactive herd management system installed for the reproduction management. A basic economic model is proposed to evaluate the potential economic benefits coming from the introduction of this technology. The model considers the benefits deriving from the reduction of reproduction problems and, consequently, of days open. Considering the effects related to the above mentioned aspects in a case study involving 60 dairy cows, a return on investment over 5 years has been calculated.

Key words: days open, oestrus detection, proactive herd management

#### **3.2 Introduction**

One of the major factors influencing the profitability of a dairy herd is reproductive performance. Following mastitis, failure in detection of oestrus is the second largest cause of economic losses to dairy farmers (Maatje et al., 1997). Inefficient detection of oestrus has been found to be the leading cause of extended calving intervals (Rounsaville et al., 1979) and the main contributor to the lowering of fertility (Lopez et al., 2004). On the contrary, increasing the detection of oestrus reduces days open and increases profitability with a higher impact at lower oestrus detection rates (Pecsok et al., 1994). Farris (1954) first described the increased physical activity of dairy cows during oestrus. Later studies have confirmed that the measurement of the increase in the number of

steps is a useful tool for the detection of oestrus, especially if associated with a specific algorithm (Moore and Spahr, 1991; Lehrer et al., 1992; Liu and Spahr, 1993; At-Taras and Spahr, 2001; de Mol et al., 2001; Firk et al., 2002; Roelofs et al., 2005). Many oestrus detection systems are used in attempt to improve conception rates, ranging from the simple visual observation of the animals to more specific systems based on the measurement of the cows' activity through pedometers or collar activity meters (Holman et al., 2011). The effectiveness of pedometer-aided detection of oestrus, when compared with visual observation, is quite variable and ranges from 60 to 100%, depending on the study (Lehrer et al., 1992). Pennington (1986) reported an efficiency for visual observation of 45% and for pedometers between 78 % and 96%. Another system for oestrus detection is the analysis of progesterone in milk (Bulman and Lamming, 1978; Royal et al., 2000; Friggens and Chagunda, 2005). In the literature, concentrations less than 3 ng/ml were considered indicative of an oestrus (Lamming and Bulman, 1976). In test carried out on Danish dairy herds, an oestrus breakpoint level of 5 ng/ml was determined (Friggens et al., 2006).

In 2008 an advanced milk analysis tool (Herd Navigator, DeLaval, Sweden) was developed for heat detection, by measuring progesterone, mastitis detection, by measuring lactate dehydrogenase (LDH), and ketosis detection, by measuring beta-hydroxybutyrate (BHB). This system automatically takes representative milk samples of individual cows from specific milking points during milking and automatically selects, through a specific algorithm called "biomodel", which cows must be monitored and sampled at each milking session, and which parameters should be measured when the animals arrive to the milking parlour (Mazeris, 2010). Field tests carried out in Denmark between 2008 and 2009 on three farms with more than 150 animals in lactation showed a heat detection rate (HDR) between 95% and 97%, and a conception rate (CR) ranging from 40% to 63%, using Herd Navigator (HN). Moreover, HN reduced the number of days open on an average of 22 days (Blom and Ridder, 2010). Further tests carried out in 2009 on three farms in Denmark and two farms in Holland, with an average of about 180 heads of Holstein Frisian, had showed an HDR between 97% and 100% and an improvement of pregnancy rate (PR) from a minimum of 7.7% to a maximum of 44.4% (Vreeburg, 2010).

The aim of the study was to evaluate the technical and economic benefits on reproductive management deriving from the introduction of HN in a dairy cow farm located in a mountain area of northern Italy and characterized by robotic milking.



### 3.3 Materials and methods

The study was carried out from September 2011 to September 2012 in a dairy farm located in a mountain area of northern Italy (Trentino-Alto Adige). On average, during the experimental period 60 cows (Holstein Frisian and Brown Swiss) were milked with a Voluntary Milking System (VMS, DeLaval, Sweden) and managed through the integrated herd management software DelPro (DeLaval, Sweden). A HN was installed on September 2011.

The HN is basically composed of:

- a milk sampling station, placed within the VMS, to collect milk samples from individual cows;
- an analysis unit, placed into the milking room, to analyse milk samples for progesterone, LHD, and BHB concentrations.

While cows are being milked, representative milk samples are taken and sent, one-by-one, to the analysis unit. A specific algorithm selects which cow to sample during a certain milking session and which parameters to measure. In particular, the prediction of the reproductive status is driven by the progesterone concentrations in milk. HN takes milk samples for progesterone analysis at varying intervals during the heat cycle, especially on the period up to a new event. After a heat the model asks for samples from day 5 to day 14 to assess if the cow is pregnant or has developed a follicular cyst. Further, the model asks for other samples after day 18 in the heat cycle to find the next heat. In cows that are bred the model follows the development in progesterone: if at day 30 after breeding the progesterone concentration is high, the model assumes that the cow is pregnant and follows the cows for the next 25 days to check for pregnancy. Basic information describing the farm before the installation of HN such as average number of milking cows over the last 12 months, milk yield per lactation, annual culling rate, etc. were collected through the help of the farmer and the veterinarian of the farm. During the experimental trial the reproductive status of the cows was monitored using HN. A start time of 20 days before the end of the voluntary waiting period (VWP) was set as start for progesterone measurements and when alarms occurred (follicular or luteal cyst, pregnancy attention, abortion, etc.) the cows were examined by the veterinarian at the earliest convenience. A partial budget analysis was carried out to assess the potential savings on reproductive management of dairy cows, as a consequence of the HN installation. The cash flows changes were identified at the HN introduction, and costs and benefits were evaluated over a period of 8 years from HN installation.

### 3.4 Results and discussion

Table 1 summarizes some basic information of the farm involved in the study, before the HN installation. The milk yield level and the difference in milk yield between 3rd and 1st lactation cows are equivalent to the values of the “Po Valley” intensive dairy farms. The main reproductive data recorded before and after the HN installation are shown in table 2. The absence of an electronic oestrus identification before the HN installation was the main responsible for the low HDR (45 %) and PR (18 %), and the high number of days open (166 days) recorded in the farm. After the HN installation a strong improvement of the reproductive performance was observed. In particular the abortion identification reduced from 31 days to 6 days (-80 %), the days from 1st and 2nd insemination decreased of about 38 % (from 45 days to 28 days), while the average days open changed on average by 63 days (from 166 days to 103 days). As a consequence, the HDR has more than doubled (from 45 to 96 %), the CR increased from 40 % to 64 %, and the PR grew strongly from 18 % to about 61 %. Main benefits and costs related to the reproductive management, resulting from the HN installation, are summarized in Table 3.

Considering an initial investment of 70,000 € for the HN, a real interest of 1.5 % (net inflation), an estimated shelf life of 8 years, a recovery value of 10% compared to the initial value, and an extraordinary maintenance after 4 years as 10% of the investment value, the following indexes were calculated:

- a five-year Return on Investment (ROI);
- a net annual value of 48,500 €;
- an Internal Rate of Return (IRR) of 15%.

Up to the time in which the test was ended, the other HN function associated to mastitis and ketosis detection do not have shown their utility in improving the herd status probably due to the fact that this last was initially of a good level.

### 3.5 Conclusions

The test has been carried out in a mountain area farm situation in which the herd initial status was characterized by a limited cows number, good milk yield and quite low reproductive indexes. In this specific situation, the HN has shown its capacity to assure a single cow better control that has led to an high improvement of the average reproductive indexes. The enhancement of the economic performances related only on this aspect it has been sufficient to guarantee an acceptable ROI value for the economic investment associated to the HN adoption. It can be supposed that these encouraging results would be further improved in the future when the additional HN management options

(LDH analysis for mastitis detection, Urea and RHR for ketosis detection and feeding improvement) will produce their effect on the herd.

### 3.6 References

**At-Taras, E. E., S.L. Spahr .** 2001. Detection and characterization of heat in dairy cattle with an electronic heatmount detector and an electronic activity tag. *J. Dairy Sci.* 84: 792-798.

**Blom, Y. J, C. Ridder.** 2010. Reproductive Management and Performance Can be Improved by Use of DeLaval Herd Navigator<sup>®</sup>. *Proc. First North Am. Conf. Precision Dairy Management, Toronto, Canada..*

**Bulman, D. C., G. E. Lamming.** 1978. Milk progesterone levels in relation to conception, repeat breeding and factors influencing acyclicity in dairy cows. *J. Reprod. Fert.* 54: 447-458.

**de Mol, R. M., W. Ouweltjes, G. H .Kroeze, M. M. W. B. Hendriks.** 2001. Detection of estrus and mastitis: field performance of a model. *Appl. Eng. Agric.* 17: 399-407.

**Firk, R., E. Stamer, W. Junge, J. Krieter.** 2002. Automation of oestrus detection in dairy cows: a review. *Livest. Prod. Sci.* 75: 219-232.

**Friggens, N. C., M. G. G. Chagunda.** 2005. Prediction of the reproductive status of cattle on the basis of milk progesterone measures: model description. *Theriogenology.* 64: 155-190.

**Holman, A., J. Thompson, J. E Routly, J. Cameron, D. N. Jones, D. Grove White, R. F. Smith, H. Dobson.** 2011. Comparison of oestrus detection methods in dairy cattle. *Vet. Rec.* 169: 47.

**Lamming, G. E., D. C. Bulman.** 1976. Use of milk progesterone radioimmunoassay in diagnosis and treatment of subfertility in dairy cows. *Br Vet. J.* 132: 507-517.

**Lehrer, A. R., G. S. Lewis, E. Aizinbud.** 1992. Oestrus detection in cattle: recent developments. *Anim. Reprod. Sci.* 28: 355-361.

- Liu, X., S. L. Spahr.** 1993. Automated electronic activity measurement for detection of oestrus in dairy cattle. *J. Dairy Sci.* 76 (10): 2906-2912.
- Lopez, H., L. D. Satter, M. C. Wiltbank.** 2004. Relationship between level of milk production and estrous behaviour of lactating dairy cows. *Anim. Reprod. Sci.* 81: 209-223.
- Maatje, K., S. H. Loeffler, B. Engel.** 1997. Predicting optimal time of insemination in cows that show visual signs of oestrus by estimating onset of oestrus with pedometers. *J. Dairy Sci.* 80: 1098-1105.
- Mazeris, F.** 2010. DeLaval Herd Navigator<sup>®</sup> Proactive Herd Management. Pages 26–27 in *Proc. First North Am. Conf. Precision Dairy Management, Toronto, Canada.*
- Moore, A. S., S. L. Spahr.** 1991. Activity monitoring and an enzyme immunoassay for milk progesterone to aid in the detection of estrus. *J. Dairy Sci.* 74 (11): 3857-3862.
- Pecsok, S. R., M. L. McGilliard, and R. L. Nebel.** 1994. Conception rates.1. Derivation and estimates for effects of estrus detection on cow profitability. *J. Dairy Sci.* 77:3008-3015.
- Pennington, J. A., J. L. Albright, and C. J. Callahan.** 1986. Relationships of sexual activities in oestrous cows to different frequencies of observation and pedometer measurements. *J. Dairy Sci.* 69: 2925-2934.
- Roelofs, J. B., F. J. C. M. van Eerdenburg, N. M. Soede, B. Kemp.** 2005. Pedometer readings for estrous detection and as predictor for time of ovulation in dairy cattle. *Theriogenology* 64 (8): 1690–1703.
- Royal, M. D., A. O. Darwash, A. P. F. Flint, R. Webb, J. A. Woolliams, G.E Lamming.** 2000. Declining fertility in dairy cattle: changes in traditional and endocrine parameters of fertility. *Anim. Sci.* 70:487–501.
- Rounsaville, T. R., P. A. Oltenacu, R. A. Milligan, and R. H. Foote.** 1979. Effects of heat detection, conception rate, and culling policy on reproductive performance in dairy herds. *J. Dairy Sci.* 62 (9): 1435-1442.
- Vreeburg, N.** 2010. Precision Management On Two Dutch Dairy Farms By Use Of Herd Navigator<sup>®</sup>. Pages 104-105 in *Proc. First North Am. Conf. Precision Dairy Management, Toronto, Canada.*

### 3.7 List of tables

**Table 1.** Farm overview

Cows in lactation [n]	60
Milk yield level [kg/lactation]	11000
Difference in milk yield between 3 <sup>rd</sup> and 1 <sup>st</sup> lactation cows [kg]	1300
Days per year with reduced attention to heats (harvest, holidays etc.) [n]	90
Annual culling rate [%]	30
Average salary for own work [€/h]	20
Milk price [€/kg]	0.40
Average price for heifers - 24 months [€/heifer]	2000
Slaughter price per cow culled due to reproduction problems [€/cow]	500
Price per insemination (semen + labour) [€]	23
Cost per pregnancy check [€/day]	4
Cost per days open [€/day]	2
Voluntary waiting period (VWP) [days]	60

**Table 2.** Main reproductive data before and after the HN installation.

<b>Reproductive data</b>	<b>Before HN installation</b>	<b>After HN installation</b>
No. of pregnancy check per cow per lactation [n]	3.0	1.0
Veterinarian cost [€]	40.00	-
Surveillance of pregnancy check [h/check]	0.04	0.04
Time spent to heat detection [h/days]	1	1
Avg. of Days In Milk (DIM) at the first insemination [days]	85	65
Days after latest heat for identify luteal cysts (before typically by the time of pregnancy check) [days]	40	20
Cystic cows culled [%]	35	5
Days after abortion/1 <sup>st</sup> heat [days]	31	6
HDR [%]	45	96
CR [%]	40	64
PR [%]	18	61.4
Days from 1st to 2nd insemination [days]	45	28
Average days open [days]	166	103

**Table 3.** Main benefits and costs related to the reproductive management,

<b>Benefits</b>	<b>[euro/year]</b>
Increase in average milk yield and less feed due to reduced days open	7560.00
Reduced labour	7300.00
Reduced veterinarian costs	4800.00
Reduced insemination costs	2760.00
Reduced cull cows	2092.50
<i>Total benefits</i>	24512.50
<hr/>	
<b>Costs</b>	
Service and sticks [130 €/year*cow]	7800.00
Electrical power	547.50
Other	182.50
<i>Total costs</i>	8530.00

## **CHAPTER 4**

# **Evaluation of an electronic system for automatic calving detection on a dairy farm**

Published in:  
*Animal Production Science (2013) 53(10):1112–1114*





## 4. Evaluation of an electronic system for automatic calving detection on a dairy farm

AUTHORS: G. Marchesi, \* S. Leonardi,\* F. M. Tangorra, \* A. Calcante, † E. Beretta, \* E. Pofcher, ‡ and M. Lazzari \*

\* *Department of Health, Animal Science and Food Safety, Università degli Studi di Milano, Via Celoria 10, 20133 Milan, Italy.*

† *Department of Agricultural and Environmental Sciences, Università degli Studi di Milano, Via Celoria 2, 20133 Milan, Italy.*

‡ *Zootecnia II (Bovinos y Equinos), Facultad de Ciencias Veterinarias, Universidad Nacional de La Plata, Calle 60 y 118 S/N, CC 296, 1900 La Plata, Argentina.*

*Corresponding author. Email: stefania.leonardi1@unimi.it*

### 4.1 Abstract

Precise calving monitoring is important for reducing the effects of dystocia in cows and calves. The C6 birth control system is an electronic device that detects the time of the expulsion phase during calving. Several 53 Holstein were fitted on day  $280 \pm 5$  of gestation with the C6 birth control system, which was left in place until confirmation of calving.

Sensitivity and PPV of the system were calculated as 100 and 95%, respectively. The partum events occurring at the group fitted with the system were compared with the analogous occurred at 59 animals without device. When alarmed by the system farm staff were in the calving barn during the expulsion phase in 100% of cases. On the contrary the cows without the device were assisted only in 17% of cases ( $P < 0.001$ ).

### 4.2 Introduction

The calving time has been considered the most crucial moment on a dairy farm. A difficult birth can cause trauma for the cow and the calf (Johanson and Berger 2003). The cow may experience reduced milk production or uterine infection, resulting in additional veterinary costs and decreased fertility, which may lead to premature culling (Dematawena and Berger 1997).

The calving assistance and the calving prediction should be considered as the elements that allow an operator to get an action to reduce possible injuries to the calf, caused by the cow or the environment (Mee 2004).

Calving monitoring is particularly important for cows suffering from poor health along with primary labour insufficiencies as well as for cows with very valuable offspring (e.g. calves produced by embryo transfer) (Streyl et al. 2011).

The variability of the pregnancy period and the uncertainty to identify the precise moment of birth reduce the probability of having a quick act (Hodge et al. 1982; Bleul et al. 2006). Many protocols have been implemented to predict the exact moment of birth through the analysis of changes in body temperature (Fujimoto et al. 1988; Aoki et al. 2005), observation of ultrasound findings (Wright et al. 1988), analysis of blood levels of estrone sulfate and of 17- $\beta$ -oestradiol (Shah et al. 2007) or progesterone blood level (Matsas et al. 1992; Streyl et al. 2011), progressive relaxation of the ligaments of the pelvis (Dufaty 1971), and electrolyte concentrations in mammary secretions (Bleul et al. 2006). High costs, difficulties of execution or lack of quality staff have limited the use of the abovementioned systems in practice.

Recently an electronic system for calving monitoring (C6 birth control, Sisteck s.r.l., Italy) in dairy cows has been introduced on the market. This device is sutured at the vulva lips in pregnant cows close to calving time and when it is activated by fetal membranes expulsion a radio wave signal is sent to a receiver installed in the calving barn. Through the use of the Global System for Mobile communication (GSM) technology, the receiver sends a short text message to the farmer's mobile phone warning him of the coming delivery. Preliminary observations of this system, for predicting time of parturition in dairy cows, were carried out by Paolucci et al. (2008). More recently a study was performed to test the reliability of this system as a tool for reducing perinatal mortality and preventing the majority of postpartum reproductive pathologies (Paolucci et al. 2010).

The aim of the present study was to estimate the sensitivity and positive predictive value (PPV) of the C6 birth control system on a commercial dairy farm.

### **4.3 Materials and methods**

The C6 birth control system consists of a transceiver and a receiver apparatus equipped with a GSM modem. The transceiver, powered by two internal lithium 1.5-V 0.26 Ah batteries, is composed by two distinct parts: a rectangular water-resistant plastic shell (4.9 by 2.1 by 1 cm), sutured on the vulva left side; a cylindrical mobile part, sutured on the right side. The mechanical separation of

the transceiver mobile part activates a radio wave transmission to the receiver-transmitter apparatus. The receiver-transmitter is a rectangular box 25 by 20 by 5 cm powered by a rechargeable Li-Ion buffer battery (3.7 V, 0.85 Ah). It receives the signal from each miniaturized transmitter, by wave transceiver 433 MHz, in a range of 100 m. The receiver-transmitter process the signal and, through a GSM quad-band module (850/900/1800/1900 MHz), sends an alarm text message (Short Message Service) with event date and time up to eight different mobile phones.

The C6 birth control tests were carried out during 1 year (September 2010–September 2011) on a Holstein Friesian dairy farm located in Northern Italy.

A total of 112 cows were involved in the study: 53 animals (22 primiparous and 31 multiparous) were monitored using the electronic system for birth control (Group A), and 59 animals (22 primiparous and 37 multiparous) constituted the control group (Group B) without electronic birth control assistance.

The primiparous and multiparous cows were randomly assigned to each group.

On Day  $280 \pm 5$  of gestation the farm staff checked the animals. If one or more cows showed the premonitory signs of early calving (discharge of the liquefied mucous plug sealing the uterus, enlargement of the udder, relaxation of the pelvic ligaments), they were moved to the calving barns (CB) named CB1 and CB2, located in two different farm areas. The CB consisted of a box (10 by 10 m) with a rough concrete floor covered with straw. The transceiver was applied by the veterinary farm just upon the ventral commissure of the vulva of the cows belonging to Group A, in the CB1. After washing the vulva with iodopovidone 10% and the infiltration of a local anaesthetic (Lidocaine 1%, 3–5 mL), the transceiver was sutured using a needle-thread ASSUNYL (Assut Europe, Italy) polyamide monofilament, non-absorbable, with high tensile strength. The cows of Group B, without the device, were visually controlled, in the CB2 calving area, for 10 minutes at 6 a.m. and 6 p.m. (before each milking session), conversely the cows in the CB1 (Group A) were observed only after the C6 birth control alarm.

#### *4.3.1 Data collection and statistical analysis*

The following data were recorded for the animals of Group A: installation time of the transceiver (min); time of alarm activation (hh:mm); arrival time of the farm staff in the calving barn after the alarm (hh:mm); end time of delivery (hh:mm); length of parturition time from alarm to completion of fetus expulsion (min).

Sensitivity of the electronic system was calculated as the number of true calving observed divided by the total of calving events. The PPV of the electronic system was defined as the number of true calving divided by the number of the true calving and false calving.

Recording of animals of Group B: the farm staff were in the calving barn during the calving (Yes/No); the arrival time of the farm staff at the moment of the calving (hh:mm).

Statistical analysis was carried out using SAS9.2 for Windows (SAS Institute Inc., Cary, NC, USA). Fisher's exact test was performed for testing the relationship between calving detection methods (automatic and visual detection) and calving observation (positive and negative).

#### 4.4 Results and Discussion

The average time needed to apply the transceiver was  $5.2 \pm 0.5$  and  $4.6 \pm 0.5$  min, respectively for primiparous and multiparous cows, but there were no significant differences. These values are comparable with those obtained by Paolucci et al.(2008).

On average calving occurred  $5 \pm 3$  days after the application of the transceiver and  $2 \pm 1$  days earlier than the herd management software prediction. Calving was observed mainly in the evening and in the night both for primiparous and multiparous cows, respectively, with  $\sim 58$  and  $60\%$  of the total calving events recorded between 6 p.m. and 6 a.m., which usually is the quieter period of the day with fewer people in the barn.

During the experimental period, three false calving alarms were recorded on a total of 56 calvings. The false alarms were caused by the friction of the animal against the fence of the barn, with the consequently accidental separation of the two parts of the transceiver.

On average  $22.0 \pm 6.0$  min was the time required by the farm staff to reach the calving barn after the alarm activation. During the visit  $96.0\%$  of the cows showed an anterior longitudinal calf presentation while the remaining  $4.0\%$  showed a posterior longitudinal position of the calf. This factor did not affect the health of the calves.

The length of parturition was  $50.0 \pm 23.0$  and  $48.0 \pm 28.0$  min, respectively, for primiparous and multiparous cows, even if no statistically significant differences were observed between the two categories of animals. The values found for multiparous cows are comparable with those obtained by Paolucci et al.(2008), but for primiparous cows are much lower ( $-40\%$ ). The difference could be explained considering that in the study carried out by Paolucci et al.(2008)  $41.2\%$  of heifers have required pulling assistance and  $17.7\%$  of them presented dystocia due to calves' postural defects.

The C6 birth control system showed a sensitivity of  $100\%$  and a PPV of  $95\%$ . These values are higher if compared with other methods and physiological indicators used for predicting parturition times. The changes in body

temperature, measured rectally as well as vaginally, were investigated by many authors (Dufaty 1971; Birgel et al. 1994; Aoki et al. 2005) and there is conflicting information in the literature about the predictive value of these parameters. Different authors described a drop of at least 0.4°C within 22 h before parturition (Dufaty, 1971; Birgel et al., 1994; Lammoglia et al., 1997). In contrast, another study (Rexha and Grunert, 1993) found that observed changes in body temperature within the last 36–24 h before parturition have no significant predictive value. Streyl et al.(2011) found that the change in body temperature before calving appears to be of little value for predicting calving within 24 h. However, body temperature must be monitored for at least 3 days before parturition, and it is not possible to give a predictive answer about parturition from a single examination. Additionally, it is unclear if the described decline in body temperature occurs equally in animals suffering from fever.

Attempts have also been made to predict calving time based on individual external signs including relaxation of the pelvic ligaments (Berglund et al. 1987; Birgel et al. 1994), swelling of the vulva, and udder distension showing that the presence of very relaxed ligaments indicates that parturition will probably occur within 24–72 h.

Regarding the progesterone profiles it has been shown that a reduction in progesterone concentrations below 1.2 ng/mL is currently the most accurate way to predict calving time within 24–12 h (Matsas et al., 1992; Birgel et al., 1994; Streyl et al., 2011). Depending on the type of test used and if the blood samples were frozen or not, the sensitivity and the PPV were between 80 and 93% and 75 and 89%, respectively.

Streyl et al.(2011), by combining parturition score of different clinical signs (broad pelvic ligaments relaxations, filling of the teats, hyperplasia of the udder) and a progesterone rapid blood test, found sensitivity between 89 and 91%and a PPV between 53 and 66% to predict the calving within 12 h. Moreover, it should be considered that calving signals and body temperature in a dairy cow are influenced by many factors (Chikamune et al., 1986; Mosher et al., 1990).

All the above-mentioned methods can predict the parturition time in a range between 12 and 24 h but not at the exact moment of the expulsion phase.

Using C6 birth control, excluding the early false alarms, the calving observation by the farm staff in the CB1 was 100%. Without the device, during calving the farm staff were nearby in the CB2 only in 17%of the cases: in 83%of cases staff arrived in the barn when the calf was already born. The presence of the farm staff during the calving with the two methods differs significantly ( $P < 0.001$ ).

## 4.5 Conclusions

The transceiver application does not require much time and the normal livestock working routine requires minimal modification to include it. The professional work requirements to perform the surgical application can be supported weekly by the veterinarian.

The C6 birth control system proved to be a useful and reliable tool to detect the incoming fetus expulsion allowing the farm staff to be present at the moment of calving and assist the animals if necessary, preventing, therefore, possible problems for the cow and the calf. This is of great interest particularly with heifers and with cows suffering from poor health.

Despite this, it is important to underline that the device just sends an alarm and excellent results can be obtained only if there is a responsible and ready-to-act farm staff and then good management of the calving barn. The possibility of applying the device without suture, using for example a sticking plaster, could in the future simplify its use, avoiding the necessity of the veterinarian during the application, and increasing its diffusion.

## 4.6 References

**Aoki, M., K. Kimura, O. Suzuki.** 2005 Predicting time of parturition from changing vaginal temperature measured by data-logging apparatus in beef cows with twin fetuses. *Anim. Reprod. Sci.* 86: 1-12.

**Berglund, B., j. Philipsson , Ö. Danell.** 1987. External signs of preparation for calving and course of parturition in Swedish dairy cattle breeds. *Anim. Reprod. Sci.* 15:61-79.

**Birgel EH Jr, Grunert E, Soares JA** (1994) The preliminary stage of labor in cattle in relation to the clinical signs of labor and the course of progesterone secretion for the prediction of the calving time. *DeutscheTierärztlicheWochenschrift* 101: 355–359.

**Bleul, U., S. Spirig, M. Hässig, W. Kähn.** 2006. Electrolytes in bovine prepartum mammary secretions and their usefulness for predicting parturition. *J. Dairy Sci.* 89: 3059–3065.

**Chikamune, T , Y. Kanai, H. Shimizu.** 1986. Comparison of effects of seasonal climatic changes on thermoregulatory responses and plasma

concentrations of thyroid hormones in swamp buffaloes and cattle. *Jpn. J. Zoot. Sci.* 57: 778–784.

**Dematawena, C. M. B. and P. J. Berger.** 1997. Effect of dystocia on yield, fertility, and cow losses and an economic evaluation of dystocia scores for Holsteins. *J. Dairy Sci.* 80: 754–761.

**Dufaty, J. H.** 1971 Determination of the onset of parturition in Hereford cattle. *Aust. Vet. J.* 47: 77–82.

**Fujimoto, Y., E. Kimura, T. Sawada, M. Ishikawa, H. Matsunaga, J. Mori.** 1988. Change in rectal temperature, and heart and respiration rate of dairy cows before parturition. *Jpn. J. Zoot. Sci.* 59: 301–305.

**Hodge, P. B., S. J. Wood, R. D. Newman, R. K. Shepherd.** 1982. Effect of calving supervision upon calving performance of Hereford heifers. *Aust. Vet. J.* 58: 97–100.

**Johanson, J. M., P. J. Berger.** 2003 Birth weight as a predictor of calving ease and perinatal mortality in Holstein cattle. *J. Dairy Sci.* 86: 3745–3755.

**Lammoglia, M. A., R. A. Bellows, R. E. Short, S. E. Bellows, E. G. Bighorn, J. S. Stevenson, R. D. Randel.** 1997. Body temperature and endocrine interactions before and after calving in beef cows. *J. Anim. Sci.* 75: 2526–2534.

**Matsas, D. J., R. L. Nebel, K. D. Pelzer.** 1992. Evaluation of an on-farm blood progesterone test for predicting the day of parturition in cattle. *Theriogenology* 37(4): 859–868..

**Mee, J. F.** 2004 Managing the dairy cow at calving time. *Vet. Clin. N. Am.-Food A.* 20: 521–546.

**Mosher, M. D., J. S. Ottobre, G. K. Haibel, D. L. Zartman.** 1990. Estrual rise in body temperature in the bovine II. The temporal relationship with ovulation. *Anim. Reprod. Sci.* 23: 99–107.

**Paolucci, M., A. DiGiambattista, L. Sylla, M. Menichelli, A. Banchio, M. Monaci.** 2008. Predicting time of parturition in Holstein Friesian cows by using C6 Birth Control<sup>®</sup>. *Reprod. Domest. Anim.* 43: 57–58.

**Paolucci, M., L. Sylla, A. Di Giambattista, C. Palombi, A. Elad, G. Stradaioli, P. Pascolo, M. Monaci.** 2010. Improving calving management to further enhance reproductive performance in dairy cattle. *Vet. Res. Commun.* 34: 37–40.

**Rexha, S., E. Grunert.** 1993. The forecasting of the time of calving using a rapid progesterone test. *Tierärztliche Praxis* 21: 197–200.

**Shah, K. D., T. Nakao, H. Kubota, T. Maeda.** 2007. Peripartum changes in plasma estrone sulphate and estradiol-17beta profiles associated with and without the retention of fetal membranes in Holstein-Friesian cattle. *J. Reprod. Develop.* 53(2): 279–288.

**Streyl, D., C. Sauter-Louis, A. Braunert, D. Lange, F. Weber, H. Zerbe.** 2011. Establishment of a standard operating procedure for predicting the time of calving in cattle. *J. Vet. Sci. (Suwon-si, Korea)* 12(2): 177–185.

**Wright, I. A., I. R. White, A. J. Russel, T. K. Whyte, A. J. McBean.** 1988. Prediction of calving date in beef cows by real-time ultrasonic scanning. *Vet. Rec.* 123(9): 228–229.



## **CHAPTER 5**

# **Evaluation of the performance of the first automatic milking system for buffaloes**

Published in:  
*Journal of Dairy Science (2014) 97:1491–1498*



## 5. Evaluation of the performance of the first automatic milking system for buffaloes

AUTHORS: M. Caria ,\* F. M. Tangorra ,† S. Leonardi ,† V. Bronzo ,† L. Murgia,\* and A. Pazzona \*

\* *Dipartimento di Agraria, Sezione di Ingegneria del territorio, Università degli Studi di Sassari, 07100 Sassari, Italy*

† *Dipartimento di Scienze Veterinarie per la Salute, la Produzione Animale e la Sicurezza Alimentare (VESPA), Università degli Studi di Milano, 20133 Milano, Italy*

### 5.1 Abstract

The objective of this study was to evaluate the response of buffaloes to automatic milking, examining the relationships between milking interval, milk production, and milking time for this species. A total of 7,550 milking records from an average of 40 buffaloes milked by an automatic milking system (AMS) were analyzed during a 3-mo experimental period at a commercial farm with Italian Mediterranean buffaloes in southern Italy. Date and time of animal identification, milk yield, milking duration, milking interval, and average milk flow rate were determined for each milking. The results were also used to predict the maximum number of milkings per day and the optimal number of buffaloes per AMS for different levels of milk production. The average interval period between 2 consecutive milkings was 10.3 h [standard deviation (SD) 3.3]. Overall, 3.4 and 25.7% of the milkings had an interval of  $\leq 6$  h or  $> 12$  h, respectively. Milking duration averaged 8.3 min per buffalo per milking (SD 2.7). The average milk flow rate was 1.3 kg/min (SD 0.5) at a milk yield of 2.8 kg per milking (SD 1.4). Assuming that the milking station is occupied 80% of the time, the number of milkings ranged from 136 to 152 per day and the optimal number of buffaloes per AMS ranged from 59 to 66 when the production level increased from 2 to 5 kg of milk per milking. Automatic milking systems are suitable for buffalo, opening new options for the management of dairy buffalo farms.

Key words: automatic milking system , dairy buffalo , milking performance

## 5.2 Introduction

Automatic milking systems (AMS) were a revolutionary innovation in dairy cow farming and can be seen not only as replacements for milking parlors but also as a new way of managing dairy farms. The first AMS were installed in the Netherlands in 1992, even though interest in fully automated milking began in the 1970s. This interest was initially due to increasing costs of labor, land, buildings, and machinery, combined with decreasing milk prices (de Koning et al., 2002; de Koning and Rodenburg, 2004). By 2009, about 8,000 farms had adopted AMS (Svennersten-Sjaunja and Pettersson, 2008; de Koning, 2010) and AMS can now be considered a well-established technology. About 90% of AMS are installed in dairy farms in northern Europe, whereas the remainder are located in Canada (9%) and the United States (1%) (de Koning, 2010). The slow adoption of AMS in the United States may be due to farmer uncertainty about using the new technology; the lack of readily available support services in the event of mechanical or technical problems; the availability of less-expensive labor compared with other countries; and a higher proportion of large farms, where installing AMS may be less economically advantageous than in the smaller farms of northern Europe (Rotz et al., 2003; Jacobs and Siegford, 2012).

The main factors promoting the adoption of AMS for dairy cows are better organization of labor, increased milk yields, and improved animal behavior (Hogeveen et al., 2001). Automatic milking systems reduce the heavy workload of milking and enable milking frequency to be controlled on an individual cow basis, according to her production level or stage of lactation, without incurring extra labor costs (Hogeveen et al., 2001; Svennersten-Sjaunja and Pettersson, 2008; Jacobs and Siegford, 2012). All else being equal, cows milked more frequently throughout a lactation usually produce greater amounts of milk compared with cows milked twice a day (Stelwagen et al., 2013; Wright et al., 2013). Some researchers have observed an increase in milk production of up to 12% for cows milked more than twice a day in AMS compared with cows milked twice a day in conventional milking systems (de Koning et al., 2002; Wagner-Storch and Palmer, 2003; Wade et al., 2004), whereas other researchers have reported no increase in milk production in cows milked more frequently by AMS (Speroni et al., 2006; Gygax et al., 2007). Although many factors affect the welfare of dairy cows on a farm, cows milked by AMS can manage their daily activities with more freedom and have more opportunities to interact with their environment (Jacobs and Siegford, 2012). Several researchers have compared the behavioral and physiological stress responses of cows during milking in AMS with those being milked in conventional parlor systems. Cows' heart rates in AMS were similar to or lower than those observed in conventional parlors (Hopster et al., 2002; Wenzel et al., 2003; Weiss et al., 2004; Hagen et al., 2005).

Lower maximum plasma adrenaline and noradrenaline concentrations were reported in cows milked in AMS compared with cows milked in conventional parlor systems, which indicates that cows experienced less stress during AMS milking (Hopster et al., 2002). Levels of milk cortisol and fecal corticosteroids did not differ between AMS and conventionally milked cows (Weiss et al., 2004; Gygax et al., 2006; Lexer et al., 2009).

In recent years, buffalo dairy farming in Italy has undergone a marked increase. There are currently about 358,000 head of buffalo on 2,500 farms (ISTAT, 2010), mainly in the center and south of the country (Lazio, Campania, and Apulia). In Italy, buffaloes have been successfully milked by machine for over 30 yr, and this was the main means to increase productivity and improve milk quality. However, because cows and buffaloes are similar species, the experience gained and technologies developed for dairy cattle have usually been applied without alteration for buffaloes, even though the anatomy and physiology of the 2 species differ (Caria et al., 2011). Dairy cows store less than 30% of the total milk yield volume in the udder cistern after a normal milking interval (Ayadi et al., 2003). In dairy buffaloes, only about 5% of the milk produced between 2 consecutive milkings (10- to 12-h interval) is stored in the udder cistern, whereas the remaining 95% of the milk is stored in the alveolar compartment. As a result, premilking stimulation is extremely important for the optimal milk ejection response in buffaloes (Thomas et al., 2004). Moreover, dairy buffaloes have longer and thicker teats compared with dairy cows, which is important to consider when milking buffaloes with a machine (Thomas, 2004). Following the same logic, the automatic milking of dairy buffaloes was introduced for the first time on a commercial farm located in southern Italy (Campania) in 2008. As observed in dairy cows, buffaloes can visit the AMS voluntarily. Consequently, one might expect large variation in the frequency of visits to the milking robot and thus large variations in the milking interval (Hogeveen et al., 2001).

The aims of this study were to evaluate the response of buffaloes to automatic milking and, in particular, the relationships between milking interval, milk production, and milking time for this species.

### **5.3 Materials and methods**

Data were collected during a 3-mo period (December 2010 to February 2011) at a commercial farm with Italian Mediterranean buffaloes in southern Italy (Campania). The farm had 200 dairy buffaloes that were milked automatically in 4 milking stalls (VMS, DeLaval, Tumba, Sweden), each serving 1 pen of buffaloes. Dairy buffaloes were housed in mat-lined free stalls and were fed ad libitum with a TMR provided once a day (07:30 to 09:00 h) and pushed into the

feeding trough twice daily. Guided cow traffic was achieved by using a preselection gate controlled by the AMS. The buffaloes that were allowed to be milked could enter the waiting area facing each AMS and then move to the milking box; otherwise, they were rejected and directed to the feeding area. However, during the period of the study, we set no minimum time interval between milkings. Thus, buffaloes could access the robot at any time to be milked. The AMS installed (VMS, DeLaval) used the standard configuration for dairy cows. The only modification was the installation of a steel casing to protect the electronic components inside the milking box from damage by the horns of the animals.

Data collection was limited to VMS1 (1 of the 4 VMS installed in the farm). During the experimental period, the herd managed by VMS1 consisted of, on average, 40 buffaloes, with 228 DIM and 3.18 lactations. The working parameters were 42 kPa vacuum, 60 cycles/min pulsator rate, and 60% pulsator ratio. The concentrate feed administered in the milking station to each buffalo ranged between 0.5 and 3.0 kg/d based on daily milk yield.

### *5.3.1 Data Collection*

The following information was collected for each milking, using the VMS herd management software (DeLaval DelPro, DeLaval): buffalo identification number, date and time of buffalo identification, milk yield (kg/milking), milking duration (time between the buffalo identification and the last teat-cup detachment, min), and milking interval (time between the beginning of 2 consecutive milkings for the same buffalo, h). The average milk flow rate (kg/min) was calculated as the sum of the milk flow of each quarter.

### *5.3.2 Data Selection and Statistical Analysis*

Before analysis, data were checked for consistency and validity. Data with a milking interval of <1 h or >24 h, in accordance with Hogeveen et al. (2001), were discarded, as were data for yields of <0.5 kg. A total of 7,550 milking records from different buffaloes were used in the present study.

Descriptive statistics (arithmetic average, standard deviation, minimum, and maximum) were calculated for milk yield, milking duration, milking interval, and milk flow rate. The variations in the parameters were also analyzed by evaluating frequency distributions. The variables milk yield, milking duration, milking interval, number of milkings, and average milk flow rate had skewed distributions. Spearman rank correlations ( $r_s$ ) and simple linear regressions were calculated from SPSS software (version 15.0, SPSS Inc., Chicago, IL).

## 5.4 Results and discussion

Table 1 shows the statistical data for the samples in the experiment. The average time interval between consecutive milkings was 10.3 h, greater than that found by de Koning and Ouweltjes (2000) and Hogeveen et al. (2001) for cows (9.2 h), as well as those found in other studies. Jacobs and Siegford (2012), for example, reported in their review article that the most frequent milking interval for cows was between 7 and 8 h. In the current study, a wide distribution in milking frequency was observed. In 71% of cases, the interval was between 6 and 12 h (Figure 1), which is very close to the value of 67% for the time interval reported by Gygax et al. (2007). Only 3.4% of the milkings occurred after an interval of  $\leq 6$  h and 25.7% occurred after  $>12$  h. These results are similar to those reported for milking cows (de Koning and Ouweltjes, 2000; Gygax et al., 2007).

Overall, 21.4% of the buffaloes had a milking frequency  $\geq 2.5$  times a day and 3.6% of had a milking frequency  $\leq 2.0$  times/d. A milking frequency of 2.4 milkings/d was most common (25.0% of cases), as can be seen in Figure 2. These values are similar to those for milking cows, where the average milking frequency varied between 2.3 and 2.8 (de Koning and Ouweltjes, 2000; Wendl et al., 2000).

In 49.5% of cases, average milk flow was between 1 and 1.5 kg/min (Figure 3). This is very different from the 2.1 to 2.5 kg/min found for cows (de Koning and Ouweltjes, 2000). This difference may be because buffalo milk production is lower ( $2.8 \pm 1.4$  kg/buffalo per milking) than that of cows ( $11.8 \pm 4.3$  kg/cow per milking; de Koning and Ouweltjes, 2000). In addition, morphological differences indicate some peculiarities in milk letdown in buffaloes: the total cistern volume and milk cisternal fraction in dairy buffaloes are smaller than those in dairy cows. Animals with small cisterns, such as buffaloes, are more susceptible to the short-term autocrine inhibition of milk secretion, where the presence of milk in large quantities in the secretory tissue leads to reduced milk secretion (Thomas, 2009). In the absence of the milk cisternal fraction, if the milking unit is applied before milk ejection, the teats are exposed to the vacuum that enters the teat canal and milk ducts, causing their collapse. This effect prevents further milk flow, increasing the milking time (Bruckmaier and Blum, 1996; Thomas, 2009). Borghese et al. (2007) reported teat lengths from 6.3 to 8.5 cm for the Mediterranean Buffalo breed and, according to Thomas et al. (2004), milk ejection causes more than a 10% increase in teat length and teat girth. Thomas et al. (2004) also found that teat canals were longer in buffaloes (3.1 cm) than that reported by other researchers for cows (0.5–1.3 cm; Geishäuser and Querengässer, 2000; Neijenhuis et al., 2001). Nevertheless, in a recent study, Ambord et al. (2010) observed that a 3-min manual stimulation before teat-cup attachment reduced teat canal length and milk flow occurred between 16 and 38

kPa, whereas, without prestimulation, no milk could be withdrawn with a vacuum up to 39 kPa. However, no significant correlation was found between the vacuum required to open the teat canal and teat canal length. Ambord et al. (2010) showed that the tissue above the teat canal provides additional teat closure before milk ejection, falsely increasing the teat canal length. The milk flow results for the second most typical group in our study (<1 kg/min; 30.7% of cases) were similar to those reported for conventional milking of buffaloes by Caria et al. (2011, 2012). They found that, even with different operating vacuum levels, the average flow rate was always <1 kg/min. Finally, average flows of between 2.0 and 2.5 kg/min, which are typical for cows, were only found in 16.6% of cases in the current study.

The average milking duration was  $8.3 \pm 2.7$  min/milking, with a frequency of 47.8% for values  $>6$  and  $\leq 9$  min (Figure 4). The high milking duration, substantially greater than that found by André et al. (2010) for cows (5.5 to 6.8 min), is probably due to the greater time needed to extract the milk, even though production is lower. Because of their slow milk ejection reflex and thicker sphincter muscle around the streak canal compared with dairy cows, dairy buffaloes are known to be slow and hard to milk: the lag time before milk let-down ranges from 1.6 to 6.3 min (Costa and Reinemann, 2004; Thomas et al., 2005; Bava et al., 2007; Caria et al., 2011), whereas the lag time from the start of teat stimulation until onset of milk ejection in dairy cows ranges from 40 s to  $>2$  min and increases with a decreasing degree of udder filling (Bruckmaier et al., 1994; Bruckmaier and Hilger, 2001).

Our results confirm those of other studies on buffaloes (Borghese et al., 2007; Caria et al., 2011). Milk yield and average flow rate were positively correlated ( $r_s = 0.53$ ,  $P < 0.01$ ; Table 2), even though variations in milk emissions, even in the same animal, mean that milkings generally take a long time because flow rates are low (Caria et al., 2012). In contrast, we observed a weak negative correlation between the above parameters and milking duration. This suggests that the less-productive buffaloes are also those that are most difficult to milk.

We also observed a significant relationship, albeit very weak, between milking duration, the number of lactations ( $r_s = 0.16$ ,  $P < 0.01$ ), and DIM ( $r_s = -0.12$ ,  $P < 0.01$ ; Table 2). A reduction in total milking time as the stage of lactation increased was also observed in dairy buffaloes milked in conventional milking parlors (Bava et al., 2007). This is probably due to the reduction in cistern size and milk yield as lactation progresses (Thomas et al., 2004) and to the delay of alveolar milk ejection due to the decrease in udder filling (Bruckmaier and Hilger, 2001). However, no relationship was found between the milking duration and milking interval. This indicates that the average time taken to milk an animal did not influence the daily number of milkings. This result may, however, have been influenced by the number of buffaloes using the AMS station ( $40 \pm 5.51$ ).



The farmer had, indeed, deliberately reduced the number of animals assigned to each AMS station so that all the buffaloes could be milked correctly. We found a very weak relationship between milk yield and milking interval ( $r_s = 0.08$ ,  $P < 0.01$ ) but none between milking interval and average milk flow rate, which contrasts with results for cows, where long milking intervals are associated in an increase in milk flow, irrespective of the level of milk production (Hogeveen et al., 2001). Yield per milking and average flow rate were positively correlated with DIM ( $r_s = 0.10$ ,  $P < 0.001$ ;  $r_s = 0.23$ ,  $P < 0.001$ ; Table 2) and the number of milkings ( $r_s = 0.19$ ,  $P < 0.001$ ;  $r_s = 0.16$ ,  $P < 0.001$ ). We found a negative relationship between milking interval, the number of milkings ( $r_s = -0.25$ ,  $P < 0.001$ ), and DIM ( $r_s = 0.20$ ,  $P < 0.001$ ), as is also the case for cows (Dzidic et al., 2004; Jacobs and Siegford, 2012).

Our results showed a good coefficient of determination for the 3 linear regressions calculated here (Figures 5,6, and 7). The daily yield determined the amount of time that the AMS was used daily ( $R^2 = 0.83$ ,  $P < 0.001$ ).

Increasing the daily yield per station was conditioned by the number of times per day that buffaloes used an AMS station ( $R^2 = 0.87$ ,  $P < 0.001$ ), as has been reported in many studies on cows (de Koning et al., 2002; Wagner-Storch and Palmer, 2003; Wade et al., 2004; Melin et al., 2005). The increase in the number of daily visits to the AMS was significantly correlated with the number of animals per AMS station ( $R^2 = 0.72$ ,  $P < 0.001$ ).

#### *5.4.1 Number of Milkings per Day and Daily Production*

The results were used to calculate the maximum number of milkings per day and the optimal number of buffaloes per AMS for a determined level of milk production. This was done using the average milking duration per milking for each production level (from 2 to 5 kg/milking) and with the milking station being occupied for 80% of the time (Table 3) (Rossing et al., 1997; de Koning and Ouweltjes, 2000).

To calculate the potential number of milkings per day, the occupation rate was multiplied by 1,440/milking duration per visit, where the occupation rate is the percentage of 24 h that the AMS is used for milking and the milking duration per visit is the time between the identification of the buffalo and the removal of the last teat cup.

When the average production of the buffaloes was 2 kg/milking, the maximum number of milkings per AMS station was 136 per day (Table 3), whereas when average production was 4 kg/milking, the number of milkings increased to 152 per day (an increase of 12%). This result is different from the results estimated for cows by de Koning and Ouweltjes (2000). They found that increased yield also increased the total time spent at the milking station, with a resulting decrease in the number of daily milkings. The lower number of daily milkings

with low-yield buffaloes may be due to the major lag time before milk ejection (period between teat-cup attachment and the start of milk ejection) for the latter. The lag time tends to increase as the stage of lactation increases (Bava et al., 2007), when both milk yield and cistern size are reduced (Thomas et al., 2004). However, milkings with an average yield of 2 kg mean that the daily milk production per milking station is modest (271.8 kg/d). If the average yield per milking were doubled to 4 kg, then total milk production would increase to 609.6 kg/d (an increase of 337.8 kg/d).

The results we obtained may be useful for estimating the maximum number of buffaloes per AMS station. In Table 3, the maximum number of milkings per day (152) was divided by the average milkings per buffalo per day to calculate the number of buffaloes per AMS station at an 80% occupation rate. Thus, if the average number of milkings per buffalo per day is 2.3 (from the average values obtained in this work), then the maximum number of buffaloes that can be milked by the AMS station is 66.

In regard to the economics of an AMS, it is possible to compare the milk revenue of buffalo and cow AMS because the operating costs of the equipment are the same. With a yield of 435.9 kg of milk/d per AMS at an 80% occupation rate (Table 3) and a buffalo milk price of €1.23/L (ISMEA, 2007), milk revenue would be €536/d. André et al. (2010), at the same occupation rate (80%) and considering optimal individual intervals for the animals, obtained €525/d of milk revenue per AMS in cows. Thus, the pay back [the length of time required to recover the investment (payback period = cost of investment/annual cash inflows)] of AMS does not differ much between buffaloes and cows. As for dairy cows, the choice to adopt an AMS in buffalo farms must consider not only economic aspects, but also the adaptability of the herd.

## 5.5 Conclusions

Voluntary AMS are suitable for dairy buffaloes. The frequency distribution of milking intervals and average milking frequency were similar to those reported for milking cows. As expected, milk yield and flow rate were lower and milking time longer compared with those for dairy cows. Nonetheless, our results are comparable with the results for buffaloes milked using conventional systems. Thus, AMS may be a promising alternative to conventional mechanical milking for buffaloes, opening new options for the management of dairy buffalo farms.

## 5.6 References

- Ambord, S., M. H. Stoffel, and R. M. Bruckmaier.** 2010. Teat anatomy affects requirements for udder preparation in Mediterranean buffaloes. *J. Dairy Res.* 77:468–473.
- André, G., P. B. M. Berentsen, B. Engel, C. J. A. M. de Koning, and A. G. J. M. Oude Lansink.** 2010. Increasing the revenues from automatic milking by using individual variation in milking characteristics. *J. Dairy Sci.* 93:942–953.
- Ayadi, M., G. Caja, X. Such, and C. H. Knight.** 2003. Use of ultrasonography to estimate cistern size and milk storage at different milking intervals in the udder of dairy cows. *J. Dairy Res.* 70:1–7.
- Bava, L., A. Sandrucci, A. Tamburini, and M. Zucali.** 2007. Milk flow traits of buffalo cows in intensive farming system. *Ital. J. Anim. Sci.* 6:500–502.
- Borghese, A., M. Rasmussen, and C. S. Thomas.** 2007. Milking management of dairy buffaloes. *Ital. J. Anim. Sci.* 6:39–50.
- Bruckmaier, R. M., and J. W. Blum.** 1996. Simultaneous recording of oxytocin release, milk ejection and milk flow during milking of dairy cows with and without prestimulation. *J. Dairy Res.* 63:201–208.
- Bruckmaier, R. M., and M. Hilger.** 2001. Milk ejection in dairy cows at different degrees of udder filling. *J. Dairy Res.* 68:369–376.
- Bruckmaier, R. M., D. Schams, and J. W. Blum.** 1994. Continuously elevated concentrations of oxytocin during milking are necessary for complete milk removal in dairy cows. *J. Dairy Res.* 61:323–334.
- Caria, M., C. Boselli, L. Murgia, R. Rosati, and A. Pazzona.** 2012. Effect of vacuum level on milk flow traits in Mediterranean Italian buffalo cow. *Ital. J. Anim. Sci.* 11:137–139.
- Caria, M., L. Murgia, and A. Pazzona.** 2011. Effects of the working vacuum level on mechanical milking of buffalo. *J. Dairy Sci.* 94:1755–1761.
- Costa, D. A., and D. J. Reinemann.** 2004. The purpose of the milking routine and comparative physiology of milk removal. *Pages 189–197 in Proc. Natl. Mastitis Council Annu. Mtg.*, Charlotte, NC. National Mastitis Council, Verona, WI.

**de Koning, K.** 2010. Automatic milking—Common practice on dairy farms. *Pages V59–V63 in Proc. Second North Am. Conf. Robotic Milking*, Toronto, Canada. Precision Dairy Operators, Elora, ON, Canada.

**de Koning, K., and W. Ouweltjes.** 2000. Maximising the milking capacity of an automatic milking system. *Pages 38–46 in Proc. Int. Symp. Robotic Milking*, Lelystad, the Netherlands. Wageningen Academic Publishers, Wageningen, the Netherlands.

**de Koning, K., and J. Rodenburg.** 2004. Automatic milking: State of the art in Europe and North America. *Pages 27–35 in Automatic Milking: A Better Understanding*. A. Meijering, H. Hogeveen, and C. J. A. M. de Koning, ed. Wageningen Academic Publishers, Wageningen, the Netherlands.

**de Koning, K., Y. van der Vost, and A. Meijering.** 2002. Automatic milking experience and development in Europe. *Pages I1–I11 in Proc. First North Am. Conf. Robotic Milking*, Toronto, Canada. Wageningen Academic Publishers, Wageningen, the Netherlands.

**Dzidic, A., D. Weiss, and R. M. Bruckmaier.** 2004. Oxytocin release, milk ejection and milking characteristics in a single stall automatic milking system. *Livest. Prod. Sci.* 86:61–68.

**Geishauser, T., and K. Querengässer.** 2000. Investigation on teat canal lengths in teats with milk flow disturbances. *J. Dairy Sci.* 38:1976–1980.

**Gygax, L., I. Neuffer, C. Kaufmann, R. Hauser, and B. Wechsler.** 2006. Milk cortisol concentration in automatic milking systems compared with auto-tandem milking parlors. *J. Dairy Sci.* 89:3447–3454.

**Gygax, L., I. Neuffer, C. Kaufmann, R. Hauser, and B. Wechsler.** 2007. Comparison of functional aspects in two automatic milking systems and auto-tandem milking parlors. *J. Dairy Sci.* 90:4265–4274.

**Hagen, K., J. Langbein, C. Schmied, D. Lexer, and S. Waiblinger.** 2005. Heart rate variability in dairy cows—Influences of breed and milking system. *Physiol. Behav.* 85:195–204.

**Hogeveen, H., W. Ouweltjes, C. J. A. M. de Koning, and K. Stelwagen.** 2001. Milking interval, milk production and milk flowrate in an automatic milking system. *Livest. Prod. Sci.* 72:157–167.

**Hopster, H., R. M. Bruckmaier, J. T. N. Van der Werf, S. M. Korte, J. Macuhova, G. Korte-Bouws, and G. van Reenen.** 2002. Stress responses during milking: Comparing conventional and automatic milking in primiparous dairy cows. *J. Dairy Sci.* 85:3206–3216.

**ISMEA.** 2007. Istituto di servizi per il mercato agricolo alimentare (ISMEA)—Analisi del costo e della redditività della produzione di latte di bufala—Indagine 2007. Accessed Dec. 26, 2013. <http://www.ismea.it/flex/cm/pages/ServeBLOB.php/L/IT/IDPagina/2855>.

**ISTAT.** 2010. Istituto nazionale di statistica (ISTAT)—6° General census of agriculture (provisional data). Accessed Dec. 26, 2013. <http://dati-censimentoagricoltura.istat.it/>.

**Jacobs, J. A., and J. M. Siegford.** 2012. Invited review: The impact of automatic milking systems on dairy cow management, behavior, health, and welfare. *J. Dairy Sci.* 95:2227–2247.

**Lexer, D., K. Hagen, R. Palme, J. Troxler, and S. Weiblinger.** 2009. Time budgets and adrenocortical activity of cows milked in a robot or a milking parlour: Interrelationships and influence of social rank. *Anim. Welf.* 18:73–80.

**Melin, M., K. Svennersten-Sjaunja, and H. Wiktorsson.** 2005. Feeding patterns and performance of cows controlled cow traffic in automatic milking systems. *J. Dairy Sci.* 88:3913–3922.

**Neijenhuis, F., G. H. Klungel, and H. Hogeveen.** 2001. Recovery of cow teats after milking as determined by ultrasonographic scanning. *J. Dairy Sci.* 84:2599–2606.

**Rossing, W., P. H. Hogewerf, A. H. Ipema, C. C. Ketelaar De Lauwere, and C. J. A. M. deKoing.** 1997. Robotic milking in dairy farming. *Neth. J. Agric. Sci.* 45:15–31.

**Rotz, C. A., C. U. Coiner, and K. J. Soder.** 2003. Automatic milking systems, farm size, and milk production. *J. Dairy Sci.* 86:4167–4177.

**Speroni, M., G. Pirlo, and S. Lolli.** 2006. Effect of automatic milking systems on milk yield in a hot environment. *J. Dairy Sci.* 89:4687–4693.

**Stelwagen, K., C. V. Phyn, S. R. Davis, J. Guinard-Flament, D. Pomiès, J. R. Roche, and J. K. Kay.** 2013. Invited review: Reduced milking frequency: Milk production and management implications. *J. Dairy Sci.* 96:3401–3413.

**Svennersten-Sjaunja, K. M., and G. Pettersson.** 2008. Pros and cons of automatic milking in Europe. *J. Anim. Sci.* 86:37–46.

**Thomas, C. S.** 2004. Milking management of dairy buffaloes. *PhD Thesis.* Department of Animal Nutrition and Management, Swedish University of Agricultural Sciences, Uppsala, Sweden.

**Thomas, C. S.** 2009. Housing and management of lactating buffaloes. *Pages 11–26 (CD-ROM) in Proc. Europe and America’s Buffalo Symp.*, Pedro Leopoldo, Brazil. Colégio Brasileiro de Reprodução Animal (CBRA), Belo Horizonte, Brazil.

**Thomas, C. S., R. M. Bruckmaier, K. Ostensson, and K. SvennerstenSjaunja.** 2005. Effect of different milking routines on milking-related release of the hormones oxytocin, prolactin and cortisol, and on milk yield and milking performance in Murrah buffaloes. *J. Dairy Res.* 72:10–18.

**Thomas, C. S., K. Svennersten-Sjaunja, M. R. Bhosrekar, and R. M. Bruckmaier.** 2004. Mammary cisternal size, cisternal milk and milk ejection in Murrah buffaloes. *J. Dairy Res.* 71:162–168.

**Wade, K. M., M. A. P. M. van Asseldonk, P. B. M. Berentsen, W. Ouweltjes, and H. Hogeveen.** 2004. Economic efficiency of automatic milking systems with specific emphasis on increases in milk production. *Pages 62–67 in Automatic Milking: A Better Understanding.* A. Meijering, H. Hogeveen, and C. J. A. M. de Koning, ed. Wageningen Academic Publishers, Wageningen, the Netherlands.

**Wagner-Storch, A. M., and R. W. Palmer.** 2003. Feeding behavior, milking behavior, and milk yields of cows milked in a parlor versus automatic milking system. *J. Dairy Sci.* 86:1494–1502.

**Weiss, D., S. Helmreich, E. Möstl, A. Dzidic, and R. M. Bruckmaier.** 2004. Coping capacity of dairy cows during the change from conventional to automatic milking. *J. Anim. Sci.* 82:563–570.

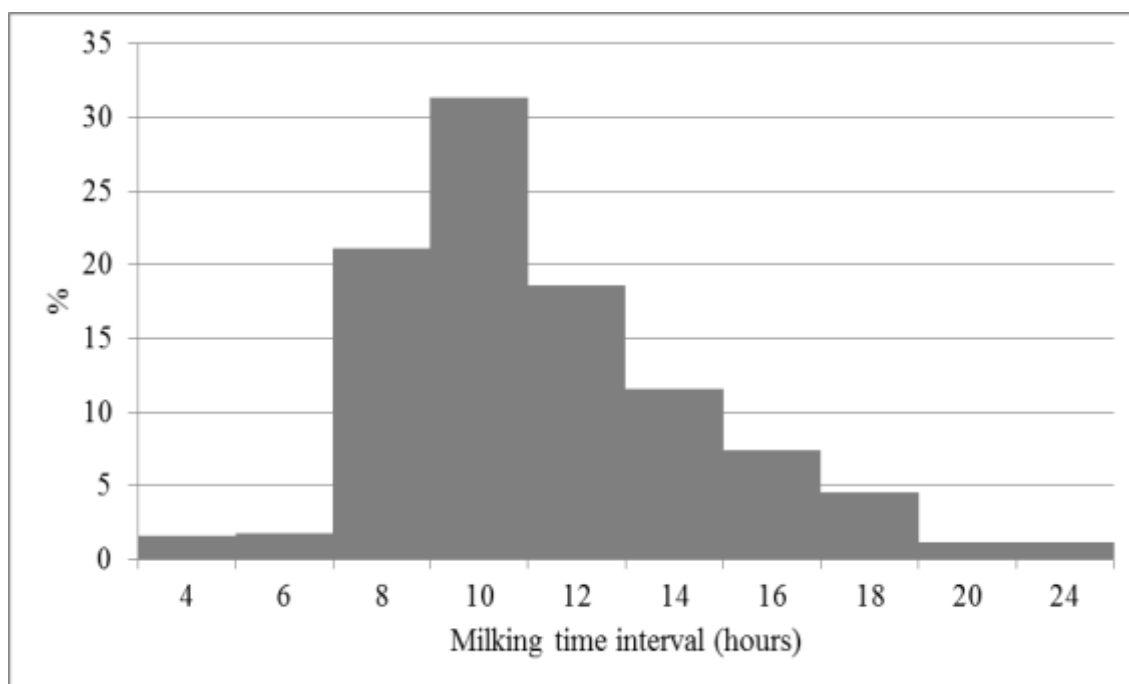
**Wendl, G., J. Harms, and H. Schön.** 2000. Analysis of milking behavior on automatic milking. *Pages 143–151 in Proc. Int. Symp. Robotic Milking,* Lelystad, the

Netherlands. H. Hogeveen and A. Meijering, ed. Wageningen Academic Publishers, Wageningen, the Netherlands.

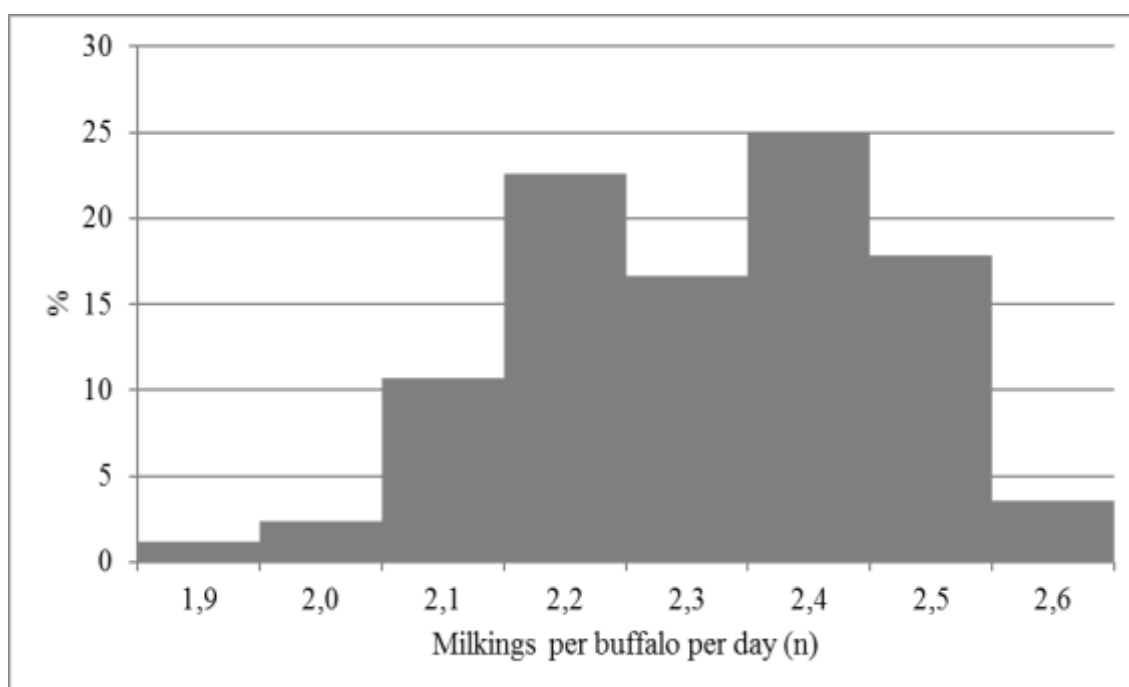
**Wenzel, C., S. Schönreiter-Fischer, and J. Unshelm.** 2003. Studies on step-kick behavior and stress of cows during milking in an automatic milking system. *Livest. Prod. Sci.* 83:237–246.

**Wright, J. B., E. H. Wall, and T. B. McFadden.** 2013. Effects of increased milking frequency during early lactation on milk yield and udder health of primiparous Holstein heifers. *J. Anim. Sci.* 91:195–202.

## 5.7 List of figures

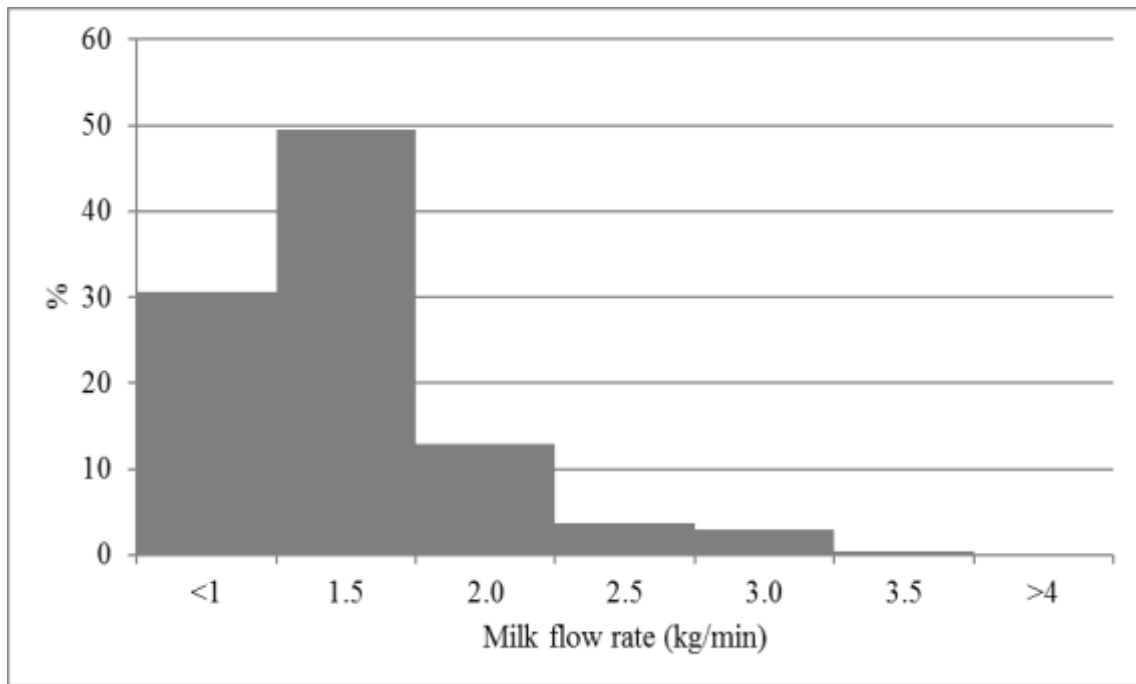


**Figure 1.** Frequency distribution of all milking intervals (time between the beginning of 2 consecutive milkings for the same buffalo, in hours) for the herd of buffalo managed by AM-system (period December 2010 – February 2011)

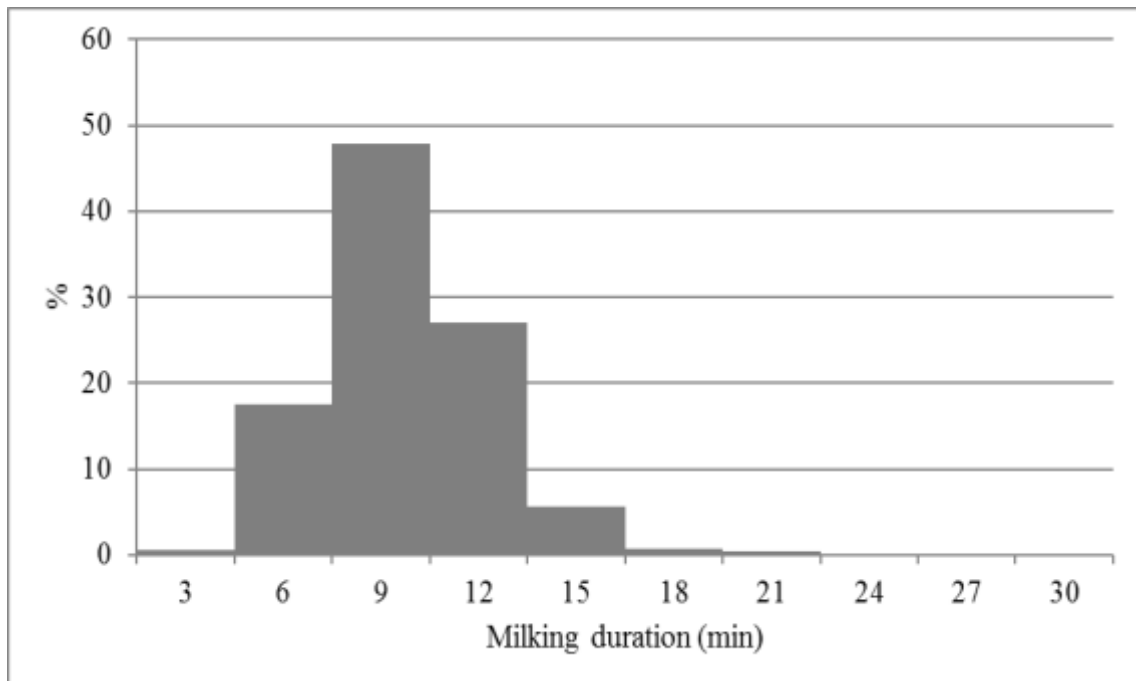


**Figure 2.** Frequency distribution of average number of milkings per buffalo per day for the herd managed by AM-system (period December 2010 – February 2011)

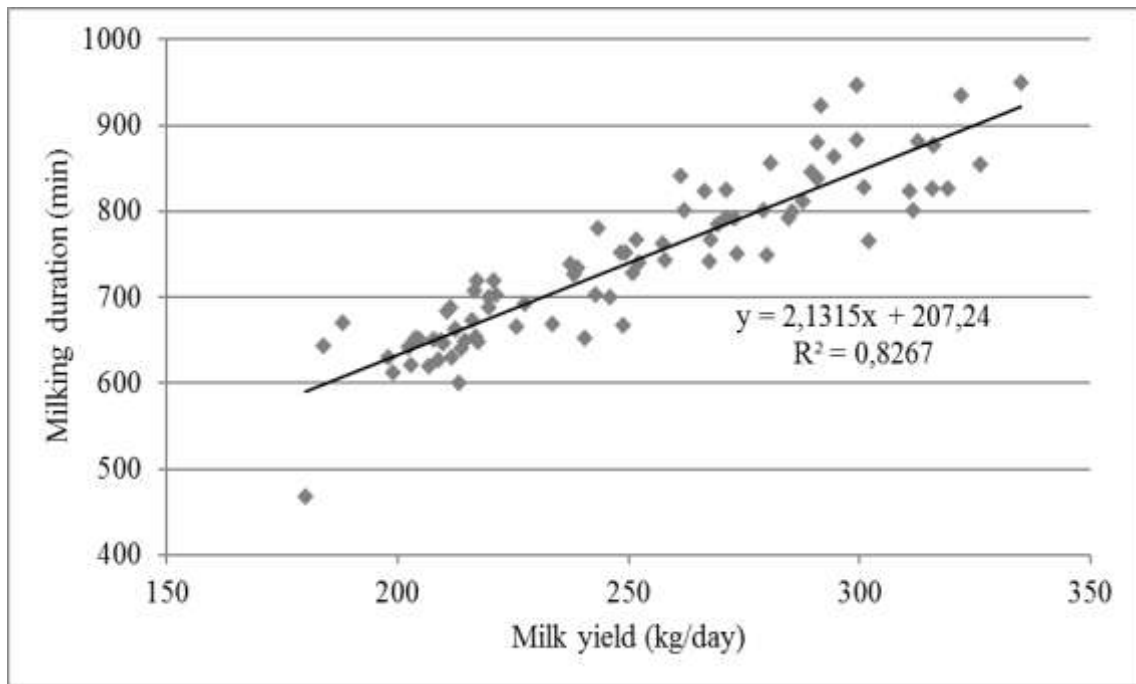




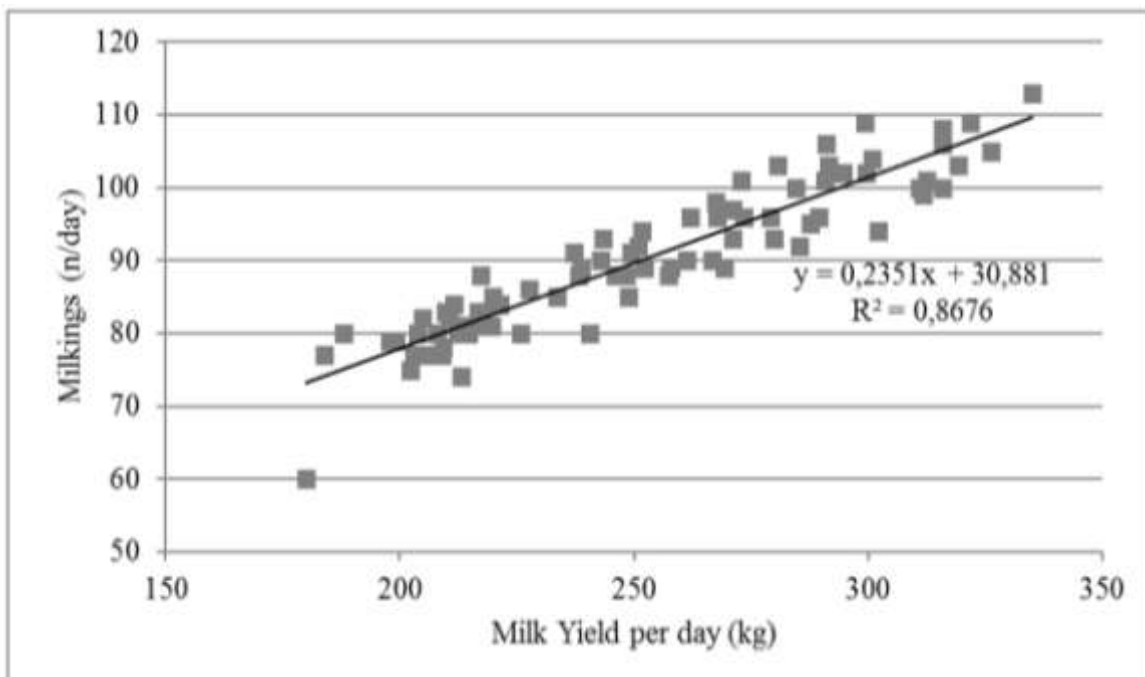
**Figure 3.** Frequency distribution of average milk flow rates for buffaloes managed by AM-system (period December 2010 – February 2011)



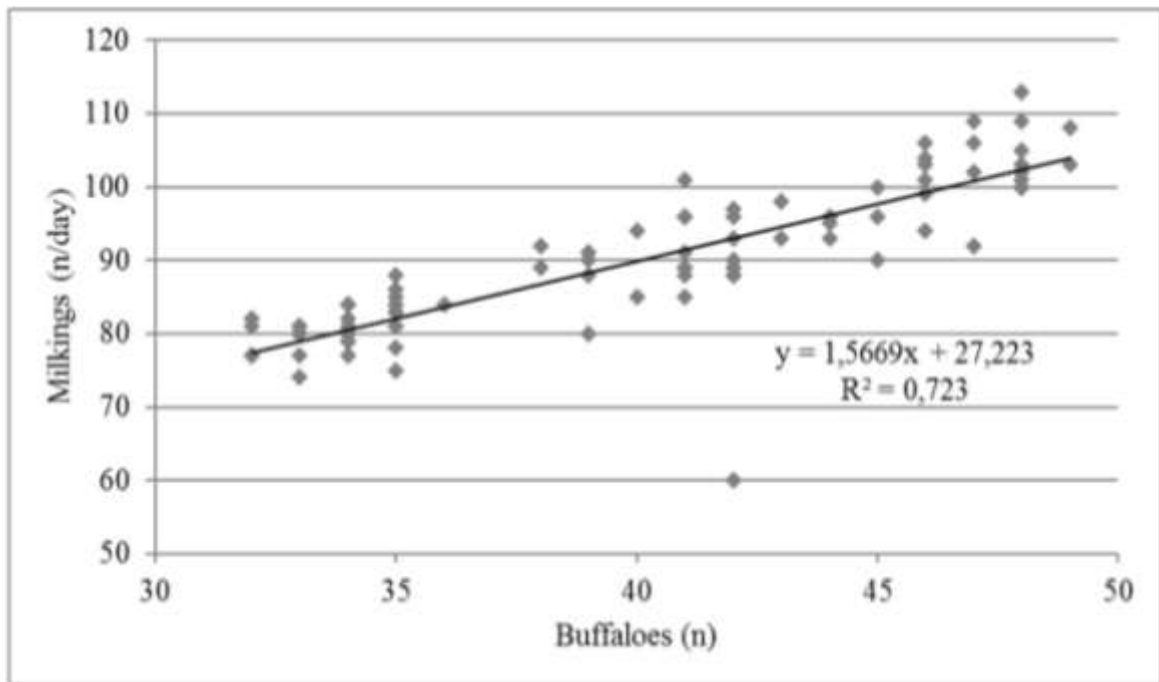
**Figure 4.** Frequency distribution of milking duration (time between the buffalo identification and the last teat-cup detachment) per buffalo per milking for the herd managed by AM-system (period December 2010 – February 2011)



**Figure 5.** Relationships between milk yield per day from all the dairy buffaloes milked in AM-system and milking duration (time between the buffalo identification and the last teat-cup detachment) per day ( $P < 0.001$ )



**Figure 6.** Relationships between milkings per day and milk yield per day for the herd of buffalo managed by AM-system ( $P < 0.001$ )



**Figure 7.** Relationships between number of buffaloes per AM system and milkings per day for the herd of buffalo managed by AM-system ( $P < 0.001$ )

## 5.8 List of tables

**Table 1.** Descriptive statistics of the data set (herd characteristics, milk yield, milking duration per milking and buffalo, and derived statistics) for the automatic milking (AM) of dairy buffaloes during the experimental period (December 2010 – February 2011)

<b>Variable</b>	<b>Mean</b>	<b>SD</b>
Buffalo per AM <sup>1</sup> system [n]	40	5.5
Days in milking [n]	228	127
Primiparous buffaloes [n]	16	-
Primiparous buffaloes [%]	30.8	-
Parity [n]	3.2	2.1
<b>Per milking</b>		
Milk yield [kg/milking]	2.8	1.4
Milking duration <sup>2</sup> [min/milking]	<b>8.3</b>	2.7
<b>Per buffalo</b>		
Milking interval [h]	<b>10.3</b>	3.3
Milkings [n/buffalo per day]	<b>2.3</b>	0.2
Milk yield [kg/buffalo per day]	<b>6.3</b>	0.4
Duration [min/buffalo per day]	<b>18.6</b>	1.4
Average milk flow rate [kg/min]	<b>1.3</b>	0.5
<b>Use of AM<sup>1</sup> system capacity</b>		
Milkings [n/d]	<b>89.9</b>	10.2
Duration [h/d]	<b>12.1</b>	1.6
Occupation rate [%]	<b>50.3</b>	
Milk yield [kg/d]	<b>251.0</b>	40.2

<sup>1</sup>AM = automatic milking

<sup>2</sup>Time between the buffalo identification and the last teat-cup detachment

**Table 2.** Spearman rank correlations ( $r_s$ ) and statistical significance ( $P$ ) between variables (total number of observations per variable  $N = 7,550$ )

	Milking duration (min)	Average flow rate (kg/min)	Days in milking (n)	Milking interval (h)	Number of lactations (n)	Milk yield (kg)
Milking duration (min)	1.000	-.343(**)	-.119(**)	0.001	.160(**)	-.210(**)
Average flow rate (kg/min)		1.000	.227(**)	-0.006	.165(**)	.531(**)
Days in milking (n)			1.000	.197(**)	-.338(**)	.105(**)
Milking interval (h)				1.000	-.249(**)	.079(**)
Number of lactations (n)					1.000	.190(**)
Milk yield (kg)						1.000

\*\*Correlation is significant at the 0.01 level.

**Table 3.** Flow rate, milking duration, number of milking per day, number of buffaloes per AM system and capacity in kg per day at an occupation rate of 80%

	2	3	4	5
Yield (kg/milking)				
Flow rate (kg/min)	1.10	1.28	1.50	1.72
Milking duration (min)	8.48	7.93	7.56	7.62
Milk yield (kg per day)	271.8	435.9	609.6	756.0
Number of milking per day	136	145	152	151
Number of buffaloes per AMS	59	63	66	66



## CHAPTER 6

# Methods of estimating Liner Compression

Submitted for publication to:  
*Journal of Dairy Science*





## 6. Methods of estimating Liner Compression

AUTHORS: S. Leonardi,\* J. F. Penry,<sup>†</sup> F. M. Tangorra,\* P. D. Thompson,<sup>‡</sup> D. J. Reinemann<sup>‡</sup>

\* *Department of Health, Animal Science and Food Safety, Università degli Studi di Milano, 20133 Milano, Italy*

<sup>†</sup> *Department of Dairy Science, University of Wisconsin, Madison 53706*

<sup>‡</sup> *Department of Biological Systems Engineering, University of Wisconsin, Madison 53706*

### 6.1 Abstract

The aim of this study was to compare two methods of measuring Overpressure (OP) using a new test device designed to make OP measurements more quickly and accurately. OP was measured with no pulsation (OP<sub>np</sub>) and with limited pulsation (OP<sub>lp</sub>) repeatedly on the same cow during a single milking. Each of the six liners (three round liners and three triangular liners) used in this study were tested on the same six experimental cows. OP<sub>np</sub> and OP<sub>lp</sub> were measured on all four teats of each experimental cow twice for each liner. The order of OP<sub>np</sub> and OP<sub>lp</sub> alternated sequentially for each cow test. The OP results for the six liners were also compared to liner compression (LC) estimated on the same liners with a novel artificial teat sensor (ATS).

The OP<sub>lp</sub> method showed small but significantly higher values than the OP<sub>np</sub> method (13.9 kPa vs. 13.4 kPa). The OP<sub>lp</sub> method is recommended as the preferred method as it more closely approximates normal milking condition. OP values decreased significantly between the first and the following measurements, (from 15.0 kPa to 12.4 kPa). We recommend performing the OP test at a consistent time, one minute after attaching the teatcup to a well-stimulated teat, to reduce the variability produced by OP changing during the peak flow period. The new test device had several advantages over previously published methods of measuring OP. A high correlation between OP and LC estimated by the ATS was found, however, difficulties were noted when using the ATS with triangular liners.

Key words: liner compression, overpressure, artificial teat sensor.

## 6.2 Introduction

Vacuum applied to the teat during the milk, or b-phase, of pulsation unfolds the teat canal and allows milk to be removed from the teat sinus. This vacuum also causes blood and other tissue fluids to accumulate in teat tissues. The action of LC, applied during the rest, or d-phase, of pulsation helps to maintain milk flow by re-moving accumulated fluids in teat-end tissues. The LC has been estimated through; 1. experiments with live teats (Thompson, 1978; Mein and Williams, 1984; Gates and Scott, 1986; Mein et al. 1987), 2. artificial teat sensor devices (Caruolo, 1983, Gates and Scott, 1986; Muthukumarappan et al., 1994; Davis et al, 2001; van der Tol, 2010), and 3. mathematical models (Butler, 1993).

The force applied to the teat end by the collapsed liner was described as compressive load by Mein et al. (1987). A more recent definition of Liner Compression (LC) has been proposed by Mein et al. (2003) as the compressive pressure, over and above the pressure of air in the pulsation chamber (PC), which is applied by a liner to the teat apex during the late c-, d- or early a- phases of a pulsation cycle. LC reaches its maximum steady value during the d-phase of the pulsation cycle (Mein and Reinemann, 2009; Reinemann, 2012; Mein et al., 2013).

LC as been shown to influence peak milking speed and the occurrence of teat-end hyperkeratosis (Zucali et al., 2008). LC is a function of the physical dimensions and material properties of the liner in addition to pressure difference applied across the collapsed liner during the d phase of pulsation. It can also be influenced by teat dimension and liner-teat fit (Reinemann, 2012). The difficulties of measuring LC have been reported by Mein et al. (2013).

OverPressure (OP) has been proposed as a robust and practical method to estimate the relative value of LC across liners (Mein et al., 1987, 2003). OP is defined as the pressure difference across the liner at which milk flow just starts or stops. OP is not a direct measure of LC, but can provide a biologically relevant indicator of the relative values of LC, because, in part, it is a method that uses live teats in near milking conditions (Reinemann, 2012; Mein et al., 2013). The original test methodology for OP (Mein et al., 2003) involved removing the short pulse tube from one teat cup (thereby deactivating pulsation) and increasing the vacuum using a hand vacuum pump until milk flow was observed. Gomez (2010) developed a “dynamic” OP method in which the pulsator remained active with vacuum in the PC increased in steps of 2 kPa until milk flow was observed in all quarters of an individual cow. This test method allowed for more rapid collection of OP observations, thus facilitating a large sample size of OP measurements, but required modification of the milking installation. The dynamic method produced OP values lower than the original

OP method (Reinemann, 2012) but these measurements were done on different population of dairy cows.

The aim of this study was to further advance OP test methods by developing a new test device that would allow for OP measurements of four quarters of one cow simultaneously, and without requiring modification of the milking installation. The primary objective was to compare two methods of measuring OP, both with and without active pulsation and to examine differences in OP measurements during the peak flow period. A secondary objective of this study was to compare OP measurements with LC measurements made with a novel artificial teat sensor.

## 6.3 Materials and Methods

### 6.3.1 Overpressure measurements

Two different methods of measuring OP were tested: 1. with no pulsation –  $OP_{np}$  in a way similar to the original OP method (Mein et al., 2003) but with a shorter period of liner collapse and, 2. with limited pulsation –  $OP_{lp}$  in a way similar to the method reported by Gomez (2010) but with finer resolution of measurements. Overpressure was measured as a continuous variable for each teat on each cow with both methods. Tests were performed at the University of Wisconsin-Madison Dairy Cattle Center in a 6+6 parallel milking parlor with low-level milk line, with system vacuum level of 42.3 kPa. Six liners with mouthpiece depth (MPD) ranging from 35 mm to 40 mm were tested: three round liners (A, B, C), and three triangular liners ((D, E, F). Six dairy cows (Holstein-Frisian) with pre-milking teat length between 40 and 50 mm were selected from the herd, so that the teat end would be positioned in the part of the liner that is able to collapse and provide compression, according to Reinemann et al. (2011).

The six cows were distributed across early, mid, and late lactation (54-308 DIM) with a parity range of 1-4, and an average milk yield of  $36.8 \pm 9.9$  kg/cow per day. The average teat length was 46.8 mm with a standard deviation of 6.8 mm. Each liner was tested for one milking on each of the cows selected on six consecutive milkings (four a.m. milkings and two p.m. milkings).

The OP measurements were made using a new test device, the OP Bucket (OPB), designed and built by Milkline s.r.l. (Podenzano, Italy) in collaboration with the Università degli Studi di Milano (Italy). With this device the pulsation chamber vacuum (PCV) at which milk flow starts could be measured on each individual teat. The OPB consisted of a 30-liter milking bucket, equipped with the following automation and pressure regulation components installed on the lid of the bucket (Figure 1).

- digital vacuum sensor (ZSE30-01-25L, SCM Pneumatics, CA, USA) to display the vacuum level in the bucket;
- battery powered servo-pulse pulsator (Milcline s.r.l., Podenzano, Italy)
- needle valve to gradually increase the vacuum level in the bucket;
- valves to connect bucket to vacuum source, atmospheric air, and pulsation tubes.

Cows were prepared for milking by predipping, forestripping, and drying all four quarters. The cluster was attached about 90 s after completion of this preparation procedure. OP measurements were made one minute after the cluster attachment and at one-minute intervals until four OP measurements were completed. The measurement sequence ( $OP_{np}$   $OP_{lp}$   $OP_{np}$   $OP_{lp}$ ) was reversed ( $OP_{lp}$   $OP_{np}$   $OP_{lp}$   $OP_{np}$ ) from one cow to the next.

$OP_{np}$  was measured with the pulsator was turned off and applying a gradual increase in pulsation chamber vacuum (PCV) starting from 0 kPa. The vacuum level at which milk flow was first observed was recorded for each quarter.  $OP_{lp}$  was measured in the same was as  $OP_{np}$ , but with pulsator operating.

### 6.3.2 *Artificial teat sensor*

An artificial teat sensor (ATS) adapted from Davis et al. (2001) was developed to measure liner compression (LC) directly. A resistive force sensor (FlexiForce B201 Sensors, Tekscan Inc., MA, USA) was mounted on flat plastic plate 186 mm long x 2 mm thick x 19 mm wide (with 9.5 mm radius rounded end). The active area of the resistive force sensor was a 9.5 mm diameter disc that was placed so that the end of the active area of the sensor was at the end of the rounded end of the flat plastic plate. The signal from the sensor was shown to respond to bending and shear as well as normally applied force and mount on the flat rigid plate so that it would respond to normally applied force only. The load cell was calibrated using a 4-point method with dead weights over the known active area of the resistive load sensor. The sensor exhibited excellent linearity and repeatability.

The end of the sensor was covered with a 30 long x 19 mm diameter cylinder with spherical cap end molded of silicon gel with a shore-A hardness 10 to approximate the biomechanical properties of teat tissue. The silicon teat apex was the covered with a close fitting latex glove finger to approximate the physical properties of teat skin. The physical properties of the sensor were designed to approximate those of live teats as liner compression has been shown to be influenced by the hardness of artificial teat sensors (Davis et al. (2001)).

LC measurements were done using the ATS on the same six liners used for OP testing. For round liners the ATS was inserted so that the flat center plate of the sensor was aligned with the collapse plane the liner. For triangular liners LC measurements were done with the sensing surface facing a “flat” side of the liner

and then repeated with the sensing surface facing the “corner” of the liner. LC was measured with the teat sensor at an insertion depth of 60 mm in the liner to approximate the position of the teat end for the selected teats, characterized by a pre-milking teat length of 40-50 mm. Measurements were performed at a pressure difference (PD) across the liner (vacuum in the short milk tube) from 30 kPa to 50 kPa in 5 kPa increments.

### 6.3.3 Statistical analysis

Data were analyzed using the SAS version 9.3 system (SAS Institute Inc., Cary, NC). The PROC MIXED procedure was used to test for differences in OP with cow and cow by teat as random effects, cow by teat as repeated effect, and liner, test method, test order, and the interaction of test method by test order, liner by test method, and liner by test order as fixed effects. Terms that were not significant ( $P > 0.05$ ) were removed from the model. The initial model was:

$$Y_{ik} = \mu + TM_i + TO_j + L_k + TM*TO_{ij} + TM*L_{ik} + TO*L_{jk} + TM*TO*L_{ijk} + e_{ik}$$

where  $Y_{ik}$  = OP;  $\mu$  = overall mean;  $TM_i$  = effect of test method ( $i = np, lp$ );  $TO_j$  = effect of test order ( $j = 1-4$ );  $L_k$  = effect of liners ( $k = 1-6$ );  $TM*TO_{ij}$  = interaction test method by test order  $TM*L_{ik}$  = interaction test method by liner;  $TO*L_{jk}$  = test order by liner;  $TM*TO*L_{ijk}$  = interaction test method by test order by liner;  $e_{ik}$  = random error with zero mean and variance.

Results were reported as least squares means, significance was declared at  $P < 0.05$ .

Descriptive statistics of LC data were calculated for each liner and the PROC CORR procedure of SAS 9.3 (SAS Institute Inc., Cary, NC) was used to assess Pearson's correlation coefficients between OP and LC values measured for each liner.

## 6.4 Results and Discussion

### 6.4.1 Overpressure measurements

OP values were recorded as 0.0 kPa for all tests of liner F as milk flow was present for all quarters for when PCV was 0 kPa (atmospheric pressure) for all tests. As there was no variability in OP associated with Liner F, it was not included in further statistical analysis. The main effects of liner ( $p < 0.0001$ ), test-order ( $p < 0.0001$ ), and test-method ( $p = 0.012$ ) were significant. An interactive effect between test order and test method was observed with  $OP_{lp}$  values decreased significantly across time, from the first measurement (15.7 kPa) to the fourth one (11.8 kPa); and a declining trend for  $OP_{np}$  with a significant

difference between first and fourth but no significant differences between the first and second or third and fourth measurements.  $OP_{np}$  measurements were thus less affected by test order than were  $OP_{lp}$  measurements. Interactive terms test-method x liner, test-order x liner and test-method x test-order x liner were not statistically significant and were dropped from the final model.

$OP_{lp}$  values were slightly higher than  $OP_{np}$  values (13.9 kPa vs. 13.4 kPa) as shown in Table 1. This differs from previous results of Mein et al. (2003) and Gomez (2010), in which the  $OP_{lp}$  values were about 30% lower than  $OP_{np}$  measurements for the same liner type. These studies used different populations of cows and the test methods were also somewhat different than the ones used in our study.

Differences in OP resolution: Gomez (2010) measured  $OP_{lp}$  starting with 2 kPa in the pulsation chamber with stepwise increases of 2 kPa. Our method started with 0 kPa in the pulsation chamber and allowed for better resolution of OP measurements (0.1 kPa).

Differences across cows and teats: Teat length and shape influence OP values. Mein et al. (2003) and Gomez (2010) used different groups of cows with different teat lengths and teat diameters that could partially differences in OP values. We tested both methods ( $OP_{lp}$  and  $OP_{np}$ ) on the same group of cow with homogeneous teats, ranging between 40 and 50 mm, during the same field test.

Differences in liner-closed duration: Mein et al. (2003) made  $OP_{np}$  measurements by removing the short pulse tube from one teat cup, and the slowly increasing PCV using a hand pump, until milk flow was observed. This method provided a very long liner-closed, or d-phase, of pulsation (up to 30 s). Our method allowed for a liner-closed period of less than 3 s.

Differences in liner-opening duration: The pulsation-less method used by Mein et al. (2003) to measure  $OP_{np}$  may have resulted in teat end congestion occurring during the slow opening of the liner (also up to 30 s). Teats have been shown to start to congest about 500 ms after the liner is opened (Williams et al., 1981). Gomez (2010) found that the limited pulsation applied while measuring  $OP_{lp}$  was less likely to result in teat end congestion than normal milking. This could explain why the  $OP_{lp}$  values found by Gomez (2010) were lower than the  $OP_{np}$  values reported by Mein et al. (2003).

Our system allowed measuring  $OP_{np}$  in about one third of time (10 s) as required by Mein et al. (2003), while the time measuring  $OP_{lp}$  were comparable with Gomez (2010). This could explain why the difference in our  $OP_{np}$  and  $OP_{lp}$  measurements was smaller (0.5 kPa) than the difference reported previously. With our method, OP measurements were simple, fast and repeatable on the same cow and approximated normal milking conditions. We were also able to switch between the  $OP_{lp}$  method to the  $OP_{np}$  methods seamlessly during the

milking of the same cow providing a more reliable comparison of the two methods.

OP values decreased steadily from the first (15.0 kPa) to the fourth test (12.4 kPa) as shown in Table 2. Similar OP values decreasing over the time were found during an experimental trial performed with the OPB on five round European liners tested in three different dairy farms (F. M. Tangorra, unpublished data). In that study a significantly decrease of about 3 kPa in OP values were recorded, using the  $OP_{lp}$ , at one and three minutes from the beginning of the milking. Additionally, a positive significant correlation was found between teat lengths and OP values measured at one minute after the milking unit attachment, but not at the third minute of milking. These results suggest setting a standard period after the cluster attachment on an individual cow to perform the OP measurements in order to make the average values repeatable and comparable. As a guideline, taking into account that peak milk flow is usually reached after 30 s when cows are properly prepared, and also avoiding potential effects of the teat penetration into the liner on the OP values, measurements should be made at a standard time of 1 minute after teat cup attachment, as previously suggested by Mein et al. (2003).

The OP was significantly higher for round liners than for triangular liners, as found by Gomez (2010). Van der Tol et al. (2010) reported that a triangle liner distributed pressures more evenly over the teat surface with lower maximum pressure on the teat-end than did a round liner. This concentration of pressure at the teat-end could be a possible explanation for the greater OP exhibited by round liners compared to triangular ones.

The very low OP values for liner F (0 kPa) are due to the unique design of this triangular liner. physical inspection as well as measurements taken with the ATS indicate that some compression is applied by this liner when it is fully closed. Zero OP values for this liner emphasize that OP is not a direct measure of LC and may have some limitations for liners or milking conditions that produce with very low LC.

#### *6.4.2 Artificial teat sensor*

LC measurements for three round liners, with ATS insertion depth of 60 mm and across the range of PD tested, are shown in Figure 2. LC increased with increasing PD across the liner for all liners with the LC for the highest compression liner (A) affected more by PD than liners B and C. LC measurements were considerably higher when the ATS sensing surface was facing the flat side of the triangular liners than when the sensing surface was facing the corner of the triangular liners. This was likely because the flat plat in the center of the ATS interfered with the collapse of the triangular liners. The ATS was therefor not considered reliable for measuring LC for triangular liners.

The estimated LC in round liners (A, B, and C) was positively correlated ( $R^2$  ranging from 0.97 to 0.91) with the pressure difference across the liner wall from 30 kPa to 50 kPa. Similar results were found by Davis et al. (2001) and Muthukumarappan et al. (1994), applying air pressure to the pulsation chamber. Although the results of the ATS for triangular liners is not entirely reliable, it does appear as if triangular liners showed less change in LC with pressure difference than did round liners. This could be related to differences in the collapse pattern between triangular and round liners observed by van der Tol et al. (2010).

#### *6.4.3 Overpressure vs. Liner Compression measurements*

The relationship between  $OP_{ip}$ , using data from the test performed one minute after unit attachment, and LC, for a vacuum level of 40 kPa and insertion depth of 60 mm, is shown in Figure 4. For the triangular liners, LC data is presented for both orientations of the sensor as well as the average value. The correlation between OP measurements and estimated LC values was very high with a  $R^2$  of 0.96.

## **6.5 Conclusions**

The  $OP_{ip}$  method showed significantly higher liner Overpressure values than the  $OP_{np}$  method (0,5 kPa) and decreased over the time. This difference was less than that previously reported in the literature. We recommend using the  $OP_{ip}$  method with values recorded 1 min after the milking unit is attached to a well stimulated udder to reduce the variability of the test and approximate normal milking conditions. The use of the Artificial Teat Sensor to estimate Liner Compression in triangular liners needs further investigations due to the particular collapsing characteristics of these liners and the resulting effect on sensor response. The wide range of OP found across the different liner tested (0-18 kPa) represents an important aspect of liner characterization.

#### *6.5.1 Acknowledgements*

The authors thank Milkline S.r.l. (Podenzano, Italy) for building and providing the OP Bucket and for their support and assistance.



## 6.6 References

- Butler, M. C.** 1993. A mathematical model of the force exerted by the teatcup liner on the dairy cow's teat. *J. Agr. Eng. Res.* 54: 211-217.
- Caruolo, E. V.** 1983. Measuring force of massage produced by the teatcup liner. *J. Dairy Sci.* 66: 2441-2445.
- Davis, M. A., D. J. Reinemann, and G. A. Mein.** 2001. Development and Testing of a Device to Measure Compressive Teat Load Applied to a Bovine Teat by the Closed Teatcup Liner. *Pages 1-13 in ASABE Ann. Intl. Mtg. Proc., Sacramento, CA.*
- Gates, R S., and N. R. Scott.** 1986. Measurements of effective teat load during machine milking. *Trans. ASAE.* 29(4): 1124-1130.
- Gomez, S. A.** 2010. MS Dissertation, University of Wisconsin, Madison. The interactive effect of linear characteristics, milking vacuum and pulsation settings on milking performance.
- Mein, G. A., and D. J. Reinemann.** 2009. Biomechanics of Milking: Teat – Liner Interactions. *Paper Number: 09743 in ASABE Ann. Intl. Mtg. Proc., Reno, NV.*
- Mein, G. A., M. D. Williams, and D. J. Reinemann D.J.** 2003. Effects of milking on teat-end hyperkeratosis: 1. Mechanical forces applied by the teatcup liner and responses of the teat. *Pages 114-123 in 42th Natl. Mastitis Council. Ann. Mtg. Proc., Fort Worth, TX. Natl. Mastitis Council. Inc., Madison, WI.*
- Mein, G.A., D.J. Reinemann and PD Thompson.** 2013. Understanding the contribution of Cyclic Liner Compression to Effective Pulsation. *Proceedings of the 2013 Annual Meeting of the National Mastitis Council.*
- Mein, G. A., D. M. Williams, and C. C. Thiel.** 1987. Compressive load applied by the teatcup liner to the bovine teat. *J. Dairy Res.* 54: 327-337.
- Mein, G.A., and D.M. Williams.** 1984. Liner massage and teat condition. *Pages 4-18 in 23th Natl. Mastitis Council. Ann. Mtg. Proc., Kansas City, MO. Natl. Mastitis Council. Inc., Madison, WI.*

**Reinemann, D.J., and G.A. Mein.** 2011. Unraveling the Mysteries of Liner Compression. *Proc. of the 2011 Countdown Meeting, Melbourne Australia.*

**Reinemann, D. J.** 2012. The smart position on teat condition. *Pages 124-131 in New Zealand Milk Quality Conference Proc., Hamilton, NZ.*

**SAS Institute.** 2012. Statistical Analysis System. SAS Inst. Inc., Cary, NC.

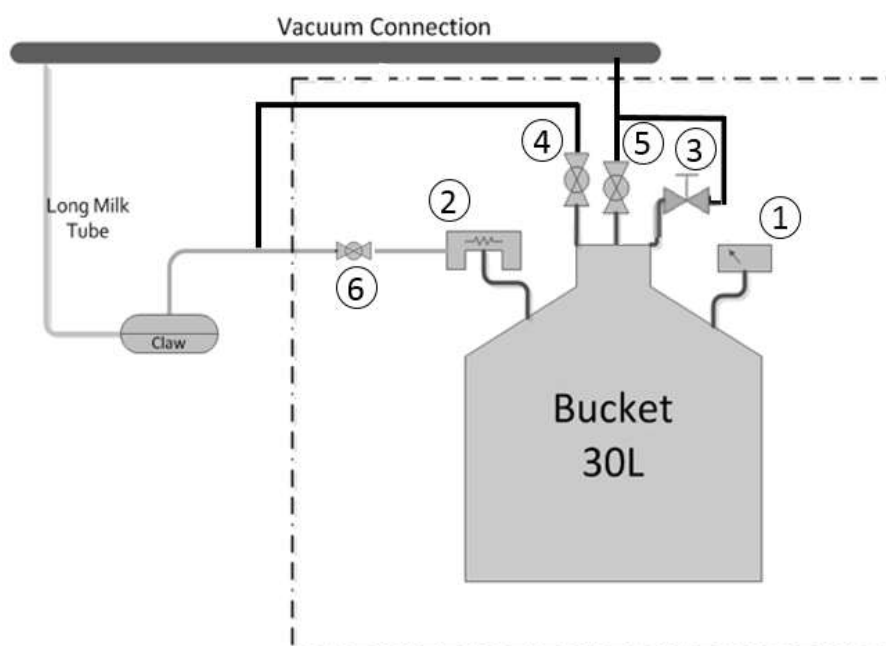
**Thompson, P.D.** 1978. Measurements for studying machine milking. *Pages 176-185 in 17th Natl. Mastitis Counc. Ann. Mtg. Proc., Louisville, KY. Natl. Mastitis Counc. Inc., Madison, WI.*

**Van der Tol P. P. J., W. Schrader, and B. Aernouts.** 2010. Pressure distribution at the teat-liner and teat-calf interfaces. *J. Dairy Sci. 93: 45-52.*

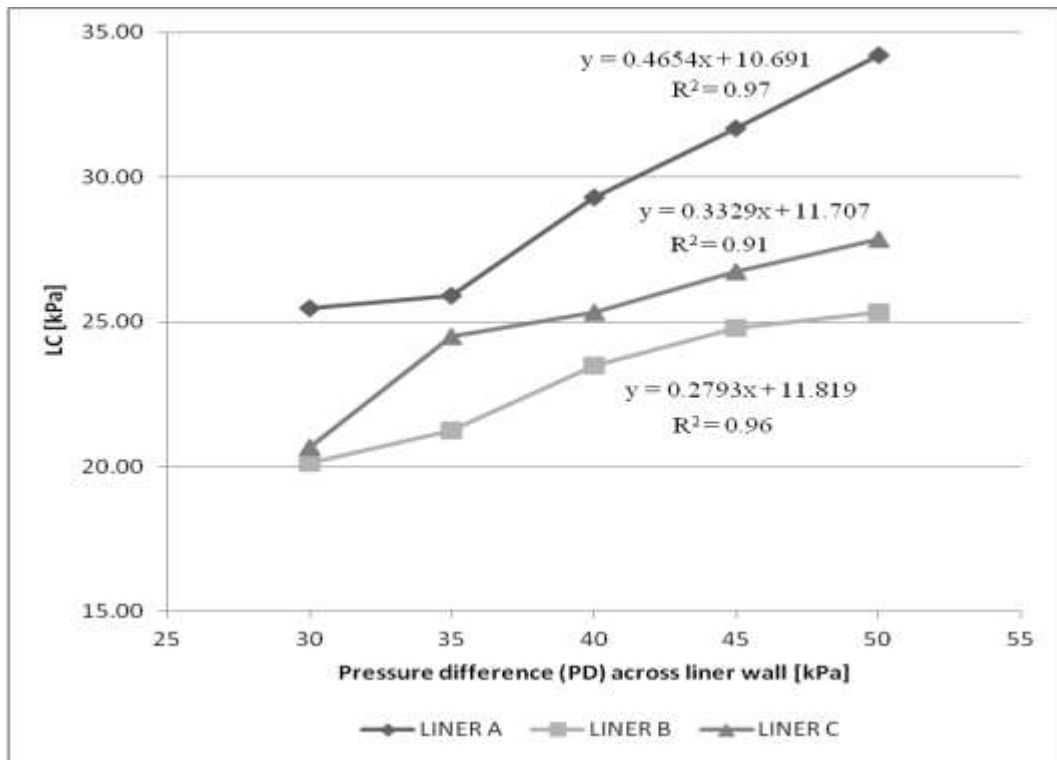
**Williams D.M., G.A. Mein, and M.R. Brown.** 1981. Biological responses of the bovine teat to milking: information from measurements of milk flow-rate within single pulsation cycles. *J. Dairy Res. 48: 7-21.*

**Zucali, M.R.D., D.J. Reinemann, A. Tamburini, and R. Bade.** 2008. Effects of liner compression on teat end hyperkeratosis. *Paper number: 083798 in ASABE Ann. Intl. Mtg. Proc., Providence, RI.*

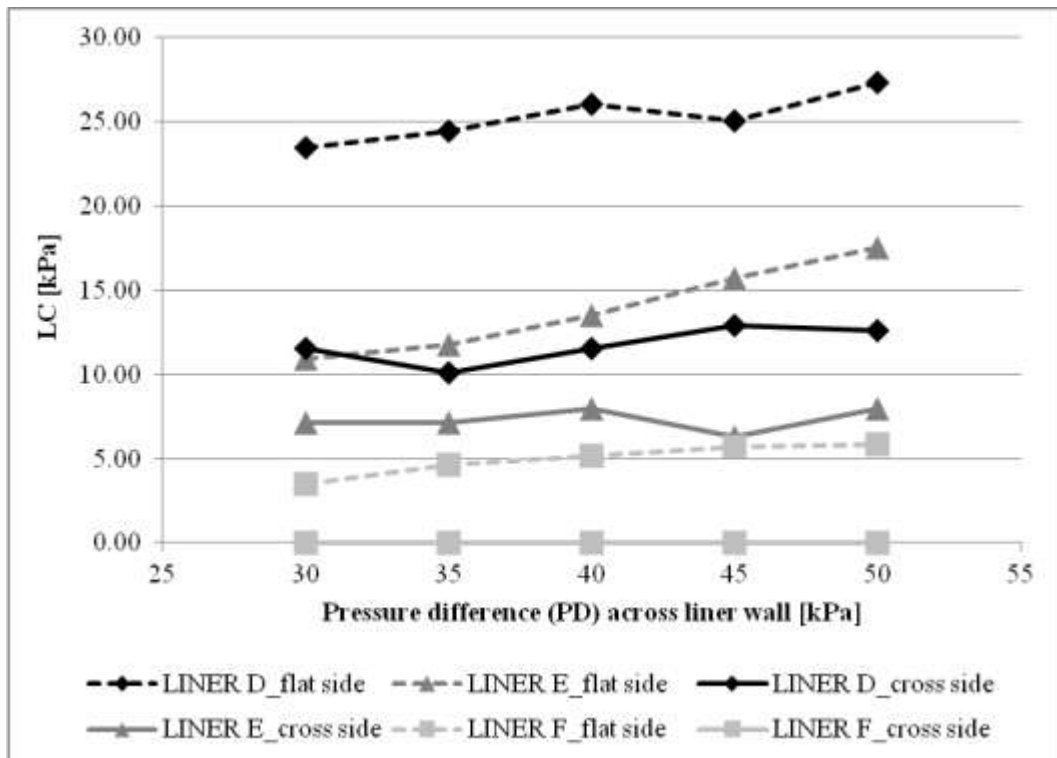
## 6.7 List of figures



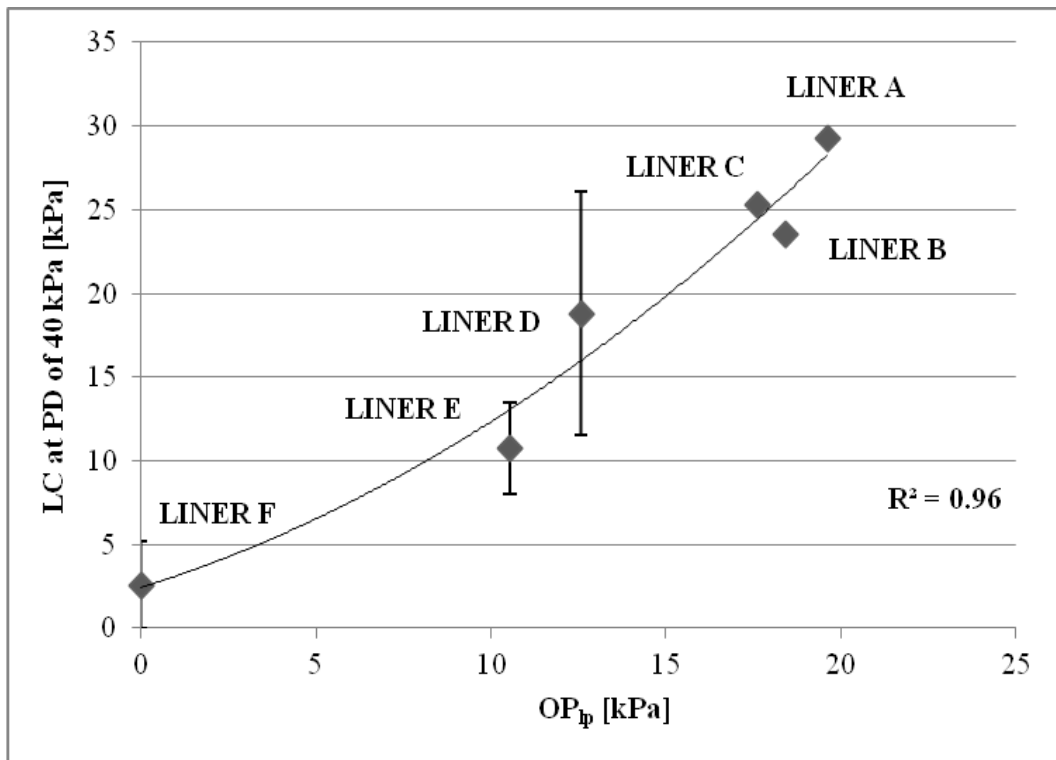
**Figure 1.** Layout of the Overpressure Bucket (OPB) and its connections to the milking machine: 1) digital vacuum sensor; 2) electronic servo-pulse pulsator; 3) needle valve (NV); 4) 5) open/close valves (V1 and V2); 6) small open/close valves (v1 and v2) on long pulse tube.



**Figure 2.** Liner Compression (LC) applied to the Artificial Teat Sensor (insertion depth of 60 mm) for round liners tested applying vacuum of 30 to 50 kPa to the short milk tube.



**Figure 3.** Liner Compression (LC) applied to the Artificial Teat Sensor (insertion depth of 60 mm) by the triangular liners tested applying vacuum of 30 to 50 kPa in the short milk tube and with the Artificial Teat Sensor placed with the load cell facing the flat side and the corner of the liner.



**Figure 4.** Relationship between Overpressure measured with limited pulsation ( $OP_p$ ) and Liner Compression (LC) measured with the Artificial Teat Sensor (applying 40 kPa of vacuum to the short milk tube, and insertion depth of 60 mm) for the six liners tested. Values reported for the triangular liners (D, E, and F) are for the sensor facing the flat side and corner of the liner (max and min values) and the average of these two measurements (diamond).

## 6.8 List of tables

**Table 1.** Overpressure measured using the two different methods ( $OP_{np}$  and  $OP_{lp}$ )

Test Method	Ls Means $\pm$ SEM
$OP_{np}$	$13.43 \pm 1.45^a$
$OP_{lp}$	$13.89 \pm 1.45^b$

<sup>(a,b)</sup> Different letter in the same column denotes significant difference ( $P < 0.05$ ).

**Table 2.** OP values by test order.

Test Order	Ls Means $\pm$ SEM
1	$14.99 \pm 1.46^{A,a}$
2	$14.21 \pm 1.46^{A,b}$
3	$13.09 \pm 1.46^{B,c}$
4	$12.37 \pm 1.46^{B,d}$

<sup>(A,B)</sup> Different letter in the same column denotes significant difference ( $P < 0.001$ ).

<sup>(a,b)</sup> Different letter in the same column denotes significant difference ( $P < 0.05$ ).

<sup>(c,d)</sup> Different letter in the same column denotes significant difference ( $P < 0.05$ ).

**Table 3.** OP six liners (Ls Means $\pm$ SEM)

Liner	Shape	OP
Liner A	Round	$18.2 \pm 1.46^A$
Liner B	Round	$15.6 \pm 1.46^B$
Liner C	Round	$14.2 \pm 1.46^C$
Liner D	Triangular	$10.5 \pm 1.46^D$
Liner E	Triangular	$9.8 \pm 1.46^D$
Liner F	Triangular	0.00*

<sup>(A, B, C, D)</sup> Different letter in the same column denotes significant difference ( $P < 0.001$ ).

\*All values recorded as 0.0, SEM not calculable.





# **CHAPTER 7**

## **General Discussion**



## 7. General discussion

Automation and sensor-based technologies enable dairy farmers to control and manage larger herds, saving time and providing information about the production process, the herd and the individual animal (Precision Dairy Farming - PDF). Information obtained from PDF technologies is only useful if it is correctly interpreted and utilized effectively in decision making. This aspect is the key factor in managing dairy farm through a “proactive” perspective rather than a “reactive” one, however depending on the skills of each farmer.

The objectives of the thesis were: (i) to evaluate the use of different PDF systems in three important areas of dairy farming - chapter 3, 4 and 5; (ii) to assess different methods of estimating liner compression (LC) by using a new test device and a novel artificial teat sensor, both specifically designed and built.

The PDF systems investigated in chapter 3 and 4 showed to be useful support systems for decision making.

More specifically, the proactive herd management system installed for the reproduction control and management investigated in the first study (chapter 3), showed its capacity to assure a single cow better control that led to a high improvement of the average reproductive indexes. The enhancement of the economic performances related only to this aspect were sufficient to guarantee an acceptable five-year return on investment (ROI) value for the economic investment derived from the adoption of this system. These encouraging results would be further improved in the future when the additional management options of this system (LDH analysis for mastitis detection, Urea and RHR for ketosis detection and feeding improvement) will produce their effect on the herd;

The GSM-based remote alarm system for the automatic calving detection, assessed in the second study (chapter 4), proved to be a useful and reliable tool to detect the incoming fetus expulsion allowing the farm staff to be present at the moment of calving. The farm staff, if present during this crucial and important moment, could assist the animal preventing possible problems for the cow and the calf. This possibility could be of great interest particularly with heifers and with problematic cows. Anyway, the device just sends an alarm and excellent results could be obtained only if there is a responsible and ready-to-act farm staff and then good management of the calving barn.

In the fourth study (chapter 5) the response of buffaloes to automatic milking, examining the relationships between milking interval, milk production, and milking time for this species were investigated and results showed that automatic

milking could be a promising alternative to conventional mechanical milking. New options for the management of dairy buffalo farms could be considered.

Overall, the potentialities of the above mentioned systems, could be fully expressed when the heterogeneity of hardware, software, data formats, technologies, and communication protocols that characterize these systems will be overcome by a standardized solution to enable a simple and cohesive interoperability among them through the use of Internet (Internet of Things).

PDF systems dramatically increase the amount of data available for the end user to process. This feature coupled with the Internet's ability to communicate this data, will enable farmers and researchers to advance even further.

The last study (chapter 6) represents the process in developing a precision dairy farming tool: from the development of a device that enables to collect data, to the processing of these data that are transformed in useful information. The aim of this study was to assess different methods of estimating liner compression (LC) by using a new test device and a novel artificial teat sensor, both specifically designed and built. Results of this study allowed to recommend a method for measuring liner compression and how to perform the tests in the field to obtain useful and reliable information.

# CHAPTER 8

## Summary



## 8. Summary

The objectives of the thesis were: (i) to evaluate the use of automatic systems and the related sensor-based technologies (Precision Dairy Farming – PDF – systems) in three important areas of dairy farming; (ii) to assess different methods of estimating liner compression (LC) by using a new test device and a novel artificial teat sensor, both specifically designed and built. Four studies were carried out to achieve these goals.

In the first study *“Use of a proactive herd management system in a dairy farm of northern Italy: technical and economic results”* the reproductive and economical performances of an AMS farm that adopted a proactive herd management system (Herd Navigator™) were analyzed. Reproductive and economic data were recorded before and one year after the installation of Herd Navigator™. Number of days open reduced from 166 to 103 days, number of days between the first and second insemination decreased from 45 to 28 days, and days for identifying an abortion were 80 % less, from 31 to 6 days. The preliminary results highlighted the usefulness of the proactive herd management system implemented for the reproduction management. A basic economic model was proposed to evaluate the potential economic benefits coming from the introduction of this technology. The model considered the benefits deriving from the reduction of reproduction problems and, consequently, of days open. Considering the effects related to the above mentioned aspects in a case study involving 60 dairy cows, a return on investment over 5 years was calculated.

In the second study *“Evaluation of an electronic system for automatic calving detection on a dairy farm”*, a GSM-based remote alarm system for automatic calving detection was evaluated - in terms of sensitivity and PPV- as useful and reliable tool to detect the exact moment of calving in the field. Up to date, various monitoring technologies and protocols have been proposed to predict the exact moment of the calving but none of them have been adopted widely by producers due to high costs, difficulties of execution or lack of quality staff. Visual observation of the cow’s behavior is still the most frequent. The system object of the study, showed very high sensitivity and PPV, respectively 100% and 95 %, allowing the farm staff to be present at the moment of calving in 100 % of cases when cow were monitored using this system. Cows not monitored by this system, were assisted only in 17% of cases ( $P<0.001$ ). The farm staff, if present during this crucial and important moment, could assist the animal preventing possible problems for the cow and the calf. This possibility would be of great interest particularly with heifers and with problematic cows.

In the third study *“Evaluation of the performance of the first automatic milking system for buffaloes”*, the response of buffaloes to automatic milking and the related

performance of the system were investigated. Automatic milking systems (AMS) are a revolutionary innovation in dairy cow farming and can now be considered a well-established technology. In 2008, automatic milking of dairy buffaloes was introduced for the first time in a commercial farm in southern Italy. The aim of this study was to evaluate the response of buffaloes to automatic milking, examining the relationships between milking interval, milk production, and milking time for this species. A total of 7,550 milking records from an average of 40 buffaloes milked by an AMS were analyzed during a 3-mo experimental period at a commercial farm with Italian Mediterranean buffaloes in southern Italy. Date and time of animal identification, milk yield, milking duration, milking interval, and average milk flow rate were determined for each milking. The results were also used to predict the maximum number of milkings per day and the optimal number of buffaloes per AMS for different levels of milk production. The average interval period between 2 consecutive milkings was 10.3 h [standard deviation (SD) 3.3]. Overall, 3.4 and 25.7% of the milkings had an interval of  $\leq 6$  h or  $>12$  h, respectively. Milking duration averaged 8.3 min per buffalo per milking (SD 2.7). The average milk flow rate was 1.3 kg/min (SD 0.5) at a milk yield of 2.8 kg per milking (SD 1.4). Assuming that the milking station is occupied 80% of the time, the number of milkings ranged from 136 to 152 per day and the optimal number of buffaloes per AMS ranged from 59 to 66 when the production level increased from 2 to 5 kg of milk per milking. Automatic milking systems seems suitable for buffalo, opening new options for the management of dairy buffalo farms.

In the last study "*Methods of estimating Liner Compression*" the aim was to compare different methods of estimating liner compression (LC) by using a new test device and a novel artificial teat sensor, both specifically designed and built. Liner compression (LC) is the pressure applied to the teat end when liner collapses during the d-phase of pulsation. Liners with higher LC are thought to increase the occurrence of teat-end hyperkeratosis. Overpressure (OP) has been proposed as a relative indicator of LC. By using the new test device developed, two methods of measuring overpressure were compared: liner overpressure (OP) was measured with no pulsation ( $OP_{np}$ ) and with limited pulsation ( $OP_{lp}$ ) repeatedly on the same cow during a single milking. Each of the six liners (three round liners and three triangular liners) used in this study were tested on the same six experimental cows.  $OP_{np}$  and  $OP_{lp}$  were measured on all four teats of each experimental cow twice for each liner. The order of  $OP_{np}$  and  $OP_{lp}$  alternated sequentially for each cow test. The OP results for the six liners were also compared to LC estimated on the same liners with a novel artificial teat sensor (ATS). The  $OP_{lp}$  method showed small but significantly higher values than the  $OP_{np}$  method (13.9 kPa vs. 13.4 kPa). The  $OP_{lp}$  method would be recommended as the preferred method as it more closely approximates normal



milking condition. OP values decreased significantly between the first and the following measurements, (from 15.0 kPa to 12.4 kPa). Thus, performing the OP test at a consistent time, one minute after attaching the teatcup to a well-stimulated teat, to reduce the variability produced by OP changing during the peak flow period would be recommend. The new test device showed several advantages over previously published methods of measuring OP. A high correlation between OP and LC estimated by the ATS was found, however, difficulties were noted when using the ATS with triangular liners.



## **CHAPTER 9**

# **Acknowledgements**



## 9. Acknowledgements

I would like to infinitely thank Dr. Francesco Maria Tangorra, my advisor and great person I could always count on during all these years. You shared your knowledge, taught me a lot but also supported my ideas and stimulated my desire of learning. Your valuable advice was fundamental for my professional and personal growth. Thanks for the big trust that you placed in me.

Many thanks to Professor Massimo Lazzari and Professor Antoniotto Guidobono Cavalchini, your practical way of thinking helped me to overcome the gap between the theory and the real world, providing me the tools not to lose the goal.

A big thank to Gabriele Marchesi and Marco Cattaneo for the opportunity to work together and for the stimulating exchange of views, very important moments of growth for me.

A huge thank to the Professor Douglas J. Reinemann for the big opportunity to work together during my abroad period at the University of Wisconsin-Madison. I spent six intensive and significant months working hard and learning so much! Your way of working and thinking stimulated even more my passion for this work, opened my mind to new potentials and improved my skills to an upper level. It was an amazing experience that made me grow very much.

A special and deep thank to John Penry, fellow adventure, friend and confidant during the six months spent at the University of Wisconsin-Madison. I really miss that time.

A loving and sincere thank to my family and all my friends, who always trust in me. Thanks to support me but most of all to bear me!

A deep and loving thank to Fabio. Our exchange of views is fundamental for me.