



**UNIVERSITÀ DEGLI STUDI
DI MILANO**

**FACOLTÀ DI SCIENZE MATEMATICHE, FISICHE E
NATURALI
DIPARTIMENTO DI CHIMICA ORGANICA E INDUSTRIALE**

**CORSO DI DOTTORATO DI RICERCA IN
CHIMICA INDUSTRIALE-XXIII CICLO**

Chim/06

*Design and synthesis of α -amino acid and
morpholino 'chimera' building-blocks*

FRANCESCA M. FOSCHI

MATR. R07809

TUTOR: Prof. Dario Landini

Co-TUTOR: Dr. Michele Penso

ANNO ACCADEMICO 2009/2010

1-INTRODUCTION.....	3
1.1- PEPTIDOMIMETICS.....	4
1.2- NUCLEOTIDOMIMETICS.....	5
2. α,α-Disubstituted Amino Acids.....	7
2.1- Self-regeneration of stereocentres.....	8
2.2- Diastereoselective alkylation.....	15
2.3- Chiral 2H-azirines and aziridines as building blocks.....	19
2.4 Addition of nucleophiles to imines.....	20
2.5 Addition of nucleophiles to sulfinimines.....	22
2.6 Diastereoselective SN2' substitution.....	23
2.7 Chiron approach.....	24
2.8 Enantioselective synthesis: Alkylation under phase-transfer conditions.....	25
2.9 Transition metal-catalysed allylic alkylation.....	29
3- Memory of chirality.....	35
4- Synthesis of α-quaternaryprolines.....	45
5- Results.....	53
5.1.....	55
5.2.....	65
5.3.....	74
6- Nucleic Acid analogues.....	79
6.1- Native Nucleic Acids.....	63
6.2 Nucleic Acid analogues: Locked Nucleic Acids (LNA).....	87
6.3 Nucleic Acid analogues: Peptide Nucleic Acids (PNA).....	94
6.4 Morpholinos.....	95
7-Results.....	101
7.1-Introduction.....	102
7.2 MORPHOLINOs.....	109
8- SPERIMENTAL SECTION.....	116

1- INTRODUCTION

The design and synthesis of new poly-functionalized molecules, having various functions which cannot be obtained by using natural products, have attracted much attention in organic, bioorganic and medicinal chemistry.

In this wide spreading field of interest, the creation of original 'foldamers'¹ is one of the most important research area for bio-chemists in our century.

The term 'foldamer' is used to describe an artificial oligomer, inspired by biopolymers, with a strong tendency to adopts a specific compact conformation stabilized by non-covalent interactions between nonadjacent monomer units. Foldalmers are molecules that mimic the ability of proteins, nucleic acids, and polysaccharides (the three major biopolymer backbones) to fold into conformationally ordered state in solution, such as secondary structure.

Foldamers have been demonstrated to display a number of interesting supramolecular properties including molecular self-assembly, molecular recognition, and host-guest chemistry. They are studied as models of biological molecules and have been shown to display antimicrobial activity. They have also a great potential application to the development of new functional materials.

There are two major classes of foldamers:

-single-stranded foldamers: peptidomimetics and their abiotic analogues. These kind of compounds can only fold;

-multiple- stranded foldamers: nucleotidomimetics and their abiotic analogues. They can both associate and fold

1.1- PEPTIDOMIMETICS

A peptidomimetic is a small protein-like chain designed to mimic a peptide arising either from modification of an existing peptide, or by designing similar systems which mimic peptides. Therefore, peptidomimetics have general main features analogous to polypeptides and, they have been developed with the purpose of replacing peptide substrates of enzymes or peptide ligands of protein receptors.² The altered chemical

¹ a) Gellman, S.; H., *Acc. Chem. Res.*, **1998**, *31*, 173-180; b) Hill, D. J.; Mio, M. J.; Prince, R. B.; Hughes, T. S.; Moore, J. S. *Chem. Rev.* **2001**, *101*, 3893- 4011; c) Appella, D. H.; Christianson, L. A.; Karle, I. L.; Powell, D. R.; Gellman, S. H. *J. Am. Chem.Soc.* **1996**, *118*, 13071-13072; d) Moore, J. S. *Curr. Opin. Colloid Interface Sci.* **1999**, *4*, 108-116.

² a) Hirschmann, R. *Angew. Chem., Int. Ed.* **1991**, *30*, 1278-1301;b) Giannis, A.; Kolter, T. *Angew. Chem., Int. Ed.* **1993**, *32*, 1244-1267; c) Gante, J. *Angew. Chem., Int. Ed.* **1994**, *33*, 1699-1720; d) Hruby, V. J.; Li, G.; Haskell-Luevano, C.; Shenderovich, M.

structure is designed to improve peptides molecular properties (stability or biological activity). These modifications involve changes to the peptide, that will not occur naturally, through: a) modification of amino acid side chains, (with the incorporation of non-natural amino acids); b) the introduction of constraints to fix the location of different parts of the molecule;³ c) the development of templates that induce or stabilize secondary structures of short chains;⁴ d) the creation of scaffolds that direct side-chain elements to specific locations; e) the modification of the peptide backbone. The family of peptidomimetic can be branched depending on their general chemical characteristics.

1.2- NUCLEOTIDOMIMETICS

The oligonucleotide analogs have immense therapeutic potential because they are used for the regulation of gene expression by silencing the message of the target *mRNA* either by inhibition, alteration in splicing, translational arrest, redirection of polyadenylation, or degradation of the *mRNA* by ribonuclease H.

In the last 25 years, synthetic oligonucleotides have been used in gene therapy, especially in gene activation and repression strategy. However, their potential application has been limited by several factors, principally the susceptibility to nuclease digestion. Moreover, even if the synthetic oligonucleotides can reach the cell nucleus without digestion, not always it can form stable interactions with native nucleic acids to act as therapeutic agent.

With the aim of solve the problem, many nucleic acid analogues were developed in the last few years.

The major modifications are realized at level of the sugar-phosphate backbone, and the first designed analogues with modified backbone, which were devised by Summerton⁵ in 1985, are Morpholino nucleotides, whom riboside moiety is converted into a morpholine ring.

Biopolymers **1997**, *43*, 219-266; e) Hanessian, S.; McNaughton-Smith, G.; Lombart, H. G.; Lubell, W. D. *Tetrahedron* **1997**, *53*, 12789-12854.

3 Rizo, J.; Gierasch, L. M. *Annu. Rev. Biochem.* **1992**, *61*, 387- 418.

4 a) Schneider, J. P.; Kelly, J. W. *Chem. Rev.* **1995**, *95*, 2169-2187; b) Nowick, J. S.; Smith, E. M.; Pairish, M. *Chem. Soc. Rev.* **1996**, *25*, 401-415.

5 Summerton, J.; Weller, D. *Antisense Nucleic Acid Drug Dev.* **1997**, *7*, 187-95.

Few years later, in 1991, Nielsen and co-workers⁶ described Peptide Nucleic Acids (PNA) a oligonucleotide analogue class where the backbone is based on amino acid chain. In 1998 Sing *et al.*⁷ and Obika *et al.*,⁸ independently, reported a minimal alteration of the pentose sugar of ribo- and deoxyribonucleotides that constrained, or “locked,” the sugar in the N-type conformation seen in A-form DNA. This new class of oligonucleotide analogue is called LNA (Locked Nucleic Acids)

6 Nielsen, P.; Egholm, M.; Berg, R.; Buchardt, O. *Science*. 1991, 254, 1497-1500

7 Singh, S. K.; Koshkin, A. A.; Wengel, J.; Nielsen, P. *Chem. Commun.* 1998, 455-456.

8 Obika, S.; Nanbu, D.; Hari, Y.; Andoh, J.; Morio, K.; Doi, T.; Imanishi, T. *Tetrahedron Letters*. 1998, 39, 5401-5404.

2. α,α -Disubstituted Amino Acids

Oligopeptides composed of natural *L*- α -amino acids often form unordered or unstable secondary structures, particularly in the case of short peptides because of the flexibility of natural amino acids.

Thus, the incorporation of rigid amino acid surrogates with conformational constraints into peptides with biological activity, is a very useful tool for the construction of new molecules with improved properties, which may provide information on their bioactive conformation and result in beneficial physiological effects.⁹

To restrict the conformational freedom of amino acids and their peptides, many designs and modifications have been developed so far. Among these conformational restrictions, the replacement of the α -hydrogen atom of *L*- α -amino acids with a substituent, which results in α,α -disubstituted amino acid, has proved to be one of the most interesting and promising strategies and, for this reason, it is very important their synthesis in enantiomerically pure form.

The replacement of the α -hydrogen atom changes the properties of amino acids as follows:

- 1) increase of chemical stability;
- 2) increase of hydrophobicity;
- 3) restriction of conformational freedom of the side chains in amino acids;
- 4) restriction of conformational freedom of their peptides;
- 5) metabolic stability of their peptides.

In the last few decades a variety of α -alkyl α -amino acids have been synthesized.¹⁰ Here we report the most employ techniques to obtain α,α -disubstituted amino acids.

2.1- Self-regeneration of stereocentres

⁹ a) Giannis, A.; Kolter, T. *Angew. Chem., Int. Ed.* **1993**, 32, 1244–1267; b) Gante, J. *Angew. Chem., Int. Ed.* **1994**, 33, 1699–1720; c) McDowell, R. S.; Artis, D. R. *Annu. Rep. Med. Chem.* **1995**, 30, 265–274; d) Hruby, V. J.; Li, G.; Haskell-Luevano, C.; Shenderovich, M. *Biopolymers* **1997**, 43, 219–266; e) Kaul, R.; Balaram, P. *Bioorg. Med. Chem.* **1999**, 7, 105–117; f) Hruby, V. J.; Balse, P. M. *Curr. Med. Chem.* **2000**, 7, 945–970; g) Hruby, V. J. *Acc. Chem. Res.* **2001**, 34, 389–397; h) Venkatraman, J.; Shankaramma, S. C.; Balaram, P. *Chem. Rev.* **2001**, 101, 3131–3152; i) Toniolo, C.; Crisma, M.; Formaggio, F.; Peggion, C. *Biopolymers* **2001**, 60, 396–419; l) Cowell, S. M.; Lee, Y. S.; Cain, J. P.; Hruby, V. J. *Curr. Med. Chem.* **2004**, 11, 2785–2798; m) Sagan, S.; Karoyan, P.; Lequin, O.; Chassaing, G.; Lavielle, S. *Curr. Med. Chem.* **2004**, 11, 2799–2822.

¹⁰ a) Ikunaka M. *Org. Proc. Res. & Dev.* **2007**, 11, 495–502; b) Cativiela, C.; DiazdeVillegas, M. D. *Tetrahedron Asymmetry* **2007**, 18, 569–623; c) Cirilli, M.; Coiro, V. M.; Di Nola, A.; Mazza, F. *Biopolymers* **1998**, 46, 239–244; d) Tanaka, M.; Imawaka, N.; Kurihara, M.; Suemune, H. *Helv. Chim. Acta* **1999**, 82, 494–510; e) Kotha, S. *Acc. Chem. Res.* **2003**, 36, 342–351; f) Pavone, V.; Lombardi, A.; Saviano, M.; Nastri, F.; Zaccaro, L.; Maglio, O.; Pedone, C.; Omote, Y.; Yamanaka, Y.; Yamada, T. *J. Pept. Sci.* **1998**, 4, 21–32.

The principle of 'self-regeneration of stereocentres' (SRS)¹¹ is used to introduce diastereoselectively a new ligand at the original stereogenic centre. It is applied to the synthesis of various acyclic quaternary amino acids. α -Amino acids are usually converted into chiral heterocyclic intermediates from which chiral heterocyclic enolates with diastereotopic faces are generated and then diastereoselectively alkylated.

In this context, oxazolidinones are common intermediates of this approach: alkylation of cis-oxazolidinone **1**, obtained from *N*-benzyloxycarbonyl- L-alanine, takes place opposite to the phenyl ring.¹²

Compound **2** is obtained in good yield after generation of the enolate in the presence of an alkylating agent; its hydrolysis gave the corresponding amino acid **3** (Scheme 1).

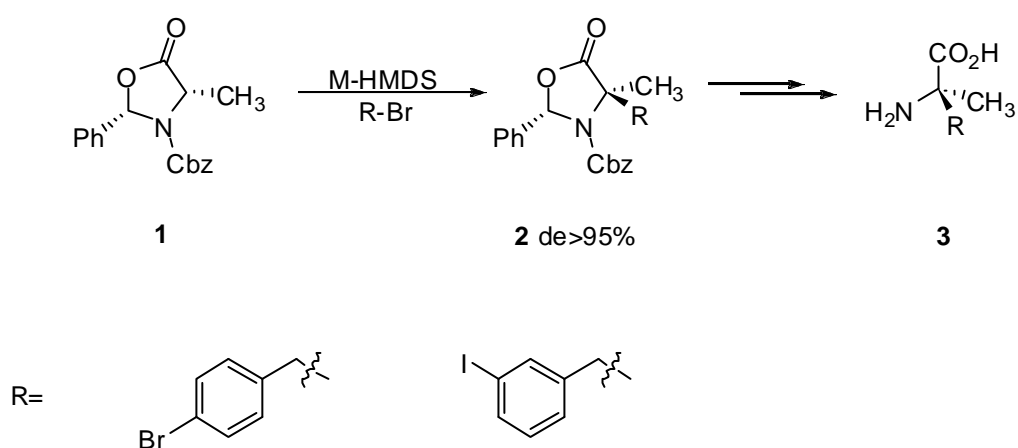

Scheme 1

Alkylated compounds have been transformed into BIRT- 377, that could play an important role as an anti-inflammatory, and (2*S*,3*S*,4*S*)-2-methyl-2-(carboxycyclopropyl) glycine (MCCG), a potent group II metabotropic glutamate receptor antagonist (Figure 1).

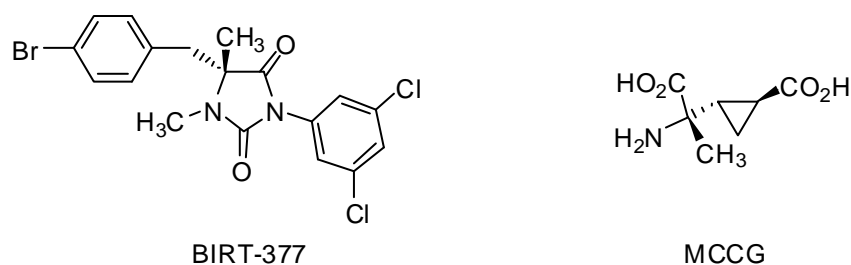
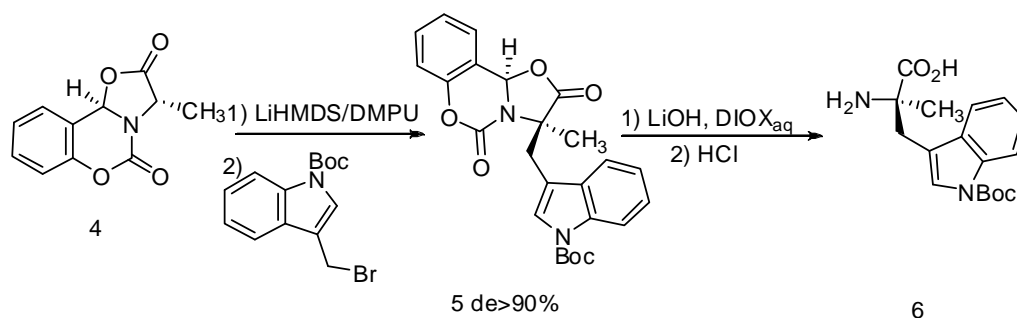

Figure 1

¹¹ Coe, D. M.; Perciaccante, R.; Procopiou, P. A. *Org. Biomol. Chem.* **2003**, *1*, 1106–1111.

¹² Goodman, M.; Zhang, J.; Gantzel, P.; Benedetti, E. *Tetrahedron Lett.* **1998**, *39*, 9589–9592.

Condensation of L-alanine with salicylaldehyde, gave tricyclic trans-oxazolidinone **4**, which was used as an intermediate in the synthesis of orthogonally protected (R)- α -methyltryptophan **6** (Scheme 2).¹³



Scheme 2

Trans-oxazolidinone **7**, derived from L-phenylalanine, proved to be a convenient synthetic precursor in the synthesis of (R)- α -allylphenylalanine **8**, from which a 1,2,3,6-tetrahydropyridine-based phenylalanine mimetic was obtained by combining the SRS principle and ringclosing metathesis (Scheme 3).¹⁴

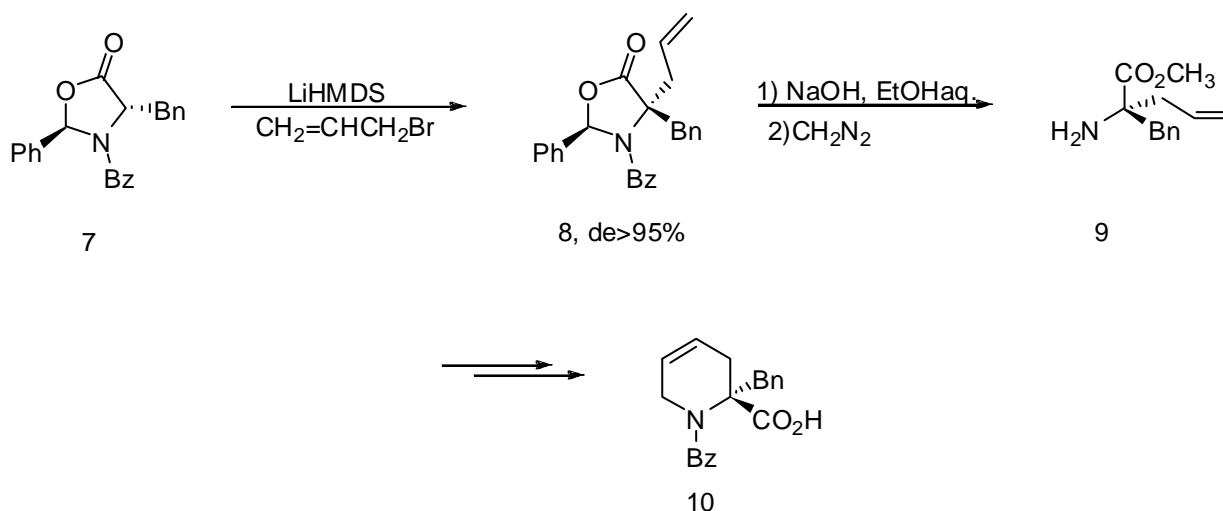

Scheme 3

Likely oxazolidinones, Lithium enolates derived from imidazolidinones are extremely useful intermediates in the synthesis of α -alkyl α -amino acids: cis-imidazolidinones **11**, have been converted into the corresponding α -methyl amino acids.¹⁵ In both cases

¹³ Ma, D.; Zhu, W. *J. Org. Chem.* **2001**, *66*, 348–350.

¹⁴ Abell, A. D.; Gardiner, J.; Phillips, A. J.; Robinson, W. T. *Tetrahedron Lett.* **1998**, *39*, 9563–9566.

¹⁵ Mzengeza, S.; Venkatachalam, T. K.; Diksic, M. *Amino Acids* **2000**, *18*, 81–88.

diastereoselectivity in the electrophilic attack was total and subsequent hydrolysis under the appropriate conditions led to the amino acid in enantiomerically pure form. (Scheme 4).

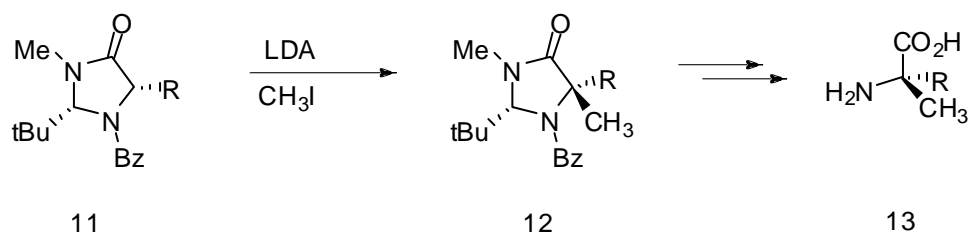

R= Bn, N-Boc-3-indylmethyl
Scheme 4

This methodology has been applied to the synthesis of (S)-2-amino-4-fluoro-2-methyl-4-pentenoic acid.¹⁶ Alkylation of imidazolidinone **14** with allyltosylate led to exclusive formation of compound **15**, which upon acidic hydrolysis followed by basic hydrolysis provided the desired amino acid **16** (Scheme 5)

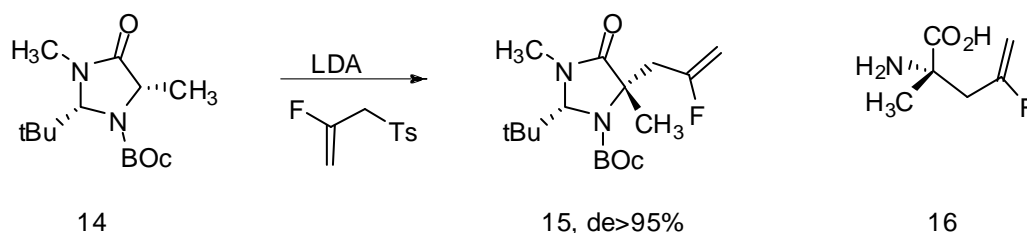

Scheme 5

L-Asparagine was the starting material in the synthesis of cis-tetrahydropyrimidinones **17**, a new class of heterocyclic systems from which α,α -dialkyl amino acids can be obtained through the SRS strategy.¹⁷ (Scheme 6)

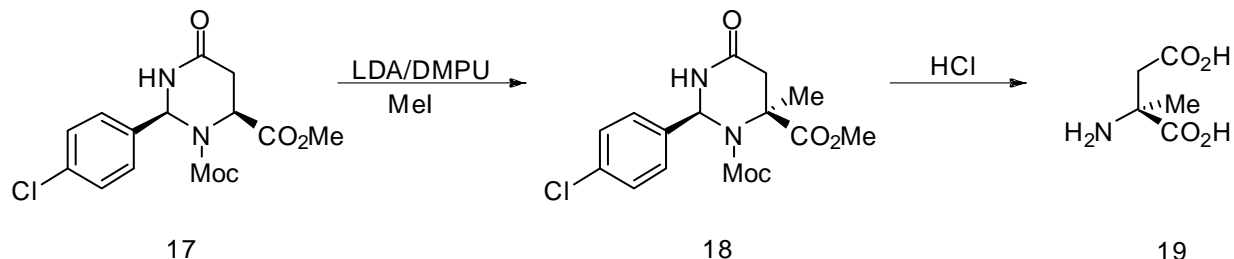

Scheme 6

¹⁶ Shendage, D. M.; Fröhlich, R.; Bergander, K.; Haufe, G. *Eur. J. Org. Chem.* **2005**, 719–727.

¹⁷ Hopkins, S. A.; Ritsema, T. A.; Konopelski, J. P. *J. Org. Chem.* **1999**, *64*, 7885–7889.

The C2 aromatic substituent directs the alkylation process and the electrophile enters in a trans disposition. The main problem in the alkylation step is the choice of both a suitable base and the reaction conditions to achieve monoalkylation. The use of LDA and an excess of lithium chloride in the presence of DMPU gave monoalkylated compound **18** as a single diastereoisomer in high yield; subsequent hydrolysis led to (S)- α -methylaspartic acid in enantiomerically pure form (Scheme 6).

Cis-Tetrahydropyrimidinone **20** (obtained from L-asparagine, isobutyraldehyde and benzoyl chloride) has been converted into the corresponding iminoester **21**, which is a convenient intermediate for the synthesis of α -methylaspartic acid derivatives.¹⁸ Lithium enolates were generated by treatment of the heterocycle with LDA and quenched with various electrophiles to afford trans alkylated compounds with complete diastereoselectivity. Hydrolysis in acidic give the free α -alkyl amino acids. Partial hydrolysis can be performed under relatively mild conditions to afford α -alkyl aspartic acid

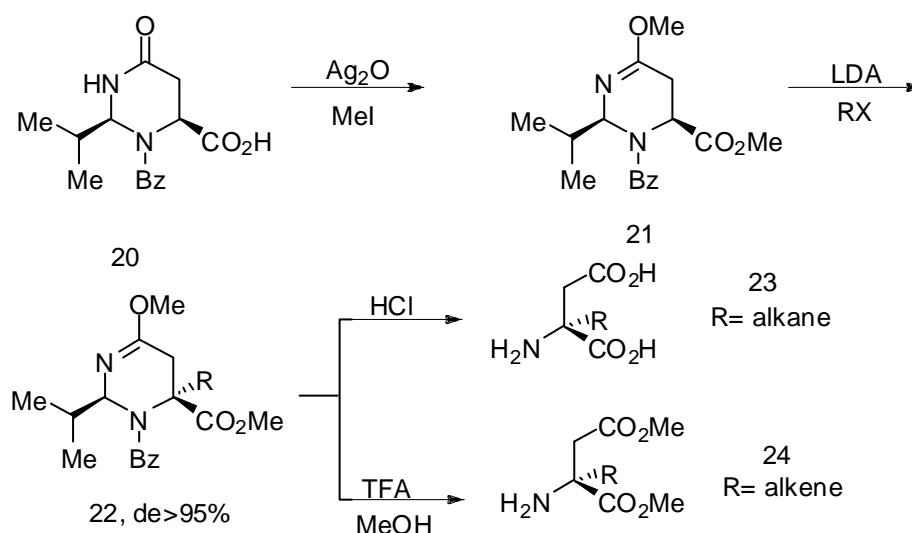

derivatives with preservation of the alkene moiety (Scheme 7).

Scheme 7

Cis- and trans-oxazolidines obtained from serine, have been used as substrates in alkylation reactions (Scheme 8).¹⁹ The alkylation took place with a total diastereoselectivity opposite to the *tert*-butyl group, although 2 equiv of base were

¹⁸ a) Juaristi, E.; Lopez-Ruiz, H.; Madrigal, D.; Ramirez-Quiros, Y.; Escalante, J. *J. Org. Chem.* **1998**, *63*, 4706–4710; b) Juaristi, E.; Balderas, M. Lopez-Ruiz, H.; Jimenez-Perez, V. M.; Kaiser-Carril, M. L.; Ramirez-Quiros, Y. *Tetrahedron: Asymmetry* **1999**, *10*, 3493–3505.

¹⁹ a) Brunner, M.; Saarenketo, P.; Straub, T.; Rissanen, K.; Koskinen, A. M. P. *Eur. J. Org. Chem.* **2004**, 3879–3883; b) Di Giacomo, M.; Vinci, V.; Colombo, L. *Tetrahedron: Asymmetry*, **2008**, *19*, 247–257.

necessary to obtain useful yields. Alkylated compounds derived from the reaction of cis-oxazolidine were obtained with higher yields and lower diastereoselectivities than those derived from the reaction of trans-oxazolidine.

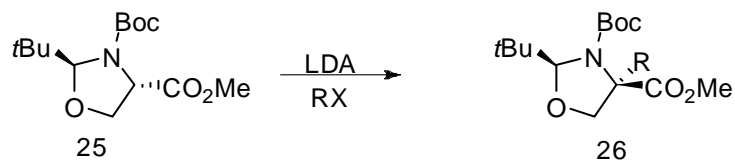

Scheme 8

N-benzoyl-L-vinylglycine methyl ester **27** was converted into a mixture of cis- and trans-oxazolines (**28**, **29**) that, after isolation, serve as synthetic precursors for α -substituted vinyl amino acids.²⁰ Each oxazoline reacted with alkyl halides to afford the corresponding α -alkylated compound, in which the electrophile entered opposite to the phenylselenomethyl group with total diastereoselectivity. The α -vinyl moiety **32** was recovered in three steps: basic hydrolysis of the oxazoline, stereoselective substitution of the phenylselenenyl group by a tributylstannyl group (compound **31**) and final destannylation in acidic environment. In addition, the α -tributylstannylvinyl group proved to be extremely versatile for obtaining α,α -dialkyl amino acids **33** through Stille coupling or conversion to a diene moiety followed by a Diels–Alder reaction (Scheme 9).

²⁰ a) Berkowitz, D. B.; McFadden, J. M.; Chisova, E.; Semerad, C. L. *J. Am. Chem. Soc.* **2000**, *122*, 11031–11032; b) Berkowitz, D. B.; Chisova, E.; McFadden, J. M. *Tetrahedron* **2001**, *57*, 6329–6343.

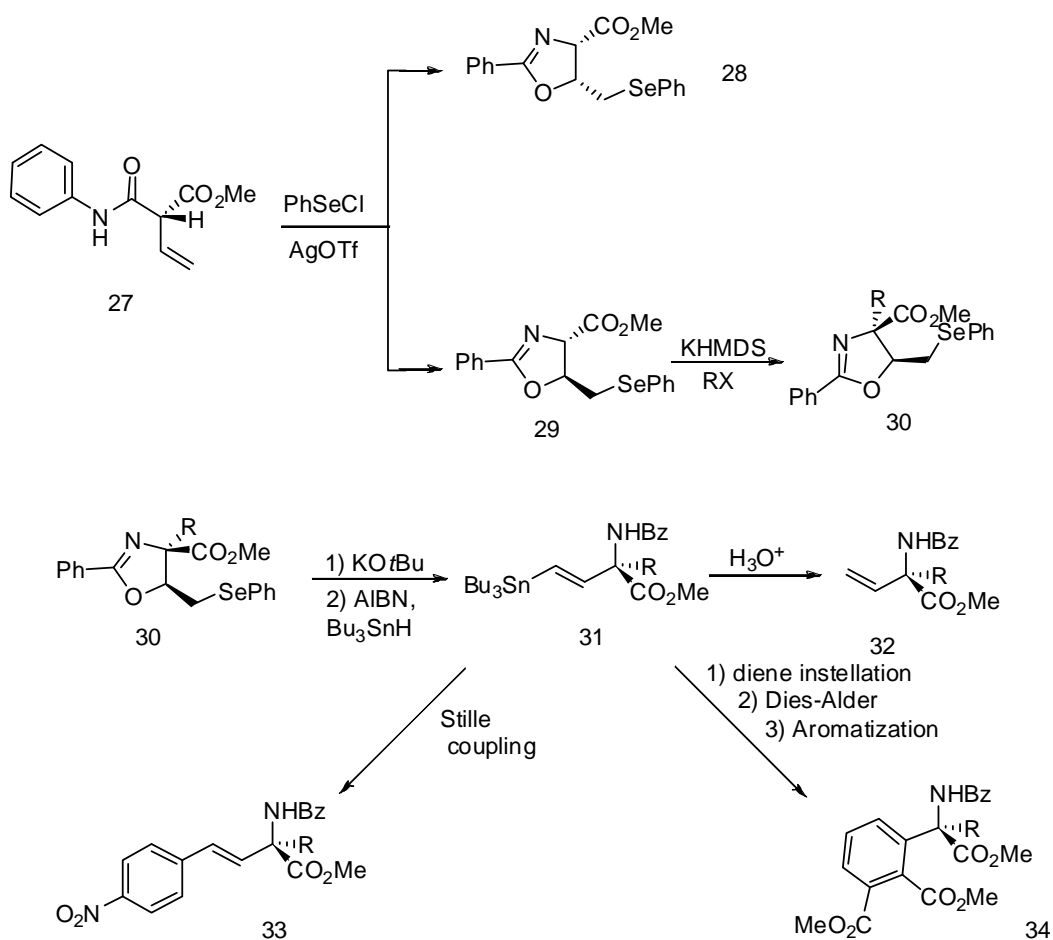

Scheme 9

Tryptophan can be diastereoselectively α -alkylated using a tetrahydropyrroloindole as a chiral intermediate in an SRS process.²¹ The synthesis of **36** was performed by cyclization of conveniently protected (*R*)-tryptophan and subsequent *N*-benzyloxycarbonylation of the indoline nitrogen. Alkylation at the α carbon of compound **35** gave a good yield and complete diastereoselectivity at room temperature, using LiHMDS as the base and DMPU as a cosolvent. Alkylated tetrahydropyrroloindoles were easily converted to the corresponding *N*-benzyloxycarbonyl α,α -dialkyl amino acids **38** by treatment first with trifluoroacetic or sulfuric acid to recover the indole ring and then with tetrakis(triphenylphosphine) palladium(0) to remove the allyl protecting group from the carboxylic acid moiety (Scheme 10).

²¹ Ashwood, V. A.; Field, M. J.; Horwell, D. C.; Julien-Larose, C.; Lewthwaite, R. A.; McCleary, S.; Pritchard, M. C.; Raphy, J.; Singh, L. *J. Med. Chem.* 2001, 44, 2276–2285.

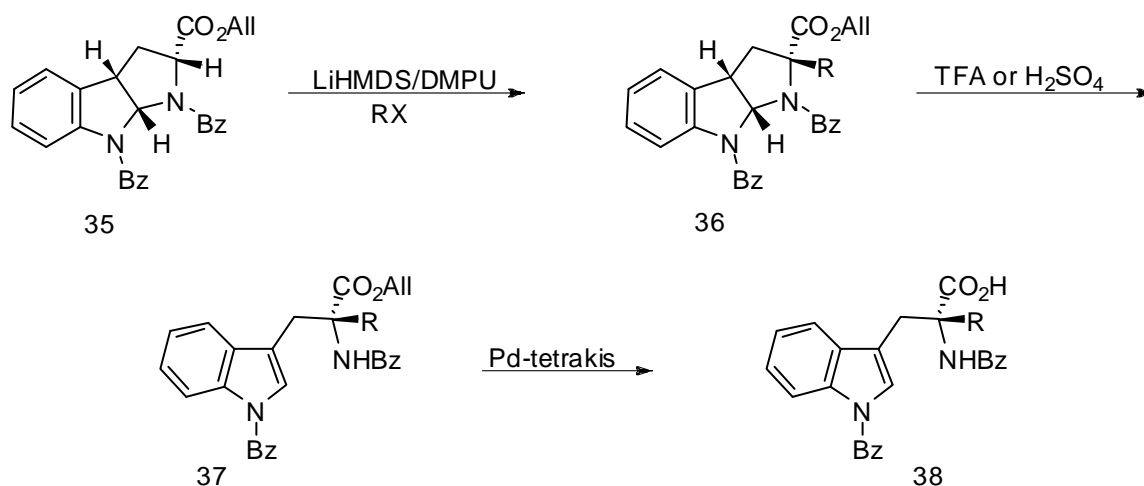

Scheme 10

2.2- Diastereoselective alkylation

Diastereoselective syntheses involve the use of appropriate synthetic equivalents incorporating a covalently bonded chiral auxiliary.

Imines derived from α -amino acids and aldehydes are reactive substrates for alkylation and the use of chiral aldehydes enables this reaction to be performed diastereoselectively. In this context, enantiomerically pure (R)-amethyldopa **41** has been obtained by alkylation of an enolate derived from chiral iminoalaninate **39** and subsequent hydrolysis of product **40** (Scheme 11).²²

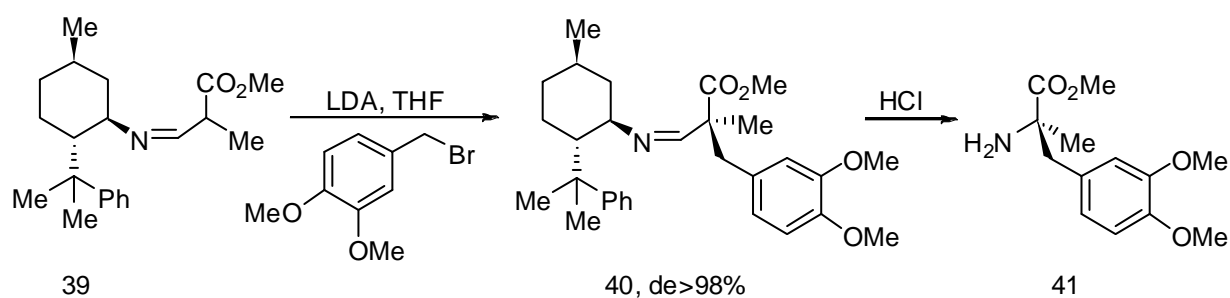

Scheme 11

Aldimines derived from aldehydes with chiral side chain at C3 have been deprotonated and quenched with an alkyl halide to afford the corresponding α -alkylated compounds with different levels of diastereoselectivity, which depend on the structure of the side

²² Meyer, L.; Poirier, J. M.; Duhamel, P.; Duhamel, L. J. *Org. Chem.* 1998, 63, 8094–8905.

gamma (compound 47) alkylated compounds with excellent diastereoselectivity. The α /*gamma* ratios were found to be better using hard electrophiles. γ -alkylated compounds decomposed during alkaline hydrolysis, allowing the recovery of the chiral auxiliary and isolation of the methyl esters of α -alkylated compounds, which were hydrolysed to the free amino acid (Scheme 14).

Scheme 14

Benzylation of substrate 50, derived from (S)-camforsultam and 2-phenyl-2-oxazoline-4-carboxylate, was performed under phase-transfer catalysis conditions.²⁶ The authors obtained optimal results with phosphazene base P2-Et working at -78°C. This methodology was extended to other alkyl halides. Alkylation with active halides led to the corresponding α -alkyl derivative with high yield and diastereoselectivity (Scheme 15).

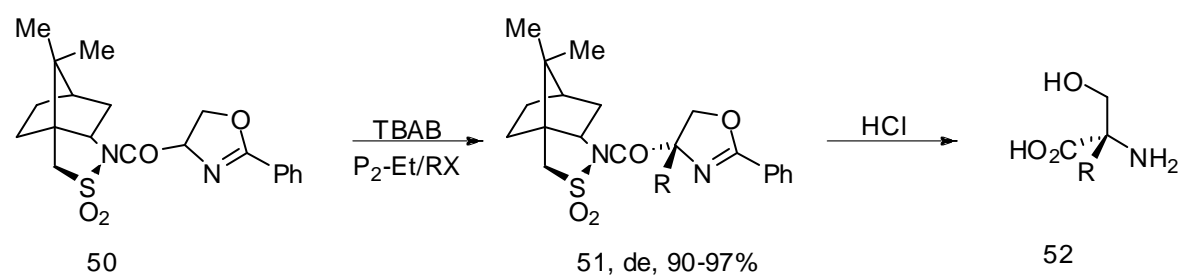

R = Bn, Me, All, $\text{CH}_2=\text{C}(\text{CH}_3)\text{CH}_2$, $4\text{-FC}_6\text{H}_4\text{CH}_2$, 2-naphthylmethyl, $4\text{-CH}_3\text{C}_6\text{H}_4\text{CH}_2$

Scheme 15

Ley et al. have prepared a new chiral glycine synthetic equivalent 53 (with a 1,4-oxazin-2-one ring) from glycidol.²⁷ In general, sequential alkylation of this compound proceeds to give good to excellent yields and excellent diastereoselectivity in the presence of HMPA. This route allowed the synthesis of enantiomerically pure α,α -dialkyl amino acids with different side chains (Scheme 16).²⁸

²⁶ Lee, J.; Lee, Y.-I.; Kang, M. J.; Lee, Y.-J.; Jeong, B.-S.; Lee, J.-H.; Kim, M.-J.; Choi, J.-y.; Ku, J.-M.; Park, H.-g.; Jew, S.-s. *J. Org. Chem.* 2005, 70, 4158–4161.

²⁷ Dixon, D. J.; Harding, C. I.; Ley, S. V.; Tilbrook, M. G. *Chem. Commun.* 2003, 468–469.

²⁸ Harding, C. I.; Dixon, D. J.; Ley, S. V. *Tetrahedron* 2004, 60, 7679–7682.

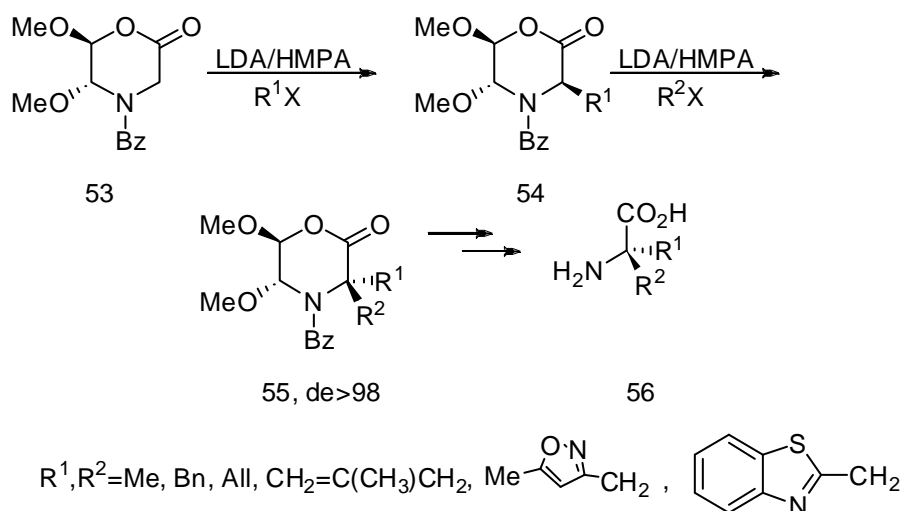

Scheme 16

Schollkopf bis-lactim ethers have been used as chiral precursors in the new synthesis of several α,α -dialkyl amino acids.²⁹

Alkylation of bislactim **53** led to the appropriate synthetic intermediates from which enantiomerically pure novel α -alkyl- α -cyclopentyl glycines were obtained according to [Scheme 45](#). The vinyl moiety in bislactim **54** was submitted to Wacker oxidation conditions to afford methyl ketone **55**, which was then converted into an α -diazoketone by activation with trifluoroethyl trifluoroacetate (TFEA) followed by reaction with tosyl azide. The α -diazoketone **56** in the presence of $\text{Rh}_2(\text{OAc})_4$ gave chemoselective and regioselective intramolecular carbenoid insertion to afford a five-membered ring ([Scheme 17](#)).

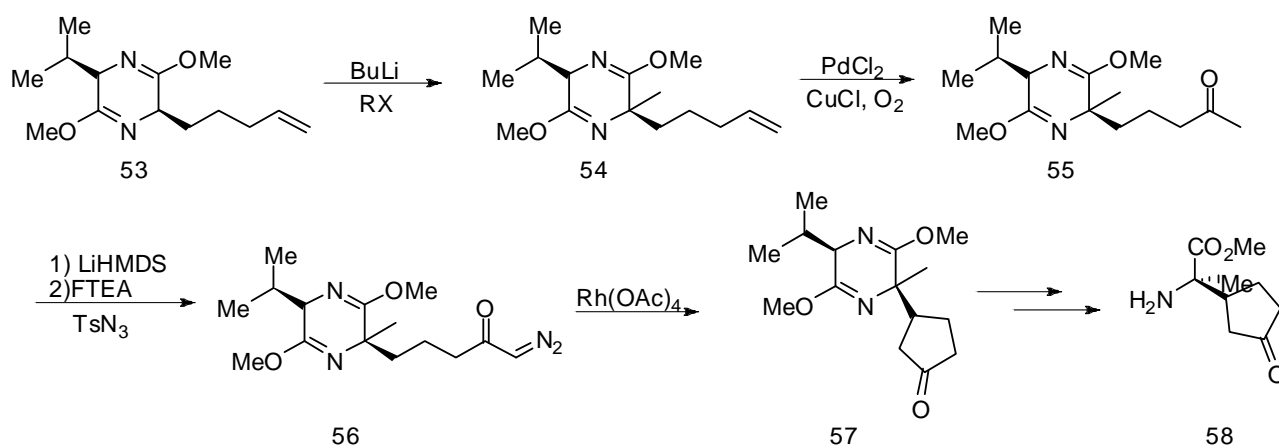

Scheme 17

²⁹ a) Vassiliou, S.; Magriotis, P. A. *Tetrahedron: Asymmetry* 17 (2006) 1754–1757 *Tetrahedron: Asymmetry* 2006, 17, 1754–1757; b) Andrei, M.; Romming, C.; Undheim, K. *Tetrahedron: Asymmetry* 2004, 15, 2711–2717.

2.3- Chiral 2H-azirines and aziridines as building blocks

The use of 3-amino-2H-azirines as synthetic equivalents of α,α -dialkyl amino acids in peptide synthesis using the 'azirine/ oxazolone' method, as developed by Heimgartner,³⁰ has great potential. This approach was used for the preparation and isolation and of new α,α -dialkyl amino acids for use in peptide synthesis.³¹

Alkylation of chiral aziridine-2-carboxylates **59** with different electrophiles could be performed by using an excess of LDA as the base.³² In all cases, the attack of the electrophile occurred with retention of configuration at C2 (Scheme 18).

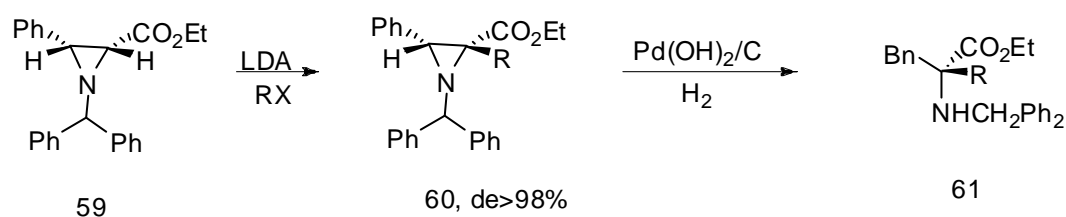

R=Me, all, Bn, MOM

Scheme 18

2.4 Addition of nucleophiles to imines

Cyanide addition to the C=N bond of ketimines bearing a chiral *N*-substituent that acts as a removable chiral auxiliary constitutes an appealing methodology for obtaining α,α -dialkyl amino acids.

The Strecker synthesis has been used in the synthesis of chiral α -monosubstituted α -amino acids from imines derived from aldehydes. However, the application of this approach to the synthesis of α,α -dialkyl amino acids starting from imines derived from ketones has been limited by the low reactivity of the substrate and the low diastereoselectivity of the products. In general, One way to overcome this drawback involves crystallisation-induced asymmetric transformations in which one diastereoisomer selectively precipitates and the other epimerises in solution so that the equilibrium is shifted to the formation of the less soluble diastereoisomer. This approach has been applied to the synthesis of α -methyl dopa by Strecker reaction of the imine

³⁰ Heimgartner, H. *Angew. Chem., Int. Ed.* **1991**, 30, 238–264.

³¹ Brun, K. A.; Linden, A.; Heimgartner, H. *Helv. Chim. Acta* **2002**, 85, 3422–3443.

³² Patwardhan, A. P.; Pulgam, V. R.; Zhang, Y.; Wulff, W. D. *Angew. Chem., Int. Ed.* **2005**, 44, 6169–6172.

derived from 3,4-dimethoxyacetophenone and (R)- phenylglycine amide **62**.³³ On stirring the reaction mixture for 96 h, nearly diastereomerically pure amino nitrile of (**2S**)-**63** was isolated as a solid in 76% yield (Scheme 19).

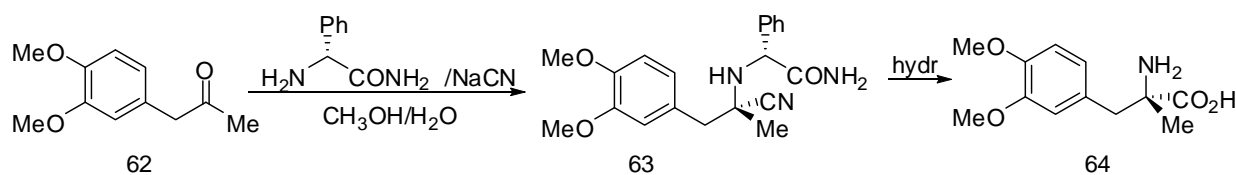

Scheme 19

The use of chiral cyclic ketimines, generated in situ from α acyloxyketones with an amino acid as the acyloxy group, as intermediates in Strecker reactions usually gives the corresponding α -amino nitriles with high stereo selectivity. This approach was developed by Ohfuné³⁴ and has been applied to the asymmetric synthesis of different biologically active α,α -disubstituted amino acids (Scheme 20).

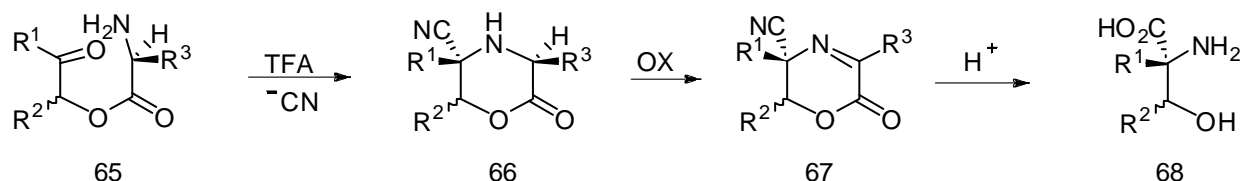

R¹/R²= alkyl, Bn

R³= *i*Pr, *t*Bu, Bn

Scheme 20

Ketimines derived from (R)-2,2-dimethyl-1,3-dioxolan-4-yl methyl ketone add cyanide to afford α,α -dialkyl amino acid precursors.³⁵ The stereoselectivity of the addition depended on the solvent and reaction temperature. In kinetically controlled processes, amino nitriles **70**, with a syn configuration, were obtained preferentially (Scheme 21), whereas in thermodynamically controlled processes anti-amino nitriles were the major products.

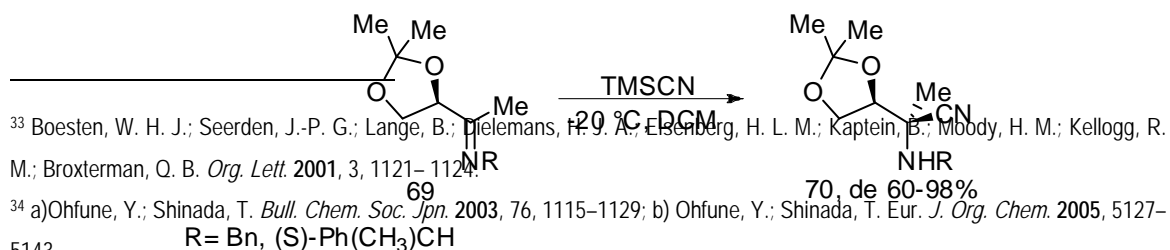

³³ Boesten, W. H. J.; Seerden, J.-P. G.; Lange, B.; Dielemans, F. S. A.; Elzenberg, H. L. M.; Kaptein, B.; Moody, H. M.; Kellogg, R. M.; Broxterman, Q. B. *Org. Lett.* **2001**, *3*, 1121–1124.

³⁴ a) Ohfuné, Y.; Shinada, T. *Bull. Chem. Soc. Jpn.* **2003**, *76*, 1115–1129; b) Ohfuné, Y.; Shinada, T. *Eur. J. Org. Chem.* **2005**, 5127–5143.
R= Bn, (S)-Ph(CH₃)CH

³⁵ Badorrey, R.; Cativiela, C.; Diaz-de-Villegas, M. D.; Diez, R.; Galbiati, F.; Galvez, J. A. *J. Org. Chem.* **2005**, *70*, 10102–10105.

Scheme 21

2.5 Addition of nucleophiles to sulfinimines

Chiral sulfinimines are useful substrates in diastereoselective synthesis as they display excellent reactivity and usually lead to the corresponding products with good diastereoselectivity.³⁶

Chiral (*S*, *R*)-*tert*-butanesulfinyl ketimine **71** (derived from 2-hydroxyacetophenone) is present exclusively as the *Z*-isomer. This compound added cyanide at -20°C with moderate diastereoselectivity in favour of the amino nitrile of (*R,R*)-configuration.³⁷ The major product was isolated and converted into (*S*)- α -phenylserine (**73**) (Scheme 22).

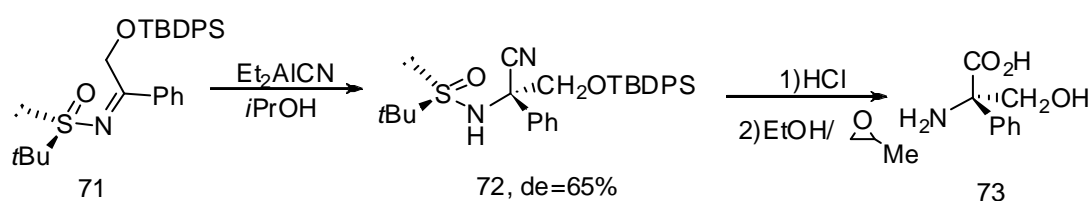

Scheme 22

(*S*, *S*)-*p*-Toluenesulfinimines derived from trifluoropyruvates smoothly reacted with Grignard reagents to provide the corresponding *N*-sulfinyl amino esters with moderate diastereoselectivity.³⁸ On the contrary, reaction of compound **74** with titanium enolates allowed the synthesis of enantiomerically pure α -trifluoromethylaspartic trifluoromethylaspartic acid **76** with good overall yield (Scheme 23).³⁹ Sodium,

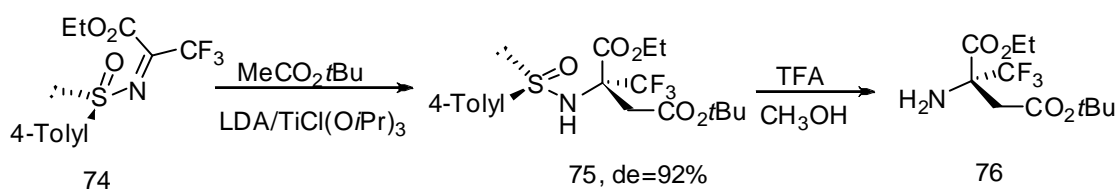

potassium or lithium enolates were less effective in terms of yield and diastereoselectivity.

Scheme 23

³⁶ a) Ellman, J. A.; Owens, T. D.; Tang, T. P. *Acc. Chem. Res.* **2002**, *35*, 984–995; b) Zhou, P.; Chen, B.-C.; Davis, F. A. *Tetrahedron* **2004**, *60*, 8003–8030; c) Davis, F. A.; Zhou, P.; Chen, B.-C. *Chem. Soc. Rev.* **1998**, *27*, 13–18.

³⁷ Avenozza, A.; Busto, J. H.; Corzana, F.; Peregrina, J. M.; Sucunza, D.; Zurbano, M. M. *Synthesis* **2005**, 575–578.

³⁸ a) Bravo, P.; Crucianelli, M.; Vergani, B.; Zanda, M. *Tetrahedron Lett.* **1998**, *39*, 7771–7774; b) Asensio, A.; Bravo, P.; Crucianelli, M.; Farina, A.; Fustero, S.; Garcia-Soler, J.; Meille, S. V.; Panzeri, W.; Viani, F.; Volonterio, A.; Zanda, M. *Eur. J. Org. Chem.* **2001**, 1449–1458.

³⁹ Lazzaro, F.; Crucianelli, M.; De Angelis, F.; Frigerio, M.; Malpezzi, L.; Volonterio, A.; Zanda, M. *Tetrahedron: Asymmetry* **2004**, *15*, 889–893.

2.6 Diastereoselective SN2' substitution

The SN2' displacement of an allylic leaving group in chiral pivalate esters is a stereospecific reaction that has been used in the creation of quaternary stereogenic centres. A stereodivergent approach to α,α -dialkyl amino acids has been developed starting from chiral allylic esters with the appropriate substituents.⁴⁰

The source of chirality in this approach was p-menthane-3- carboxaldehyde **77**, which reacted with propargyl alcohol and organometallic reagents to afford the corresponding diols. In cases where the diastereoselectivity in this reaction was not very good, oxidation of the secondary alcohol and reduction of the resulting ketone gave the desired diol with complete stereoselectivity (**79**, Scheme 24).

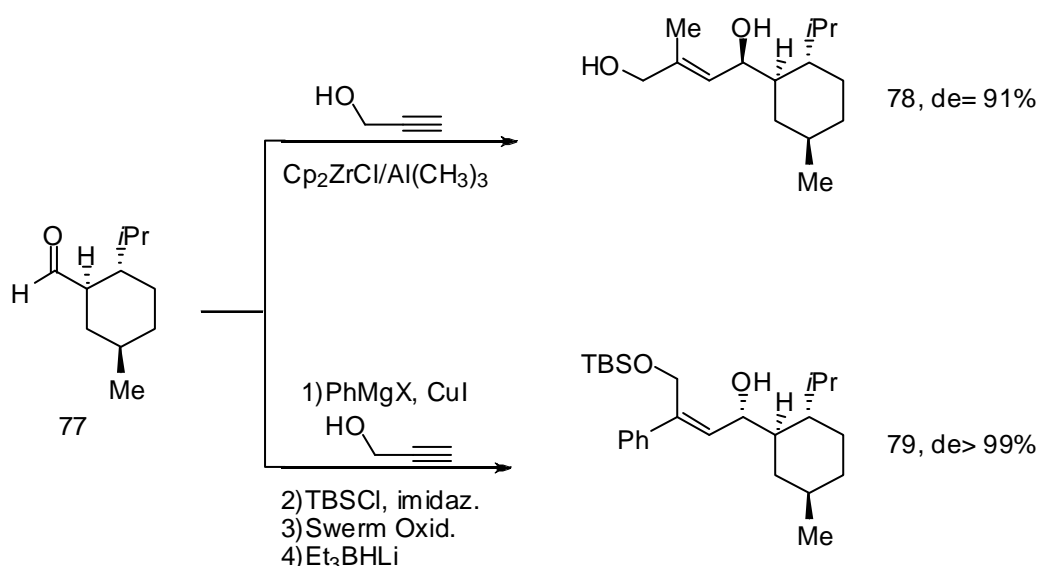

Scheme 24

2.7 Chiron approach

(R)- and (S)-*N*-Boc-*N,O*-isopropylidene serinal (Garner's aldehyde), is one of the most versatile chiral synthons used in the preparation of chiral compounds. α - Methyl homologues **78** can be regarded as ideal compound for the synthesis of α,α -dialkyl amino acids. The oxazolidine ring can act as a masked α -methyl amino acid moiety. Convenient manipulation of the formyl group at C4 in compound **78** led to the efficient

⁴⁰ a) Spino, C.; Gobdout, C. *J. Am. Chem. Soc.* **2003**, *125*, 12106– 12107; b) Spino, C.; Gobdout, C.; Beaulieu, C.; Harter, M.; Mwene-Mbeja, T. M.; Boisvert, L. *J. Am. Chem. Soc.* **2004**, *126*, 13312–13319.

syntheses of several α -methyl amino acids of (R)- or (S)-configuration depending on the configuration of the starting compound. Cleavage of the protection moiety and Jones oxidation of the primary alcohol was the common strategy used to generate the amino acid moiety at the end of the synthesis. Wittig olefination with methyltriphenylphosphonium bromide was the synthetic tool used to introduce the side chain of vinyl alanine⁴¹ **81** and isovaline⁴² **84** (Scheme 25). The Corey-Fuchs strategy for the conversion of a formyl group to an ethynyl group was used to obtain the ethynylalanine **88** (Scheme 25).

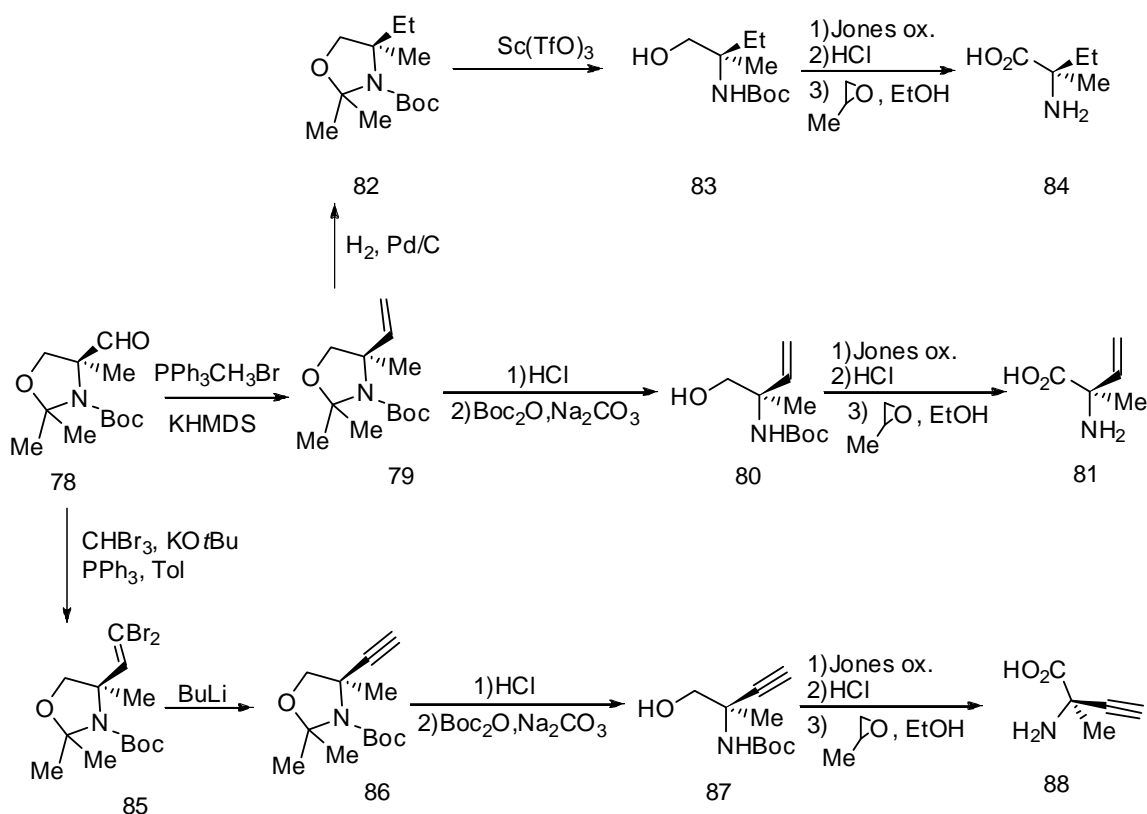

Scheme 25

The addition of nucleophiles to the formyl group led to preferential formation of anti-adducts and the stereoselectivity in the creation of the new stereocentre depended on the reaction conditions.⁴³

⁴¹ Avenzoza, A.; Catiuela, C.; Peregrina, J. M.; Sucunza, D.; Zurbano, M. M. *Tetrahedron: Asymmetry* **1999**, 10, 4653–4661.

⁴² Avenzoza, A.; Catiuela, C.; Corzana, F.; Peregrina, J. M.; Zurbano, M. M. *J. Org. Chem.* **1999**, 64, 8220–8225

⁴³ a) Avenzoza, A.; Catiuela, C.; Corzana, F.; Peregrina, J. M.; Zurbano, M. M. *Tetrahedron: Asymmetry* **2000**, 11, 2195–2204; b) Avenzoza, A.; Busto, J. H.; Corzana, F.; Peregrina, J. M.; Sucunza, D.; Zurbano, M. M. *Tetrahedron: Asymmetry* **2004**, 15, 719–724.

2.8 Enantioselective synthesis: Alkylation under phase-transfer conditions

Amongst the different approaches for the asymmetric synthesis of chiral compounds, that mediated by a chiral catalyst have enormous synthetic utility due to the possibility of producing large quantities of enantioenriched or enantiomerically pure compounds through mediation of a relatively small quantity of chiral catalyst. Several different synthetic routes have been developed for the asymmetric synthesis of α -amino acids using chiral catalysts to induce the preferential formation of one of the two possible enantiomers. As regard the phase-transfer catalysis,⁴⁴ this methodology is largely used to the asymmetric synthesis of α,α -dialkylamino acids and, in particular, ammonium salts derived from cinchona alkaloids are the most common catalysts used in this field of work.

Maruoka et al.⁴⁵ designed a C₂-symmetric chiral quaternary ammonium salt (**89**, Scheme 25) that can be used in the enantioselective alkylation of amino acid Schiff bases as well as in the double alkylation of iminoglycinates, which allows the synthesis of α,α -dialkylamino acids (Scheme 26).

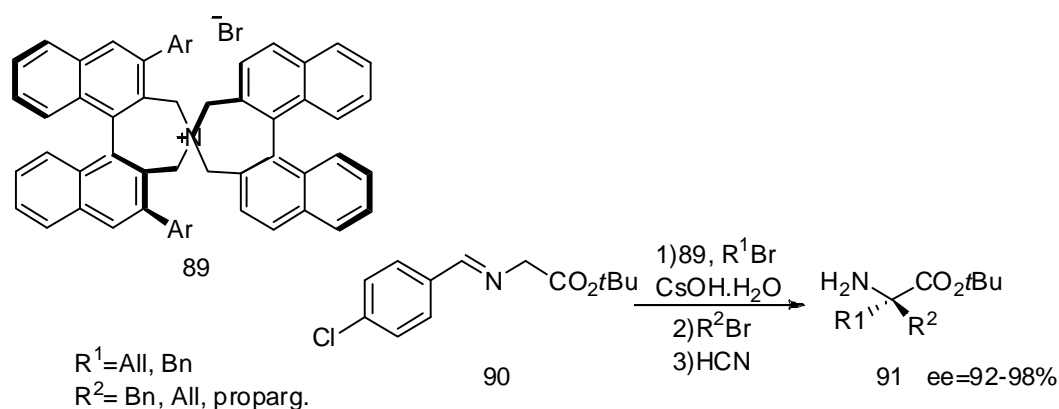

Scheme 26

Double alkylation of glycine allows the synthesis of α,α -dialkylamino acids that contain two side chains different from natural amino acids, with the absolute configuration of the product depending on the order of addition of the halides. Enantiomeric excesses

⁴⁴ a) Nelson, A. *Angew. Chem., Int. Ed.* **1999**, 38, 1583–1585; b) Maruoka, K.; Ooi, T. *Chem. Rev.* **2003**, 103, 3013–3028; c) O'Donnell, M. J. *Acc. Chem. Res.* **2004**, 37, 506–517.

⁴⁵ a) Maruoka, K. *Proc. Jpn. Acad.* **2003**, 79, 181–189; b) Ooi, T.; Takeuchi, M.; Kameda, M.; Maruoka, K. *J. Am. Chem. Soc.* **2000**, 122, 5228–5229; c) Ooi, T.; Takeuchi, M.; Ohara, D.; Maruoka, K. *Synlett* **2001**, 1185–1187.

were very high in both the alkylation of amino acids and double alkylation of glycine. The reactions yields were quite good when air was excluded.⁴⁶

Enantioselective alkylation of 2-phenyl-2-oxazoline-4-carboxylic acid *tert*-butyl ester under phase-transfer catalysis conditions,⁴⁷ using chiral ammonium salt **89** as catalyst, provided α -alkylserine precursors with excellent enantioselectivities (Scheme 27).

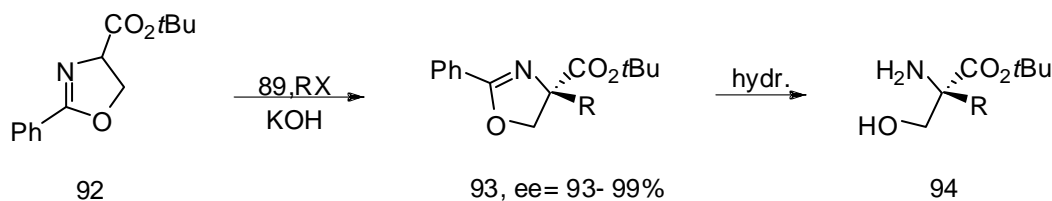

R= Et, All., proparg., Bn, 2-naphtylmethyl,
 $\text{CH}_2=\text{C}(\text{CH}_3)\text{CH}_2$, 4-CNC₆H₄CH₂, 4-CF₃C₆H₄CH₂, 4-
*t*BuC₆H₄CH₂, 4-FC₆H₄CH₂, 4-OMeC₆H₄CH₂

Scheme 27

Phase-transfer catalysed Michael addition using **92** as substrate and **89** as catalyst with ethyl acrylate as the electrophile was not enantioselective. However, when 2-(1-naphthyl)-2-oxazoline-4-carboxylic acid *tert*-butyl ester **95** was used as substrate, derivative **96** was obtained with 97% enantiomeric excess.⁴⁸ Hydrolysis of this compound led to (S)- α - (hydroxymethyl)glutamic acid (Scheme 28).

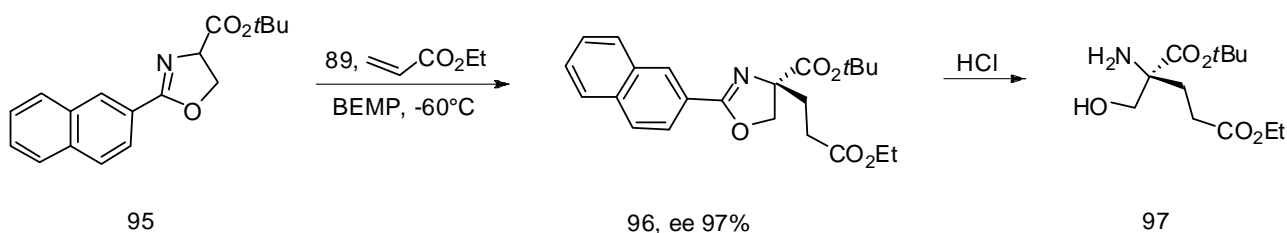

Scheme 28

⁴⁶ a) Maruoka, K. *Proc. Jpn. Acad.* **2003**, 79, 181–189; b) Ooi, T.; Takeuchi, M.; Kameda, M.; Maruoka, K. *J. Am. Chem. Soc.* **2000**, 122, 5228–5229; c) Ooi, T.; Takeuchi, M.; Ohara, D.; Maruoka, K. *Synlett* **2001**, 1185–1187.

⁴⁷ Jew, S.-S.; Lee, Y.-J.; Lee, J.; Kang, M.-J.; Jeong, B.-S.; Lee, J.-H.; Yoo, M.-S.; Kim, M.-J.; Choi, S. H.; Ku, J.-M.; Park, H.-G. *Angew. Chem., Int. Ed.* **2004**, 43, 2382– 2385.

⁴⁸ Lee, Y.-J.; Lee, J.; Kim, M.-J.; Jeong, B.-S.; Lee, J.-H.; Kim, T.-S.; Lee, J.; Ku, J.-M.; Jew, S.-s.; Park, H.-g. *Org. Lett.* **2005**, 7, 3207–3209.

In recent years, other types of chiral phase-transfer catalysts have been used to obtain α,α -dialkylamino acids enantioselectively. For example, Maruoka has recently designed new catalysts of the same type by replacing one (Type A catalysts) or both (Type B catalysts) rigid binaphthyl moieties by more flexible alkyl or aryl groups in order to obtain less lipophilic systems.⁴⁹

Chiral organic compounds capable of functioning as sodium cation chelating agents have proven to be useful as catalysts in enantioselective phase-transfer catalysis reactions. The resulting ion pair formed between the chiral ligand and the substrate is soluble in toluene and provides a rigid complex in the transition state. This phenomenon makes asymmetric induction possible.

TADDOLs (chiral diols obtained from tartaric acid), BINOLs and NOBINs (chiral aminonaphthols) have been tested as promoters in the benzylation of imines derived from alanine isopropyl ester and benzaldehyde. TADDOL **98** and NOBIN **99** (Scheme 29) were found to be the most efficient promoters in terms of activity and asymmetric induction. The level of asymmetric induction was dependent upon the nature of the base and the best results were obtained with NaOH.

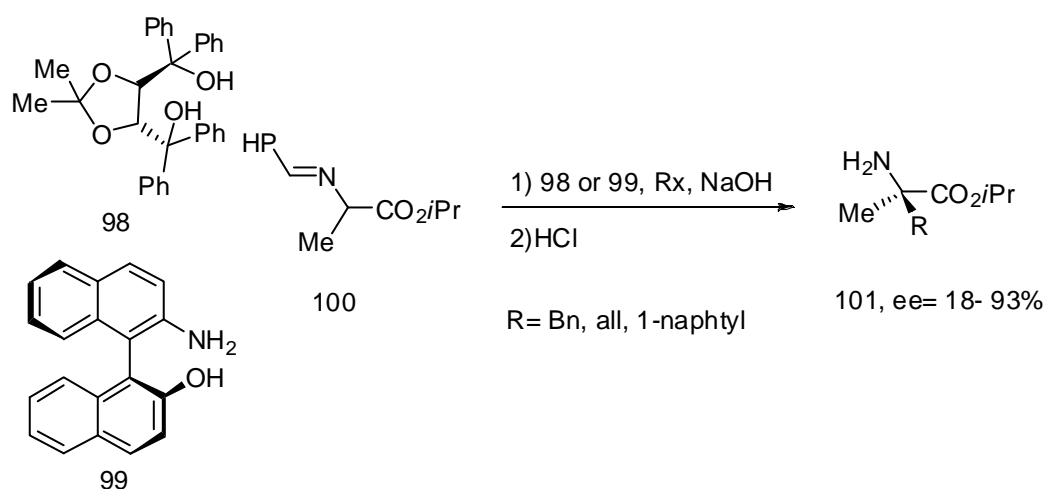

Scheme 29

⁴⁹ a) Kitamura, M.; Shirikawa, S.; Maruoka, K. *Angew. Chem., Int. Ed.* **2005**, *44*, 1549–1551; b) Han, Z.; Yamaguchi, Y.; Kitamura, M.; Maruoka, K. *Tetrahedron Lett.* **2005**, *46*, 8555–8558; c) Belokon, Y. N.; Kochetkov, K. A.; Churkina, T. D.; Ikonnikov, N. S.; Chesnokov, A. A.; Larionov, O. V.; Kagan, H. B. *Russ. Chem. Bull.* **1999**, *48*, 917–923; d) Belokon, Y. N.; Kochetkov, K. A.; Churkina, T. D.; Ikonnikov, N. S.; Vyskocil, S.; Kagan, H. B. *Tetrahedron: Asymmetry* **1999**, *10*, 1723–1728; e) Belokon, Y. N.; Kochetkov, K. A.; Churkina, T. D.; Ikonnikov, N. S.; Chesnokov, A. A.; Larionov, O. V.; Singh, I.; Parmar, V. S.; Vyskocil, S.; Kagan, H. B. *J. Org. Chem.* **2000**, *65*, 7041–7048.

Chiral metal complexes are extremely efficient as catalysts in enantioselective synthesis, as they possess the ability to fix the orientation of the substrate and the chiral ligand in the sphere of the complex, thus providing optimal chiral templates for high asymmetric induction. A chiral metal complex able to chelate metal ions could be an efficient catalyst in asymmetric phase-transfer catalysis. In this context, the use of nickel(salen) and copper(salen) complexes has recently been reviewed.⁵⁰

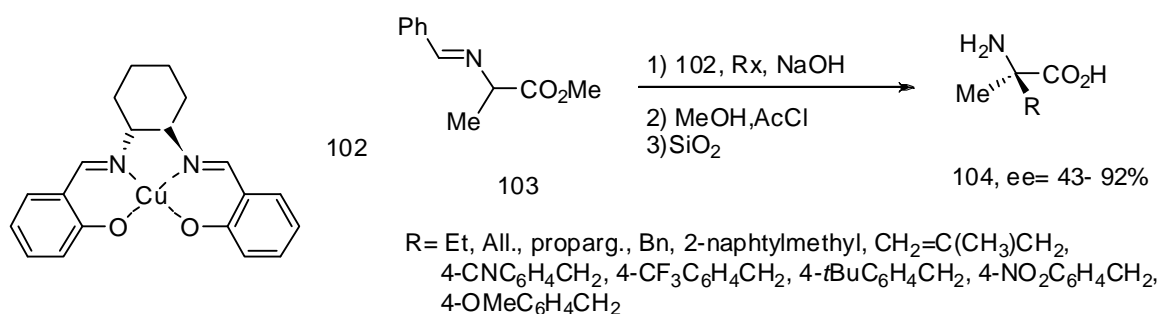

Scheme 30

Salen complex catalysts are active for the benzylation of compound **100** under phase-transfer catalysis conditions.⁵¹ Asymmetric induction with nickel complexes was very low but the performance of the catalysts increased on using copper(salen) complexes (Scheme 30). The procedure has been extended to the synthesis of different α -methyl- α -amino acids, optimizing the use of the easily obtained imine derived from alanine methyl ester and benzaldehyde as the starting material.⁵² The enantioselectivity of the reaction was moderate to good depending on the electrophile. Mechanistic studies⁵³ showed that alkylating agents that are reactive under S_N2 conditions and able to stabilize a charged transition state gave the best results.

⁵⁰ Achard, T. R. J.; Clutterbuck, L. A.; North, M. *Synlett* **2005**, 1828–1847.

⁵¹ Belokon, Y. N.; North, M.; Kublistki, V. S.; Ikonnikov, N. S.; Krasik, P. E.; Maleev, V. I. *Tetrahedron Lett.* **1999**, 40, 6105–6108.

⁵² Belokon, Y. N.; Davies, R. G.; North, M. *Tetrahedron Lett.* **2000**, 41, 7245–7248.

⁵³ Banti, D.; Belokon, Y. N.; Fu, W.-L.; Groaz, E.; North, M. *Chem. Commun.* **2005**, 2707–2709.

2.9 Transition metal-catalysed allylic alkylation

Allylic substitution mediated by a transition metal is a useful reaction in the enantioselective synthesis of chiral compounds when the appropriate combination of transition metal and chiral ligand is used. This methodology has been applied to the synthesis of α,α -dialkylamino acids using different amino acid synthetic equivalents, different transition metals and different chiral ligands.

Chiral ferrocene ligands have been tested in the palladium(II)-catalyzed asymmetric allylic alkylation of imino esters. Compound **105** was the most efficient ligand in the allylation of imino esters derived from alanine and phenylalanine (Scheme 31).⁵⁴ The absolute configuration of the resulting compounds was not determined.

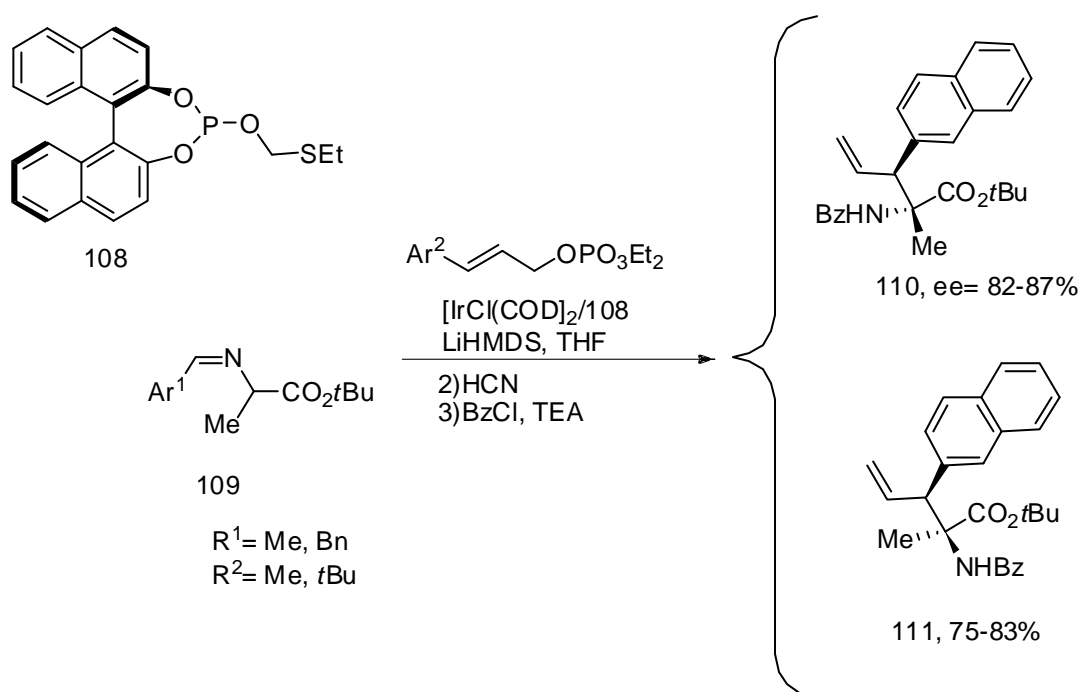

Scheme 31

A combination of $[\text{Ir}(\text{COD})\text{Cl}]_2$ and chiral phosphinate **108** catalysed the enantioselective allylic alkylation of imino alaninates to afford mixtures of compounds **110** and **111**.⁵⁵

⁵⁴ You, S.-L.; Hou, X.-L.; Dai, L.-X.; Cao, B.-X.; Sun, J. *Chem. Commun.* **2000**, 1933–1934.

⁵⁵ Kanayama, T.; Yoshida, K.; Miyabe, H.; Kimachi, T.; Takemoto, Y. *J. Org. Chem.* **2003**, *68*, 6197–6201.

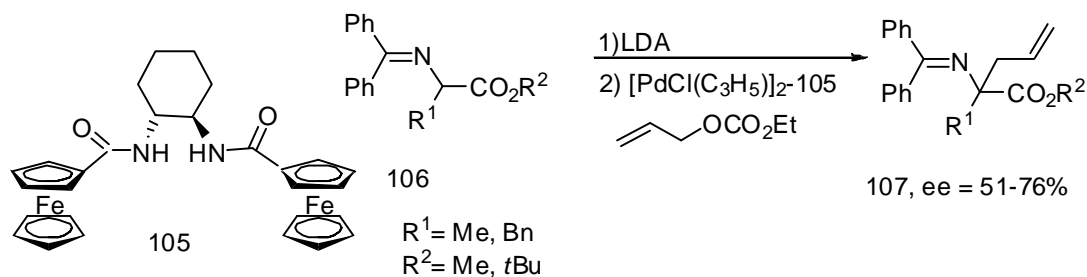

Scheme 32

Diastereoselectivity and enantioselectivities in the formation of compounds **110** and **111** depended on the reaction conditions. The use of THF as the solvent, LiHMDS as the base and the appropriate ratio of reagents gave good diastereoselectivities and enantioselectivities (Scheme 32).

Molybdenum catalysts have been tested to control the regioselectivity of the allylation reaction⁵⁶ and in nearly all cases, the branched products were the only ones obtained and these were formed as single diastereoisomers (Scheme 33).

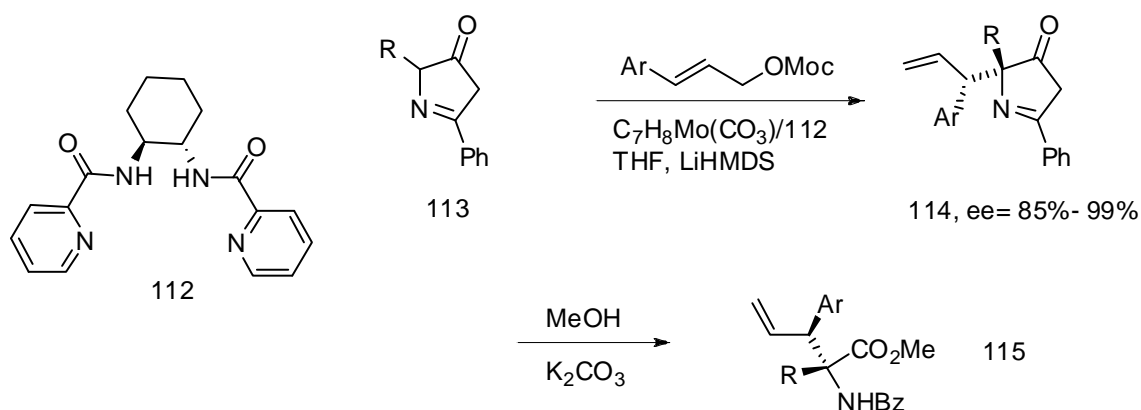

Scheme 33

The Sn(II)-mediated aldol condensation of aldehydes with bislactim ethers derived from diethyl aminomalonate and glycine in the presence of an excess amount of (-)-sparteine afforded preferentially diastereoisomers **117** with good enantioselectivities (Scheme 34).

57

⁵⁶a) Trost, B. M.; Dogra, K. *J. Am. Chem. Soc.* **2002**, *124*, 7256–7257; b) Mosey R. A.; Fisk J. S.; Tepe J. J. *Tetrahedron: Asymmetry* **2008**, *19*, 2755–1762.

⁵⁷ a) Sano, S.; Ishii, T.; Miwa, T.; Nagao, Y. *Tetrahedron Lett.* **1999**, *40*, 3013–3016; b) Undheim K. *Amino Acids* **2008**, *34*, 357–402

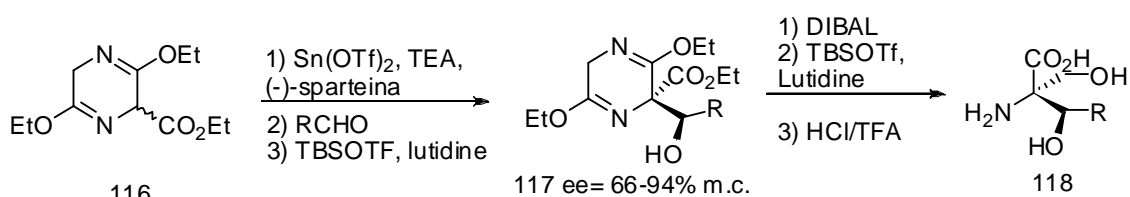

Scheme 34

Chiral derivatives of 4-(dimethylamino)pyridine or 4-(pyrrolidino)pyridine catalyzed the enantioselective rearrangement of *O*-acylated azlactones into *C*-acylated azlactones, in the presence of derivative 120.⁵⁸ The enantioselectivity of the rearrangement depended on the substituent at C2 and on the migrating group at C5. Optimal results were obtained with 2-(4-methoxyphenyl) derivatives as starting compounds and benzyl carbonate as the migrating group. Under optimised conditions, azlactones **121** were obtained in excellent yield and with high enantioselectivity. These compounds are valuable synthetic intermediates in the synthesis of α - α -dialkylamino acids and their derivatives (Scheme 35).

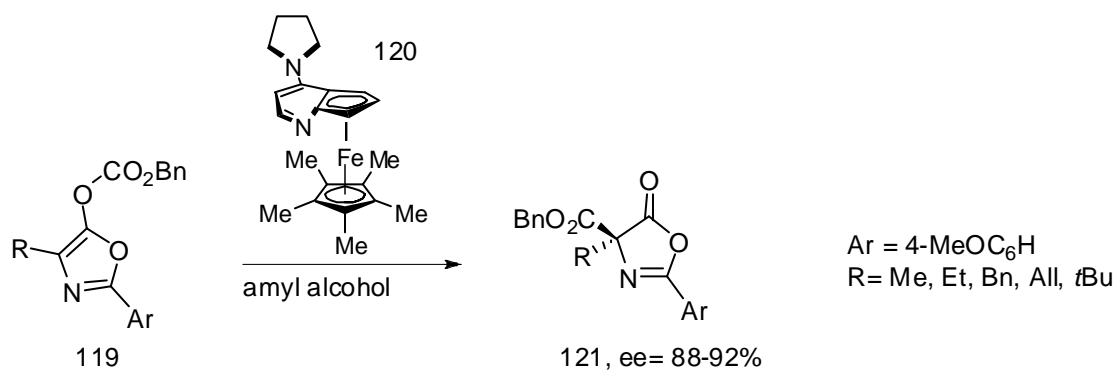

Scheme 35

The catalytic enantioselective Strecker reaction is an attractive methodology for the synthesis of optically active α -amino acids.⁵⁹

The synthesis of α - α -dialkylamino acids using this methodology requires the use of a ketimine as a substrate and a chiral catalyst. Chiral heterobimetallic complexes type

⁵⁸ a) Ruble, J. C.; Fu, G. C. *J. Am. Chem. Soc.* **1998**, 120, 11532–11533; b) Fu, G. C. *Acc. Chem. Res.* **2000**, 33, 412–420.

⁵⁹ Groger, H. *Chem. Rev.* **2003**, 103, 2795–2827. 221. Chavarot, M.; Byrne, J. J.; Chavant, P. Y.; Valle'e, Y. *Tetrahedron: Asymmetry* **2001**, 12, 1147–1150.

M(BINOL)₂Li have been used as catalysts in the enantioselective addition of cyanide to *N*-benzyl imine.⁶⁰

Shibasaki et al. described a general catalytic enantioselective Strecker reaction of ketimines using a chiral gadolinium complex prepared from Gd(OiPr)₃ and ligand 122, derived from D-glucose.⁶¹ The enantioselectivity depended on the *N*-protecting group, the order of the addition of the reagents and the presence of protic additives. Optimal results were obtained using *N*-phosphinoyl imines by adding the substrate to the dried pre-catalyst, followed by solvent and trimethylsilyl cyanide as the cyanide source in the presence of 2,6-dimethylphenol. High enantioselectivities were obtained under these conditions with a wide variety of substrates. Hydrolysis of the resulting amino nitriles led to the corresponding α,α-dialkylamino acids (Scheme 36)

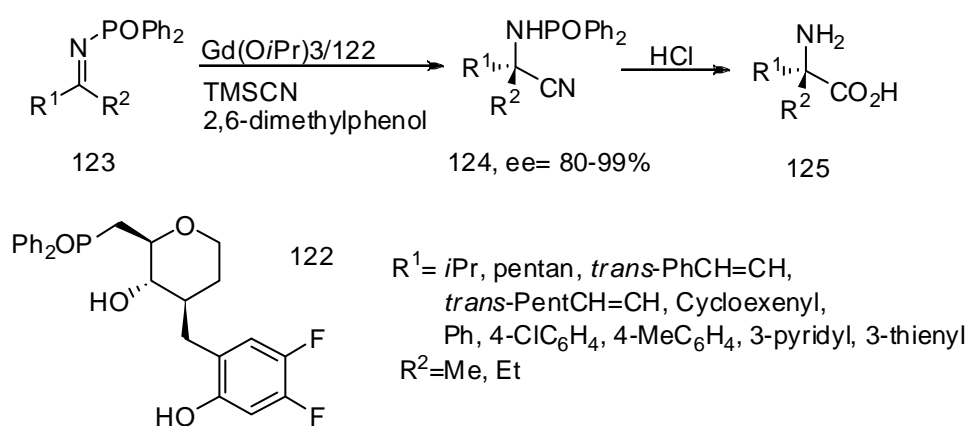

Scheme 36

Chiral Schiff bases derived from (*S,S*)-1,2-diaminocyclohexane have been used as organocatalysts in the enantioselective addition of HCN to ketimines.⁶² Resin-bound catalyst **126** (R₂ = polystyrene beads, R₃=H, X=S) required long reaction times to reach high yields and higher reactivities were observed with soluble catalysts **126** (R₂ = Ph, R₃=H, X=O or R₂=H, R₃ = CH₃, X = O). The use of *N*-allyl imines as substrates led to the formation of unstable amino nitriles, but the use of *N*-benzyl imines gave stable amino

⁶⁰ a) Chavarot, M.; Byrne, J. J.; Chavant, P. Y.; Valle'e, Y. *Tetrahedron: Asymmetry* **2001**, 12, 1147–1150; b) Rueping, M.; Sugiono, E.; Moretha S. A. *Adv. Synth. Catal.* **2007**, 349, 759–764

⁶¹ a) Masumoto, S.; Usuda, H.; Suzuki, M.; Kanai, M.; Shibasaki, M. *J. Am. Chem. Soc.* **2003**, 125, 5634–5635; b) Kato, N.; Suzuki, M.; Kanai, M.; Shibasaki, M. *Tetrahedron Lett.* **2004**, 45, 3147–3151.

⁶² a) Vachal, P.; Jacobsen, E. N. *Org. Lett.* **2000**, 2, 867–870; b) Vachal, P.; Jacobsen, E. N. *J. Am. Chem. Soc.* **2002**, 124, 10012–10014.

nitriles, generally with high enantioselectivities. In cases where compounds **128** are crystalline, a single recrystallisation led to enantiomerically pure compounds. Enantiomerically pure α -methylphenylglycine has been obtained by *N*-formylation (to avoid decomposition), hydrolysis and *N*-debenzylation (Scheme 37).

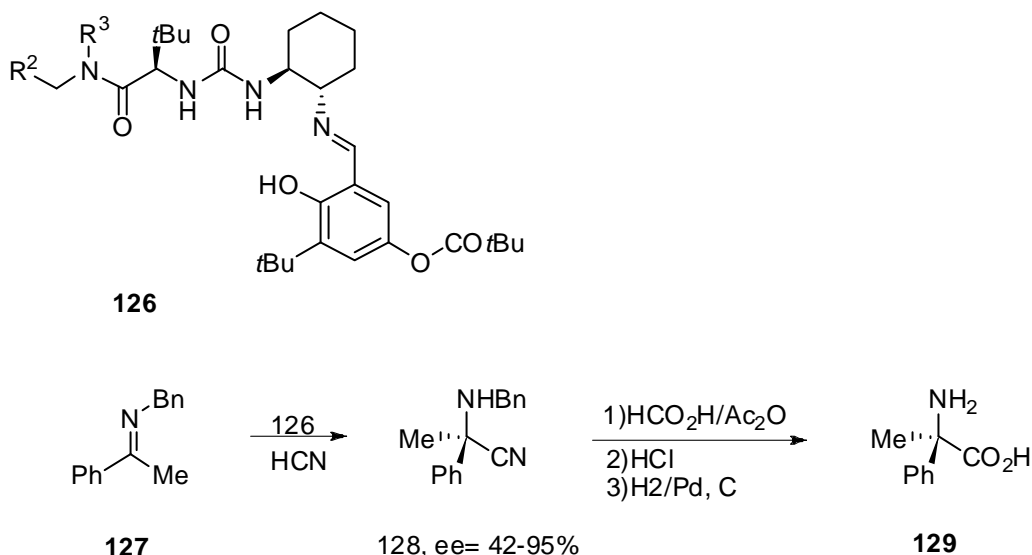

Scheme 37

The addition of Mannich bases to the C=N bond of imines has enormous utility for the synthesis of nitrogen-containing compounds in general and α -amino acids in particular. In this context, Jorgensen et al. have developed enantioselective Mannich reactions starting from cyclic α -ketimino esters in which the anchoring of the protecting group favours their reaction with the nucleophile. Cyclic ketimino esters **130** reacted with isobutyraldehyde in the presence of secondary amines (chiral (S)-1-(2-pyrrolidinylmethyl)pyrrolidine gave the best results) using diethyl ether as the solvent to enantioselectively afford α,α -dialkylamino acid precursor **131**.⁶³ (Scheme 38).

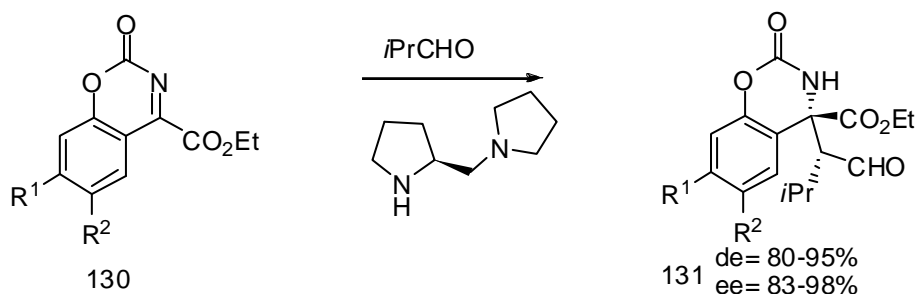

Scheme 38

⁶³ Zhuang, W.; Saaby, S.; Jorgensen, K. A. *Angew. Chem., Int. Ed.* 2004, 43, 4476-4478.

3- Memory of chirality

The phenomenon of the 'Self-Induction of Chirality' (widely known as "Memory of chirality, Moc") consists in the asymmetric reaction of substrates in which the chirality of the starting materials is preserved, despite the formation of apparently achiral intermediates, through the formation of configurationally labile intermediates (typically enolates) during the transformation (Figure 1).⁶⁴

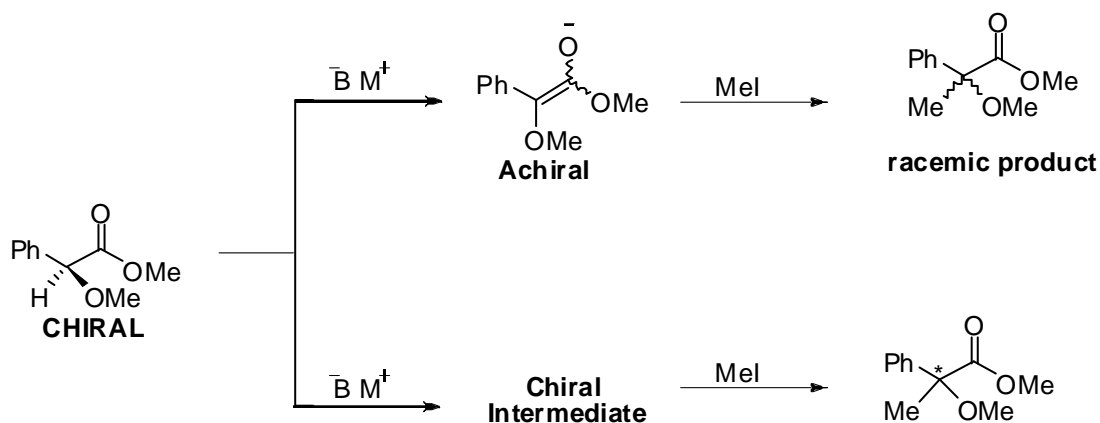
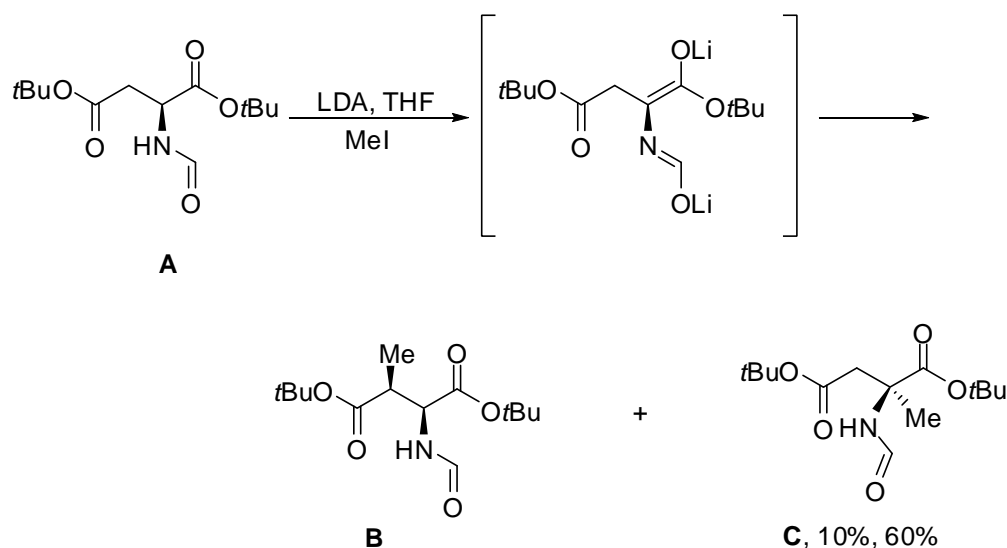

Figure 1

The first example of this kind of reaction was observed by Seebach.⁶⁵ The α -alkylation of β -heterosubstituted carbonyl compounds leads to a surprising result in the case of L-(+)-*N*-formylaspartic acid di-*tert*-butyl ester: the authors isolated a mixture of β - and α -substituted aspartic acid derivatives **B** and **A** in ratio 7:2. The *erythro*-isomer of **B** was formed stereospecifically; moreover, **C** was formed in 60% *ee* (Scheme 1).



Scheme 1

⁶⁴ a) Kawabata, T.; Fujii, K. *Top. Stereochem.* 2003, 23, 175–205; b) Fujii, K.; Kawabata, T. *Chem. Eur. J.* 1998, 3, 373–376

⁶⁵Seebach, D.; Wasmuth, D. *Angew. Chem. Int. Ed.* 1981, 11, 971.

An enolate, which does not contain stereogenic centres is not always achiral, despite its planar nature; in fact, it can possess axial or planar chirality, since particularly crowded double bonds can behave like aromatic rings. (Figure 2)

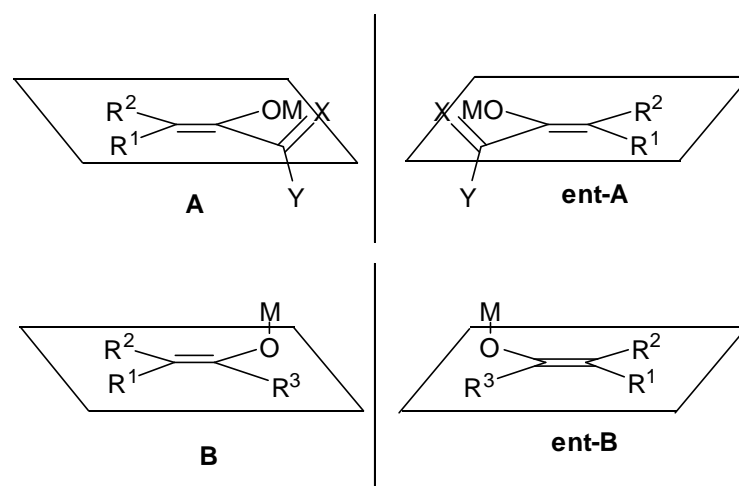
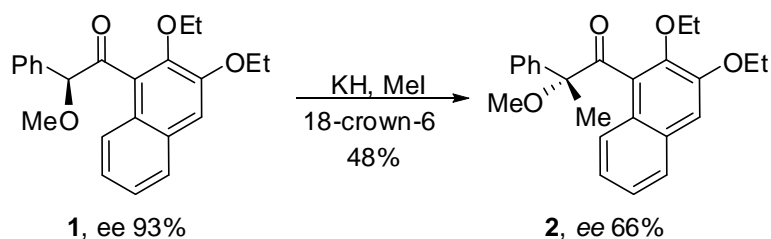

Figure 2

The enantiomeric forms **A** and **ent-A**, and **B** and **ent-B**, under normal conditions are not differentiated because of the rapid equilibrium between them. They may be differentiated from each other at an extremely low temperature or by the introduction of specific structural constraints into the molecule (such as changing 2,2'-dihydroxybiphenyl to the corresponding binaphthalene). Thus, this is a phenomenon in which the information on chirality in the original system is kept in a reactive intermediate for a limited period of time.

Kawabata and Fuji have introduced this concept in 1991:⁶⁶ in the below mentioned example, the authors showed that treatment of the α -alkoxy naphthyl ketone **1** (93% enantiomeric excess) with potassium hydride and methyl iodide in the presence of 18-crown-6 afforded **2** in 66% enantiomeric excess without any additional chiral source (Scheme 2).

⁶⁶ Kawabata, T.; Fuji, K. *J. Am. Chem. Soc.* **1991**, *113*, 9694-9696.



Scheme 2

The obtained results suggested the formation of a chiral enolate intermediate in a nonracemic form. The authors proposed that the reaction occurs via the enolate **3**, whose structure is reminiscent of the atropisomeric 1,1-binaphthyls. In accord with this hypothesis, the *O*-alkylated product **4** was also detected in the reaction mixture with 65% enantiomeric excess. At room temperature, **4** was found to racemize with half-life time of 53 minutes, corresponding to a rotation barrier of 22.6 kcal/mol; the phenyl analogue of **1** subjected to the same reaction conditions, gave the racemic product.

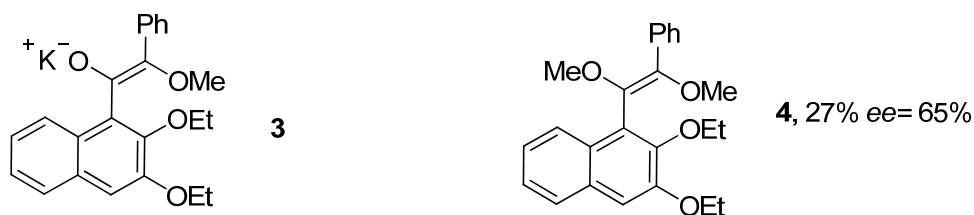

Figure 3

In order to extend this strategy, Kawabata studied the α -alkylation of the enolates generated from α -amino acids. In fact, an enolate derived from an optically active amino acid derivative, may not racemize under basic conditions. Here are reported (Figure 4) three different species of enolates which could furnish an optically active product:

- enolate **C**, which has axial chirality across the carbon-nitrogen bond. This kind of enolates is expected if R^3 is different from R^4 ;
- **D**, which has planar chirality due to the enolate plane and the metal cation, stabilized by coordination with a substituent on the nitrogen;
- **E** is an enolate with a chiral nitrogen atom, where tight coordination of the nitrogen atom to a metal cation creates a stereogenic nitrogen atom, not allowing the pyramidal inversion.

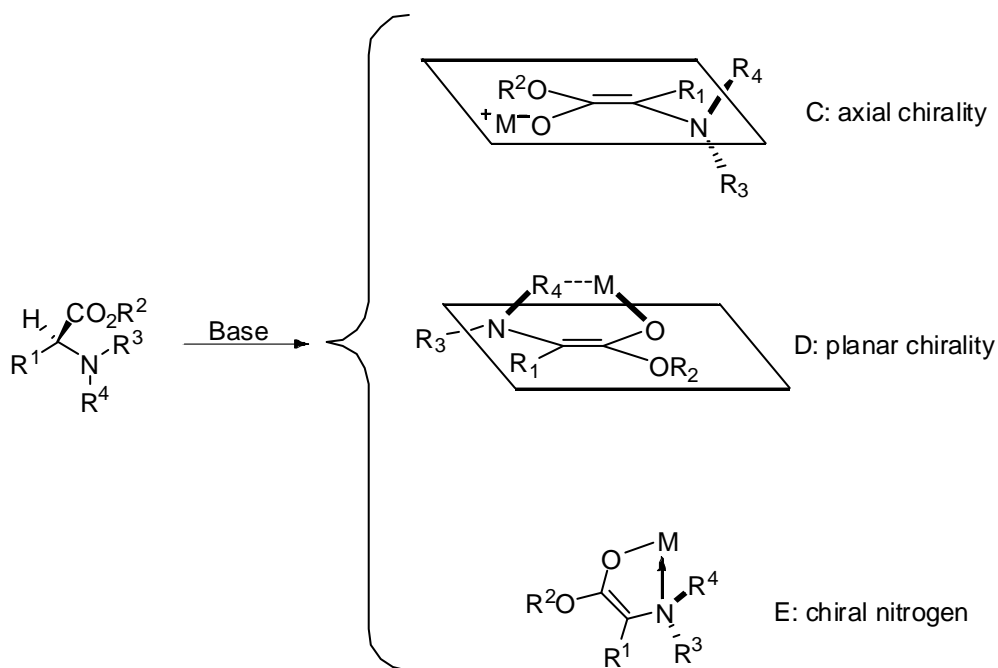
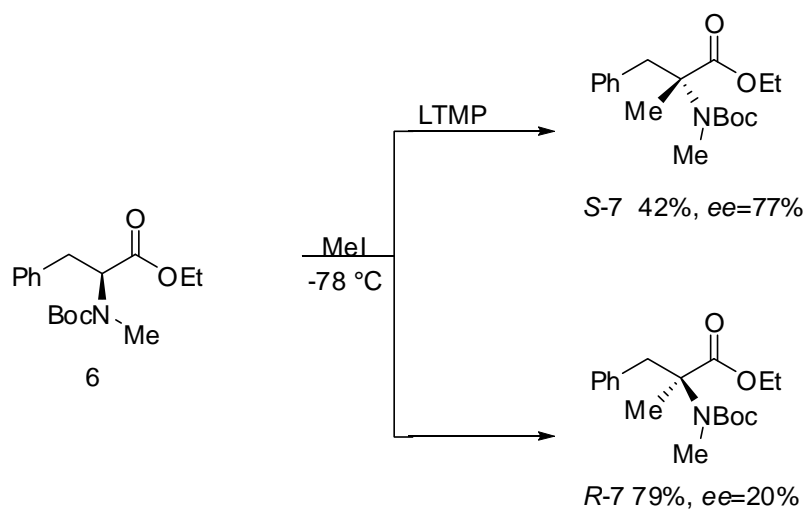

Figure 4

Kawabata et al. proposed a study on the chirality transfer using as a starting amino acid the *N*-Boc-phenylalanine 6 ethyl ester.⁶⁷ Non-racemic products were obtained, the best enantiomeric excess being obtained by using LiTMP as a base. Even more interestingly, KHMDS gave a predominance of the inversion product (20% *ee*), suggesting the existence of two pseudo-enantiomeric transition states (Scheme 3).



Scheme 3

⁶⁷ Kawabata, T.; Wirth, T.; Yahiro, K.; H. Suzuk; Fuji, K. *J. Am. Chem. Soc.* **1994**, 116, 10809-10807;

In order to improve the yields and enantioselectivity of this process, the authors screened a series of substituents on the nitrogen moiety of phenylalanine derivative **8a**.⁶⁸ They found that substrates bearing *tert*-butoxycarbonyl (Boc) and methoxymethyl (MOM) groups gave the best results (Table 1, entry 1).

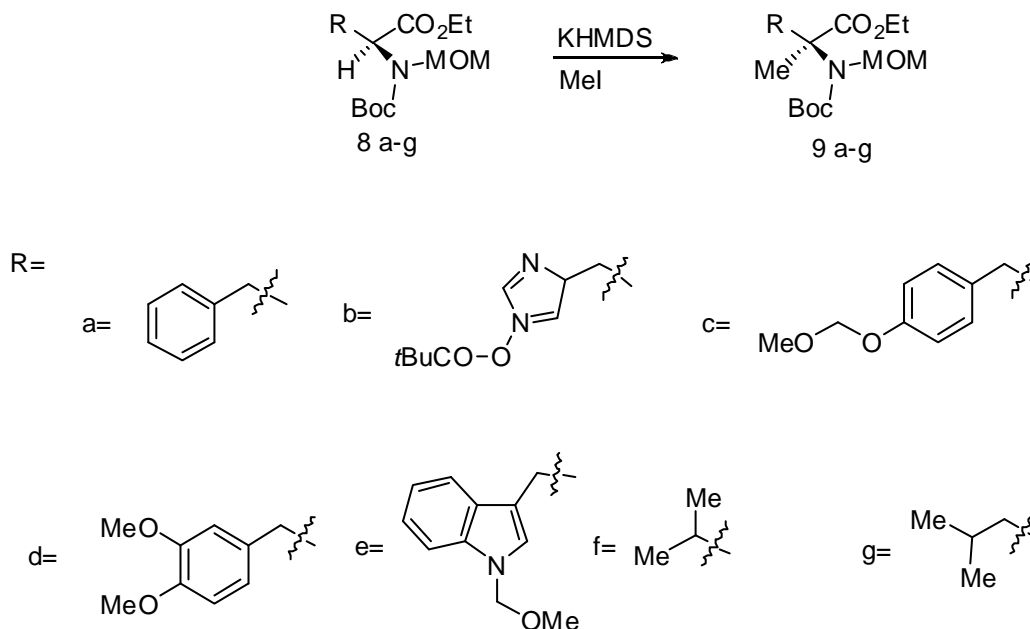

Table 1. α -Alkylation of amino acid derivatives

entry	R	yield (%)	ee (%)
1	a	96	81
2	b	83	93
3	c	94	79
4	d	95	80
5	e	88	76
6	f	81	87
7	g	78	78

Kawabata et al. have also applied the best reaction conditions to amino acid derivatives different from phenylalanine **8** (Table 1). In each case, they obtained quite good yields and enantioselectivity: moreover, differently from the *N*-methyl derivative **7** (Scheme 3), Boc and MOM protective groups are simply removed by treatment with aqueous HCl, affording the corresponding α -methyl- α -amino acids in 51–86% yields. The degree of

⁶⁸ Kawabata, T.; H. Suzuki; Wirth, T.; Nagae, Y.; Fuji, K. *Angew. Chem. Int. Ed.* **2000**, *12*, 2155- 2158

asymmetric induction in the α -methylation indicates that MOM and Boc groups on the nitrogen atom have a decisive effect on the stereochemical course of the reaction.

Fuji and Kawabata addressed their study to the α -alkylation of *L*-isoleucine and *D*-alloisoleucine derivatives **10** and **13** to investigate the influence of an additional chiral centre (Scheme 4).⁶⁹ Amino esters **10** and **13** have the same absolute configuration at C₃ and opposite configurations at C₂. When the *N*-MOM ethyl esters **10** and the *N*-Boc ethyl esters **13** were subjected to the standard alkylation condition, both the corresponding methylated compounds **12** and **15** were obtained in excellent diastereoselectivities (93% and 86% diastereoisomeric excess respectively). Thus, the stereochemical course of deprotonation/methylation of **10** and **13** appears to be controlled by the chirality at C₂: in fact, if the chiral information at C₂ had been lost during enolate formation, α -methylation would have given products with identical diastereomeric composition via a common enolate intermediate. These results suggest the formation of diastereomeric enolate intermediates such as **11** and **14**.

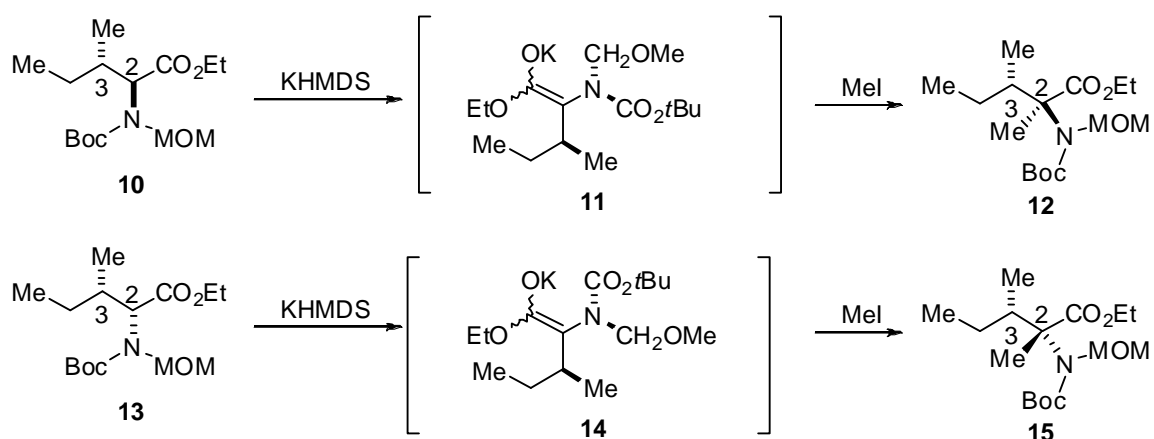

Scheme 4

As regards the reaction mechanism, during the years, Fuji and Kawabata have carried out a number of mechanistic investigations. For the deprotonation/alkylation of *N*-Boc, *N*-Me amino acid esters **16**, the authors considered several mechanistic scenarios (Figure 5):

⁶⁹ Kawabata, T.; H. Suzuki; Wirth, T.; Nagae, Y.; Fuji, K. *Org. Lett.* 2000, 2, 3883- 3885

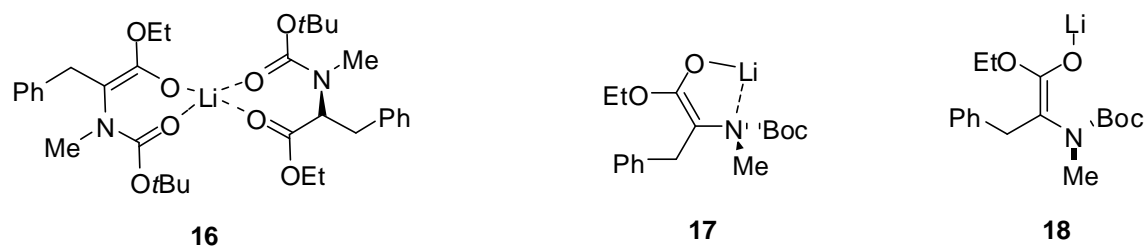
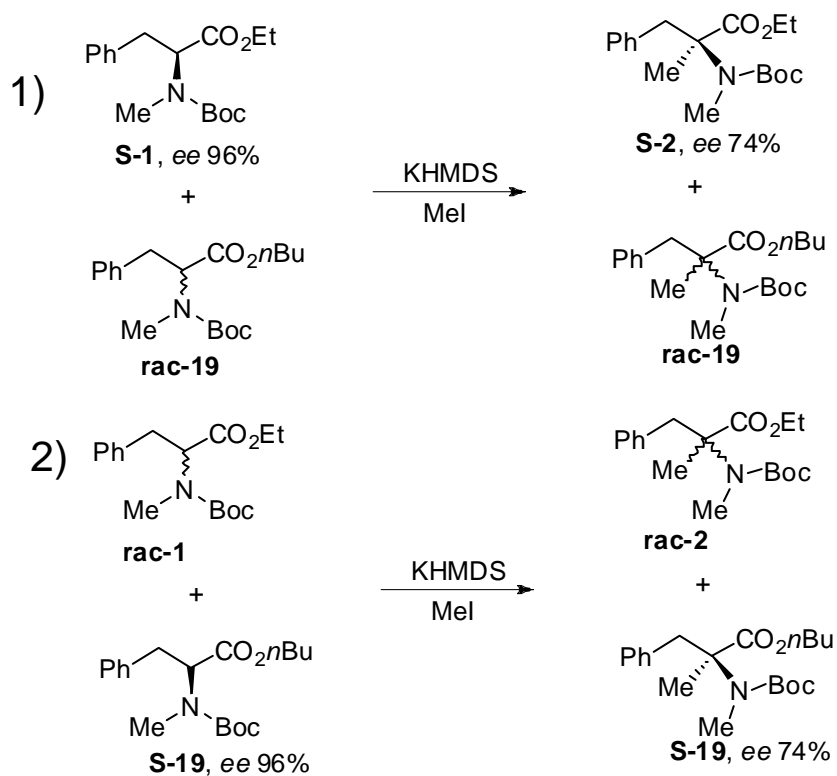

Figure 5

Asymmetric induction could arise from: a chiral enolate/ starting material aggregate **16**; a specie **17** with a chiral *N* atom; an axially chiral enolate **18**.

To rule out the presence of an aggregate such as **16**, the authors conducted a crossover experiment (Scheme 5).⁷⁰



Scheme 5

A mixture of optically pure **1** and racemic **19** were subjected to deprotonation with LiTMP at -78°C followed by addition of methyl iodide, to afford optically active **2** (74% ee, 26% yield) and racemic **19** (30% yield). The same treatment of a 1:1 mixture of racemic **1** and optically active **19** afforded the racemic **2** (17% yield) and optically active **19** (71%

⁷⁰ Kawabata, T.; Wirth, T.; Yahiro, K.; H. Suzuk; Fuji, K. *J. Am. Chem. Soc.* **1994**, 116, 10809-10807

ee, 24% yield). These observations indicate that **16** (Figure 5) does not make a significant contribution to the asymmetric induction.

In their opinion, the most suitable intermediate is compound **18** (Figure 5). As a confirmation, Fuji and Kawabata reported the isolation of the (*Z*)- and (*E*)-TBS ketene acetals **20** (Figure 6).⁷¹

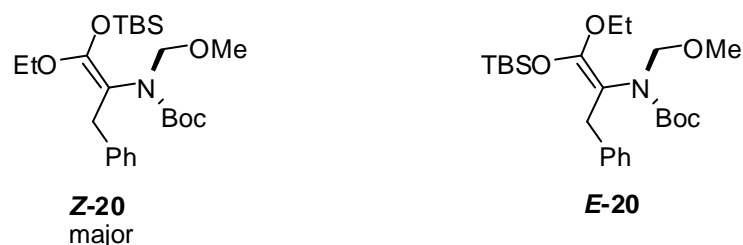
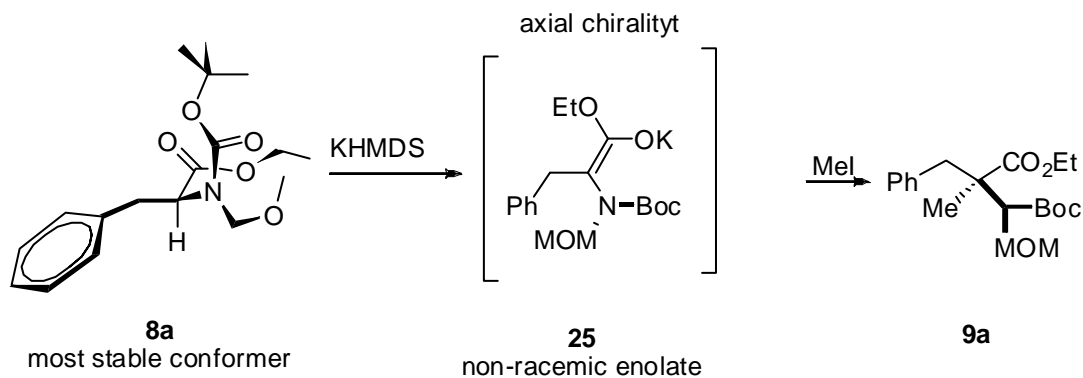

Figure 6

The methylene protons of the MOM groups are diastereotopic in both isomers of **20**, indicating restricted rotation of the C₂-N bond. The rotational barrier of the C₂-N bond in the major isomer **Z-20** was determined to be 16.8 kcal/mol and it corresponds to a racemization half-life of seven days at -78°C.

For this reason the authors proposed that deprotonation of **8a** occurs through the most stable conformer **25** (Scheme 6).



Scheme 6

Kawabata found support for the presence of an axially chiral enolate in both deprotonation/alkylation of both substrates **21** and **22** (Figure 7).

⁷¹ Kawabata, T.; Suzuki, H.; Nagae, Y.; Fuji, K. *Angew. Chem. Int. Ed.* **2000**, *39*, 2155.

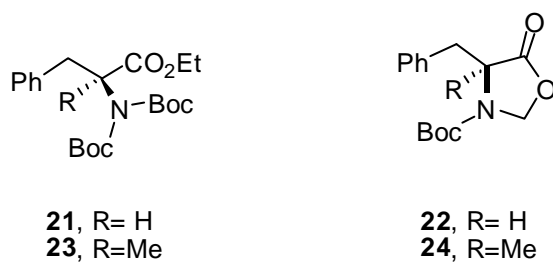

Figure 7

Deprotonation/methylation of enantiopure **21** and enantiopure **22** gave racemic **23** and **24**, because of the formation of an *achiral* enolate: in fact, the presence of two identical Boc protecting groups in compound **21** rule out the possibility of chirality on the N-C₂ axis. In the case of **22** the five-membered ring prevents the N substituents from rotating out of the enolate plane to attain axial dissymmetry.

In the last few years, Kawabata et al. have also applied the concept of autoinduction of chirality to the synthesis of cyclic amino acids.⁷² They designed a series of *N*-Boc-*N*- ω -bromoalkyl- α -amino acid derivatives **26a-h** for asymmetric intramolecular cyclization (Table 2).

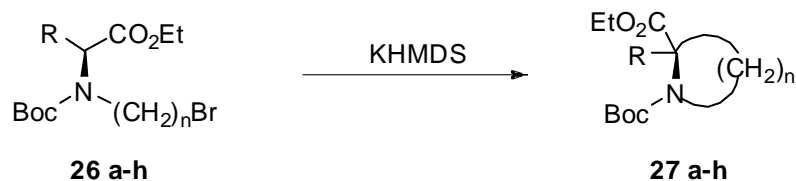

Table 2. synthesis of cyclic amino acids

Entry		n	R	yield (%)	e.e. (%)
1	a	3	PhCH ₂	94	98
2	b	3	4-EtO-C ₆ H ₄ -CH ₂	95	97
3	c	3	MeSCH ₂ -CH ₂	92	97
4	d	3	Me ₂ CH	78	94
5	e	3	CH ₃	91	95
6	f	2	PhCH ₂	61	95
7	g	4	PhCH ₂	84	97
8	h	5	PhCH ₂	31	83

⁷² a) Kawabata, T.; Kawakami, S.; Majumdar, S. *J. Am. Chem. Soc.* **2003**, *125*, 13012; b) Kawabata, T.; Moriyama, K; Kawakami, S.; Tsubaki, K. *J. Am. Chem. Soc.* **2008**, *130*, 4153- 4157

In each case, compounds **27** were obtained in quite good enantiomeric excess and fairly yields. The chirality of the starting amino acids **26a-h** was preserved during enolate formation and subsequent cyclization, giving enantiomerically enriched azacyclic quaternary amino acids, with retention of configuration, as found for the acyclic quaternary amino acids. For this reason, Fuji and Kawabata proposed a similar mechanism to that of **8a** (Scheme 7). In this case, a conformational study identified two stable conformers of compound **26a** of similar energy: **A** and **B**. Deprotonation of **B** is disfavoured because of a steric interaction between KHMDS and the *N*-Boc group. On the other hand, deprotonation of **A** is favoured and gives axially chiral nonracemic enolate **X**, which then cyclizes to give the retention product **27A**.

With the aim of shift the equilibrium, making dominant the transition state **Y**, thus extending this procedure to the synthesis of inversion compounds, the authors investigated the asymmetric cyclization of **26** changing the cation of the employed base.⁷³ The best result of **27B** (93%, 91% enantiomeric excess) was obtained using as a cation Li⁺, which is the smallest metal cation.

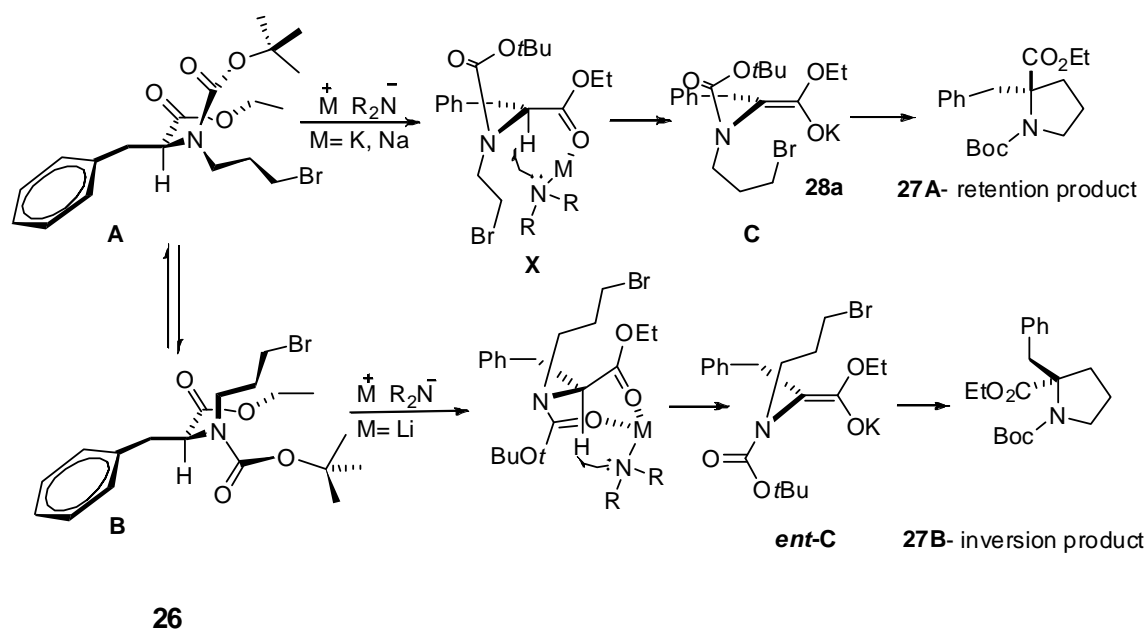

Scheme 7

The protocol for enantio-divergent cyclization was applied to intramolecular conjugate addition of chiral enolates. Treatment of the alanine derivative **28** with KHMDS in DMF-

⁷³ Kawabata, T.; Matsuda, S.; Kawakami, S.; Monguchi, D.; Moriyama, K. *J. Am. Chem. Soc.* **2006**, *128*, 15394-15395.

THF (1:1) at -78°C gave **29** as a single diastereomer in 95% ee (Scheme 8, (path A) The absolute configuration assignment of **29** was based on the stereochemical course of asymmetric intramolecular conjugate addition via memory of chirality. Treatment of **28** with LTMP in THF at 0°C gave *ent*-**29** as a single diastereomer in 91% ee.

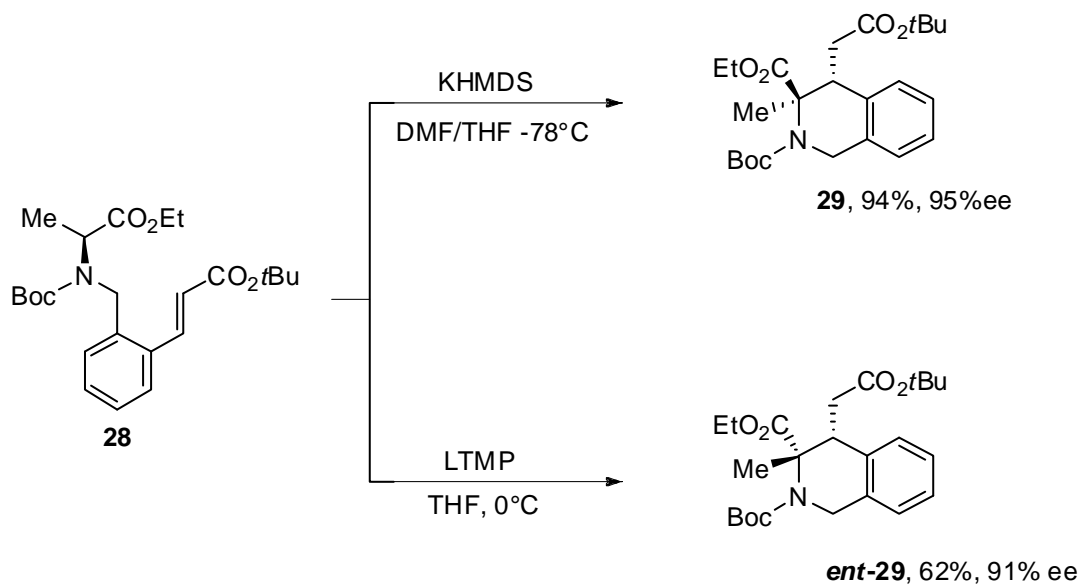

Scheme 8

4- Synthesis of α -quaternary prolines

Several methods for the stereoselective synthesis of quaternary prolines have been reported, typically relied on the synthesis of the pyrrolidinic ring or the α -functionalization of commercial inexpensive L-proline itself.⁷⁴

Furthermore, in the field of carbon-carbon bond formation, synthetic strategies based on sigmatropic rearrangements are one of the most interesting method to obtain α -quaternary prolines.

In the last few years, West and Glaeske reported a study on chirality transfer in [1,2]-Stevens rearrangement of the diastereomerically pure cyclic ammonium salt methyl ester **1** (Table 1, entry 1).⁷⁵ Using tetrahydrofuran as solvent under the action of potassium *tert*-butylate, the quaternary proline ester **2** was isolated with fairly good enantioselectivity.

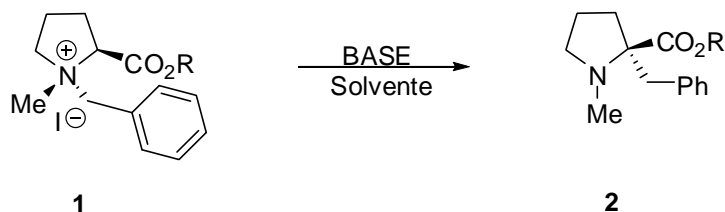

Table 1.

Entry	R	Base	Solvent	T (°C)	t (h)	2 (%)	ee (%)
1	Me	<i>t</i> BuOK	THF	rt	1.5	73	54
2	<i>t</i> Bu	<i>t</i> BuOK	DCM	rt	3	80	72
3	<i>t</i> Bu	50% KOH	DCM	-10	24	45	86
4	<i>t</i> Bu	KOH	DCM	-10	24	52	94
5	<i>t</i> Bu	CsOH	DCM	-10	24	88	84
6	<i>t</i> Bu	CsOH	DCE	-10	24	73	92

This technique was further improved by Tayama et al. by employing solid-liquid biphasic reaction conditions (entry 2,5); the best yield and enantioselectivity were reached by using caesium hydroxide in dichloroethane (entry 6).⁷⁶ It has also been

⁷⁴ Recent review: ^{a)} Karoyan, P.; Sagan, S.; Lequin, O.; Quancard, J.; Lavielle, S.; Chassaing, G. "Substituted Prolines: Syntheses and Applications in Structure-Activity Relationship Studies of Biologically Active Peptides, in *Targets in Heterocyclic Systems - Chemistry and Properties* (Eds: O. A. Attanasi, D. Spinelli), Royal Society of Chemistry, Cambridge, **2005**, Vol. 8, pp. 216-273; ^{b)} Cativiela, C.; Díaz-de-Villegas, M. D. *Tetrahedron: Asymmetry* **2000**, *11*, 645-732 ^{c)} Cativiela, C., Calaza, M. I. *Eu. JoC* **2008**, *11*, 3427-3448

⁷⁵ Glaeske, K. W.; West, F. G. *Org. Lett.* **1999**, 31-33.

⁷⁶ Tayama, E.; Orihara, E.; Kimura, H. *Org. Biomol. Chem.* **2008**, 3673-3680.

noticed that the level of N-C chirality transfer depends not only on the reaction conditions but also on the *N*-benzyl moiety (Table 2).

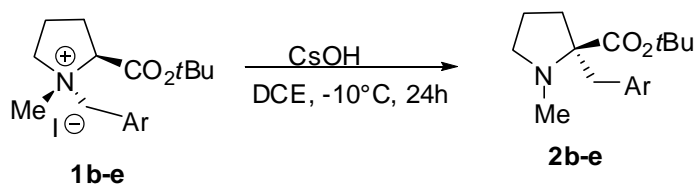
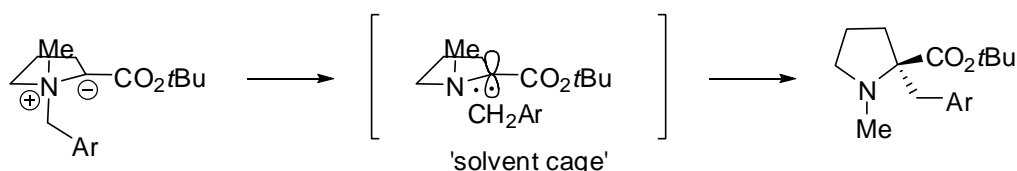

Table 2.

Ar	2	(%)	<i>ee</i> (%)
4-Me-Ph	2b	77	84
4-MeO-Ph	2c	56	86
4-F-Ph	2d	69	90
4- <i>t</i> BuOCOPh	2e	42	99

This rearrangement is assumed to proceed by a radical cleavage-recombination mechanism. Tayama et al. suggested that the stability of the benzylic radicals involved and the solid-liquid biphasic reaction conditions employed determine the stereochemical course of the reaction (Scheme 1). The recombination of the radical pair initially formed from the *N*-ylide occurs more rapidly in a solvent cage and hence more preferentially in a retentive fashion



Scheme 1

The main drawback of this methodology is accessing the pure diastereomer of the ammonium salt, which requires stereoselective quaternization with methyl iodide followed by several recrystallizations and ultimately yielding the pure diastereomer in low yields.

Tayama has also observed that, when the rearrangement is performed in THF at -40°C using potassium *tert*-butoxide as a base, the Sommelet-Hauser rearrangement (concerted [2,3]sigmatropic process) proceeded exclusively to give the corresponding α -aryl proline derivative **3** in 96% yield and 99% enantiomeric excess (Scheme 2).⁷⁷

⁷⁷ Tayama, E.; Kimura, H. *Angew. Chem.Int. Ed.* 2007, 46, 8869-8871.

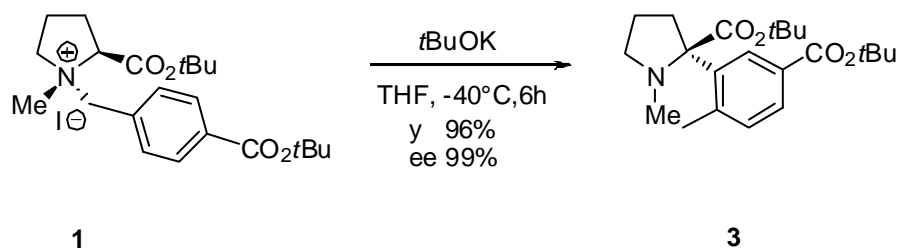

Scheme 2

Another example of Stevens rearrangement was described by Somfai.⁷⁸ He performed an asymmetric Lewis acid mediated [1,2]-shift of proline derivatives; he found that complexation of proline amide derivatives **4** with BBr_3 , followed by addition of Et_3N , gave the corresponding products **5** in good yield and excellent enantiomeric excess.



Table 3.

Entry	4	Ar	t (h)	5	(%)	ee (%)
1	4a	Ph	1	5a	85	96
2	4b	4- <i>t</i> Bu-Ph	1	5b	82	96
3	4c	4-Br-Ph	1	5c	76	96
4	4d	4-CF ₃ -Ph	1	5d	82	96
5	4e	2-Me-Ph	2	5e	81	96
6	4f	2-Tyophene	1	5f	79	96

The high enantiomeric excess can be explained by an *in situ* formation of the rigid bicyclic complex **6** (Scheme 3). Treatment of amide **4a** with BBr_3 results in coordination of the Lewis acid *cis* to the amide moiety, which is followed by formation of structure **6**. Subsequent deprotonation of **6** with Et_3N provides ylide **7**, which suffers a homolytic cleavage of the C-N bond (structure **8**) and then a radical recombination to form complex **9**. An efficient N-C chirality transfer is secured by selective migration of the benzyl radical on the Re-face.

⁷⁸ Pavel, T.; Somfai, P. *Org. Lett.* **2009**, 919-921.

Finally, hydrolysis of **9** gives **5a**, the absolute stereochemistry of which is identical to the starting material **4a**.

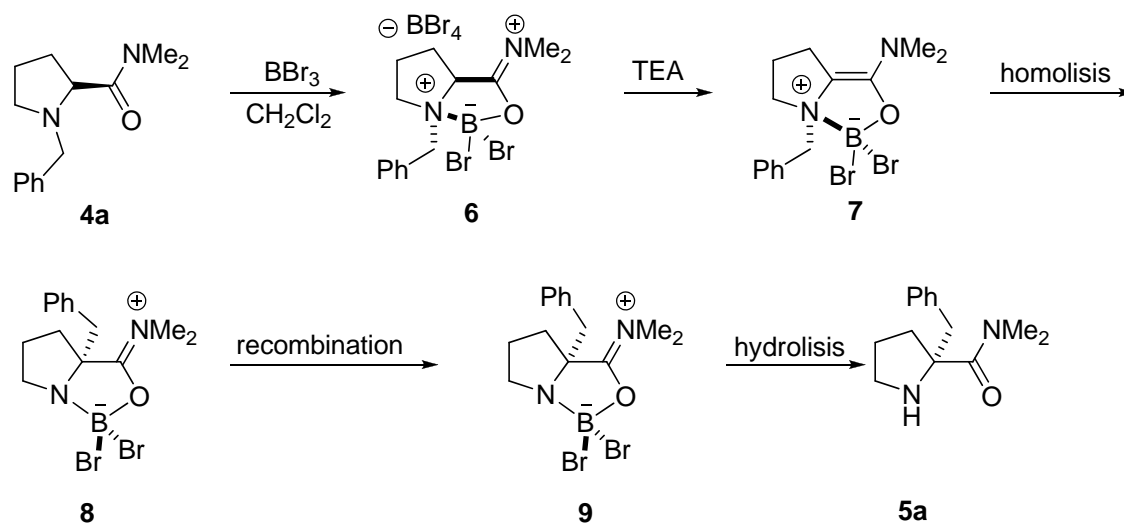

Scheme 3

An exclusive [2,3]-shifts of a prenyl group for substrate **10** has been reported by Coldham,⁷⁹ (Scheme 4). In this case, the rearrangement is stereospecific because the [2,3]-migration is restricted to the same face.

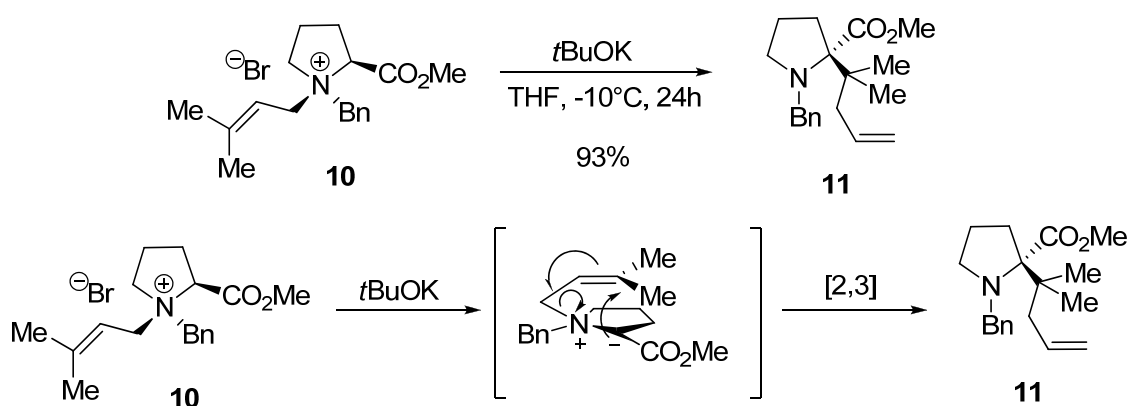

Scheme 4

Finally, the ester-enolate Claisen rearrangement is a powerful method for enantioselective C-C bond formation from an original chiral ester. Recently this type of reaction was applied to an α -acyloxy- α -vinylsilane possessing a proline as the acyloxy group (Scheme 5).⁸⁰ The enolate generated from **12** underwent the Claisen rearrangement, through a chair-like transition state with a *Z*-enolate in the presence of

⁷⁹ Arboré, A. P. A.; Cane-Honeysett, D. J.; Coldham, I.; Middleton, M. L. *Synlett* **2000**, 236–238

⁸⁰ Sakaguchi, K.; Yamamoto, M.; Watanabe, Y.; Ohfuné, Y. *Tetrahedron Lett.* **2007**, *48*, 4821–4824.

HMPA, to give the α -substituted proline derivative **13** with transfer of the original chirality of the ester counterpart.

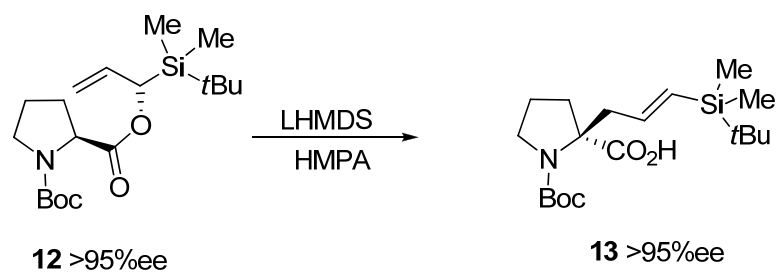

Scheme 5

5- Results

Wilson et al., with the aim to deprotect a series of optically pure N-alkyl-N-(nitrobenzenesulfon) amino acid tert-butyl esters, found that the reaction between the tertiary protected amino acid and the basic ion exchange resin (Amberlite 120) furnished a large amount of a by-product. As an example, in the reaction of valine derivative **1** (Scheme 1), the analysis of by-product **3** (¹H NMR and Mass spectral analyses) were consistent with the absence of sulfur dioxide.⁸¹

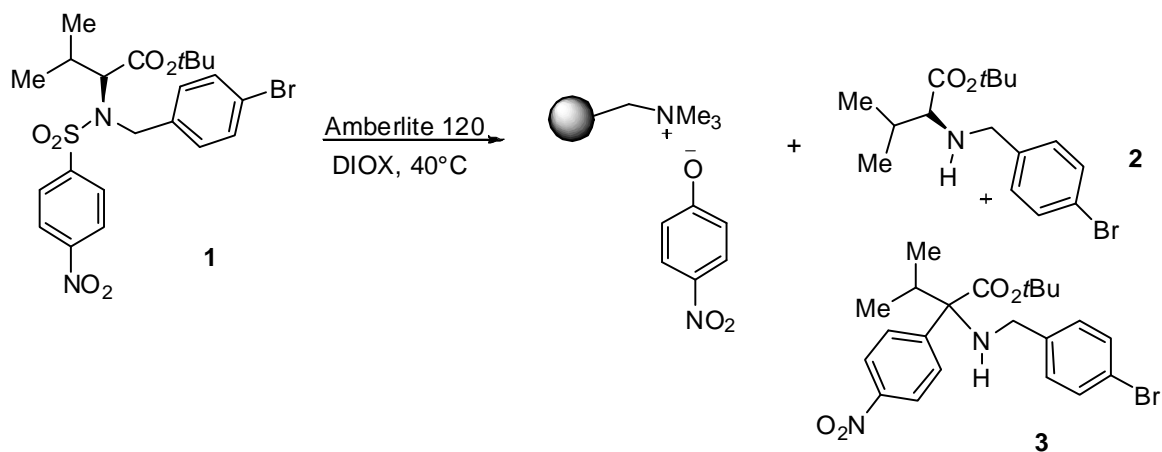

Scheme 1

The X-ray crystallographic analysis of the HCl salt of **3** confirmed both his structure and racemic nature. Further investigation revealed that quaternary amino ester **3** could be obtained as the main product as a racemic mixture, when 50% aqueous Bu₄N⁺OH- solution was used as a base (Scheme 2).

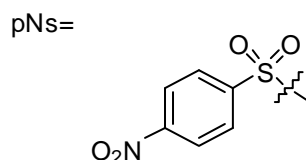
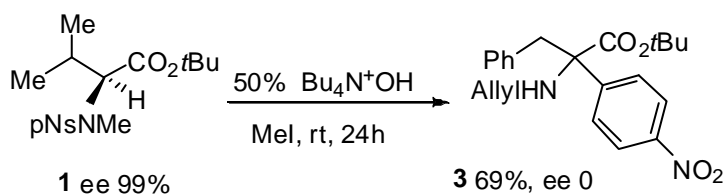

Scheme 2

⁸¹ M. W. Wilson, S. E. Ault-Justus, J. C. Hodges and J. R. Rubin, *Tetrahedron*, 1999, 55, 1647.

The migration of the 4-nitrophenyl moiety is due to the intramolecular nucleophilic attack of the enolate **4** toward the aromatic ring, which affords the Meisenheimer intermediate **5** (Figure 1).

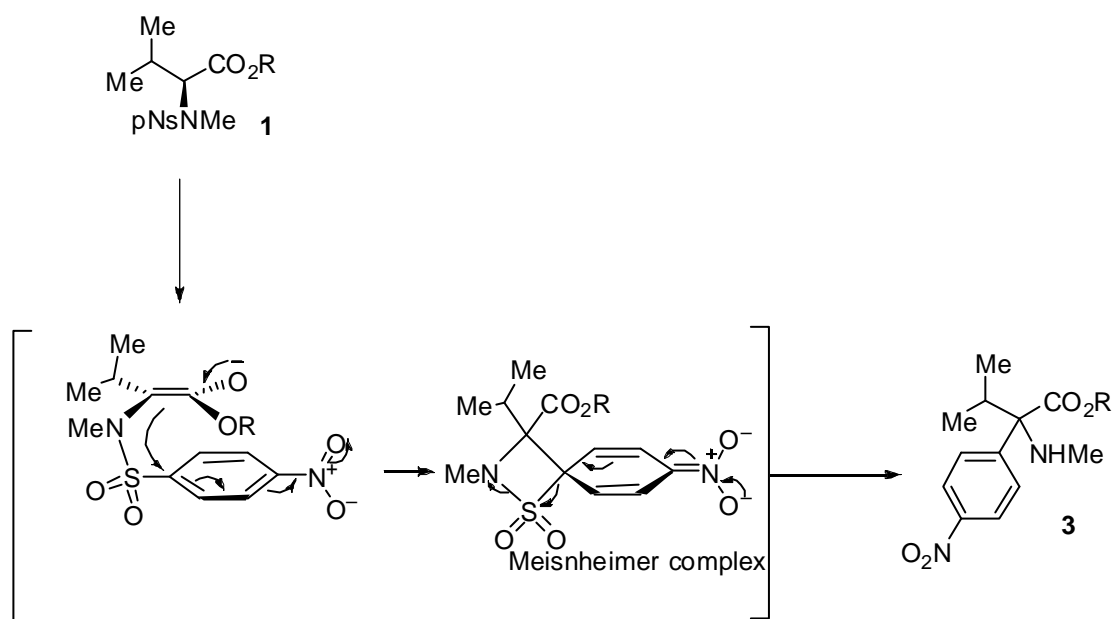

Figure 1

Subsequent S-C_α migration of the *p*-nitrophenyl group is promoted by loss of sulfur dioxide, whose gaseous nature acts as a strong driving force shifting the equilibrium toward the product **3**.

An analogous rearrangement has been reported for a 9-(*N*-4-nitrobenzenesulfonyl-*N*-methylamino) fluorene system⁸² and 2-cyano-(*N*-4-nitrobenzenesulfonyl)-acetamide.⁸³

A survey on chemical literature, which did not evidence any further attention to this degradative rearrangement as a practical synthetic method, stimulated our interest in investigating the applicability of this protocol to the enantioselective synthesis of quaternary α-aryl-α-amino acids.

⁸² Meng, Q.; Thibblin, A. J. *Am. Chem. Soc.* 1997, 119, 1224-1229.

⁸³ Naito, T.; Dohmori, R.; Nagase, O. *J. Pharm. Soc. Japan.* 1954, 74, 593-595.

5.1

To establish the best rearrangement conditions, we choose as model compound the proline derivative **4a**, which has been prepared by condensation of 4-nitrobenzenesulfonyl chloride and proline *tert*-butyl ester hydrochloride.

The reaction, conducted at 0-25°C, in dichloromethane with di-(*iso*-propyl)ethylamine (DIEA) as a base, gave the desired product **4a** in good yield (Scheme 3).

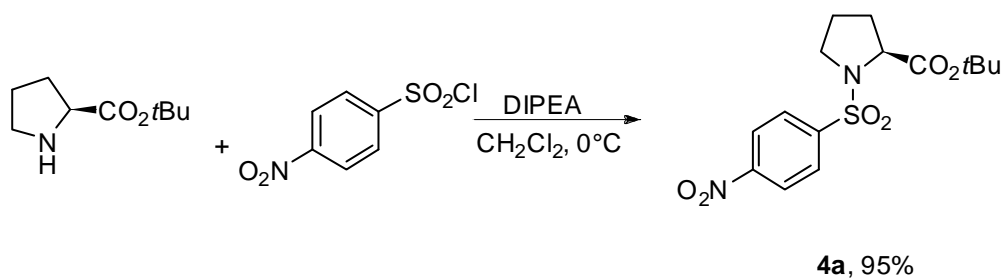

Scheme 3

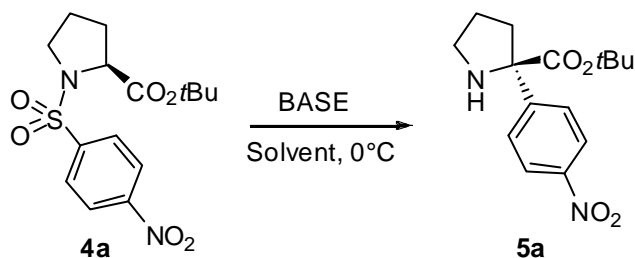
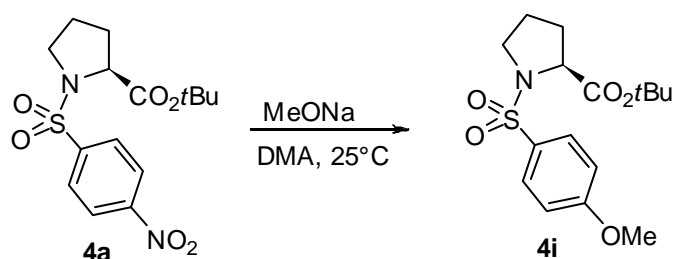

Table 7.1 Rearrangement of Proline Derivative **4a**

Entry	Base	Solvent	t (h)	2a (%)	<i>ee</i> (%)
1	NaNH ₂	DMA	0.25	90	94
2	NaNH ₂	DMA	1.5	89	96
3	NaNH ₂	DMF	1	68	94
4	NaNH ₂	NMP	24	-	-
5	NaNH ₂	DMSO	24	-	-
6	LiNH ₂	DMA	24	-	-
7	LDA	DMA	0.25	-	-
8	LDA	THF	24	-	-
9	LDA	DMF	96	40	77
10	<i>t</i> BuOK	DMA	48	15	92
11	DBU	DMA	48	-	-
12	MeONa	DMA	48	-	-
13	NaH	DMA	26	79	94
14	NaH/NH ₃	DMA	1	97	94

Preliminary runs (Table 1), conducted on compound **4a** by changing both base and solvent, evidenced that the best yield and enantiomeric excess of the quaternary proline ester **5a** could be reached by using a strong, non-hindered base like NaNH₂, operating at 0°C (Table 1, Entry 1) in DMA as the solvent. Longer reaction times were necessary by operating at -20°C (Entry 2). The use of DMF instead of DMA (Entry 3) resulted in lower yields of **4a**, while other 'non-hydrogen bonding donor' solvents (Entries 4-5) were ineffective.

Very poor or no results were obtained with the more sterically demanding *tert*-BuOK, DBU and LDA (Entries 6-11). Furthermore, the use of sodium methoxide (Entry 12) promoted the NO₂-MeO nucleophilic aromatic substitution on the starting sulfonamide **4a** and *N*-(4-methoxybenzenesulfonyl)proline *tert*-butyl ester (**4i**) was the sole product (Scheme 4). The compound **4i**, in turn, was stable under strong basic conditions and the related quaternary derivative **5i** was not formed, even in traces.



Scheme 4

Interestingly, using NaH as a base (Entry 13), compound **4a** was obtained with comparable yield to that obtained by using sodium amide but the reaction time was much longer.

Probably, by using sodium amide, the ammonia produced in the process, solvates the sodium ion associated to the carbanion derived from **4a**, forming a 'loose ion-pair' that is much more reactive than the unsolvated 'tight ion-pair' generated by deprotonation with sodium hydride (Scheme 5).

A run conducted by generating the anion with NaH and then saturating the reaction mixture with anhydrous ammonia gas confirmed this hypothesis: the target product **2a** was isolated with similar yield, enantiomeric excess and reaction time to that obtained by using sodium amide (Entry 14).

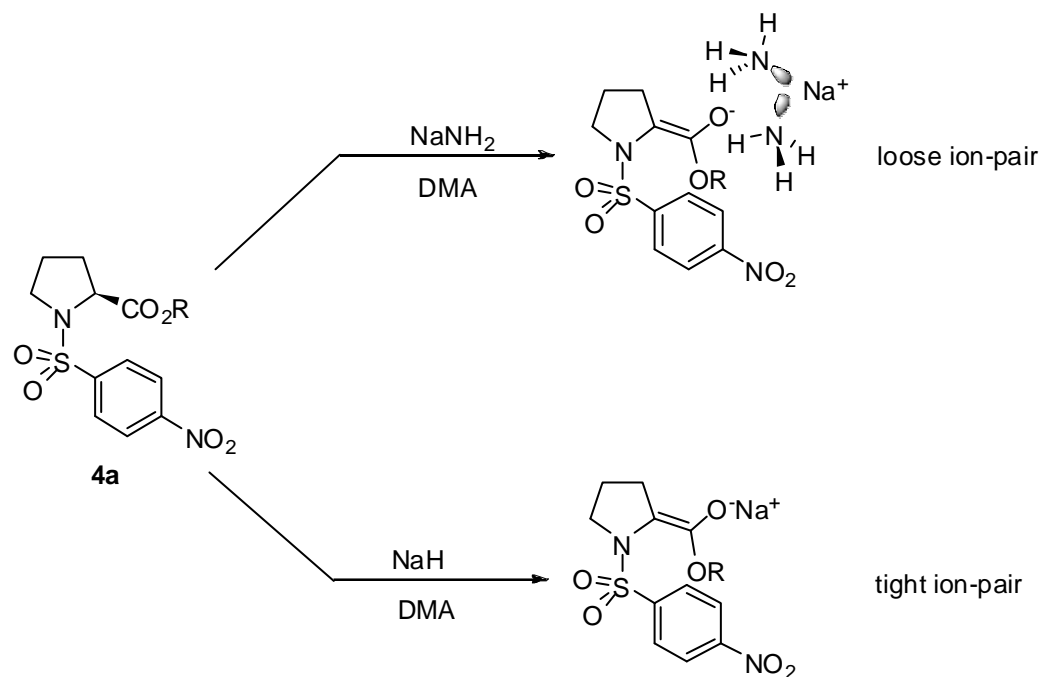

Scheme 5

To establish the stereochemical course of the rearrangement process, **5a** was transformed into the carboxylic acid hydrochloride **R-6** (Scheme 6).

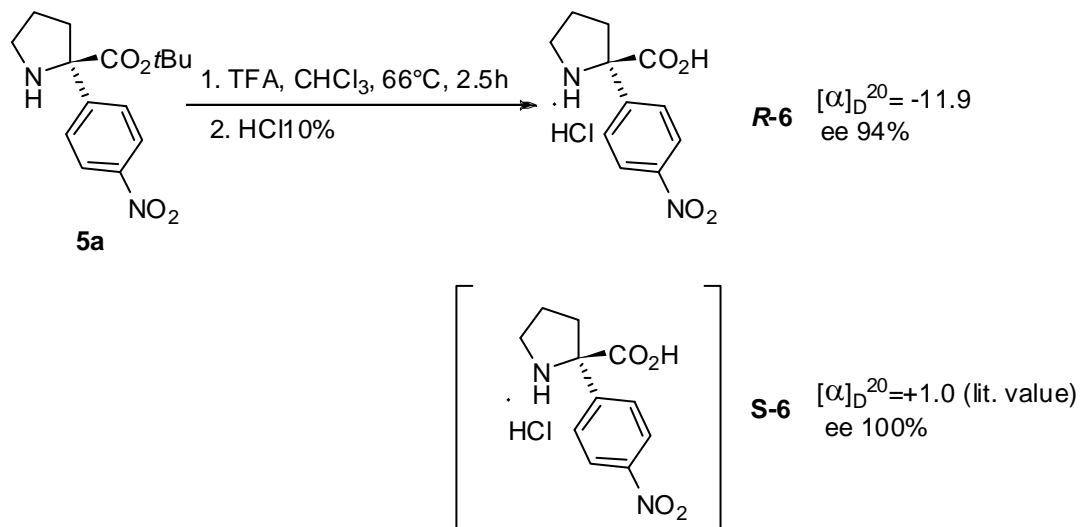

Scheme 6

The comparison of its optical rotatory value with that of the literature enantiomer **S-6**⁸⁴ (the unique quaternary proline derivative of this type known) showed that the 4-

⁸⁴ M. Mąkosza, D. Sulikowski, O. Maltsev, *Synlett* 2008, 1711-1713.

nitrophenyl group preferentially rearranges to give the retention product. Since the absolute $[\alpha]_D$ value of **R-6** and **S-6** was too much different, we decided to assign the right configuration of compound **5a** by X-ray analysis.

We tried to synthesize different crystalline derivatives bearing at the least one heavy atom and, several unsuccessful attempts were made to crystallize the product for X-ray confirmation. Neither the hydrochloride salt **R-6** nor the hydro iodide correspondent were suitable solids for X-ray crystallographic analysis. We tried to convert the amino function of **5a** but, this moiety was not reactive with any sulfonyl chloride in presence of DIEA(Scheme 7).

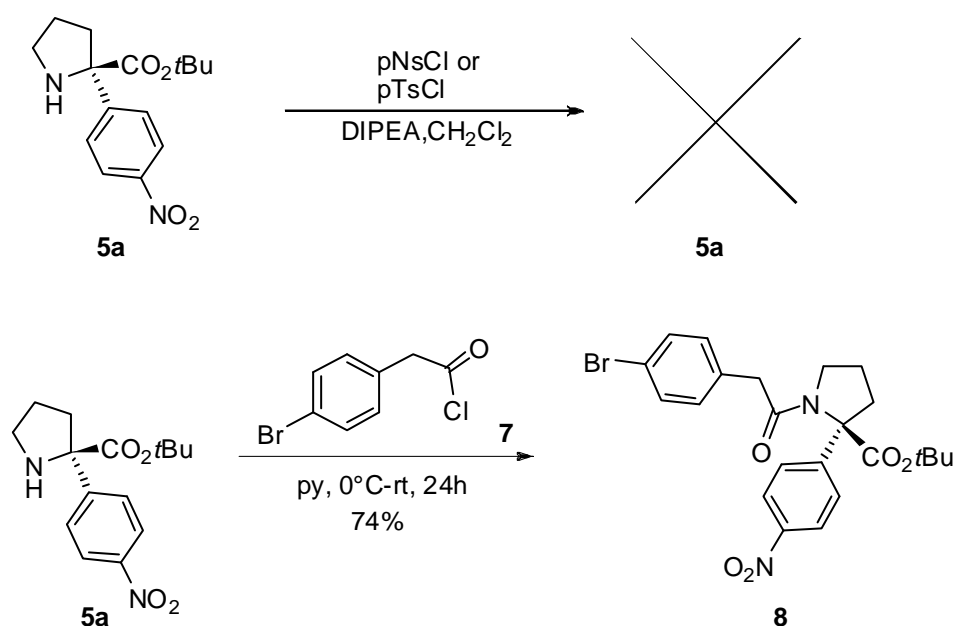

Scheme 7

On the other hand, the NH group reacted with the acyl derivative **7** in presence of pyridine, under homogenous conditions. After recrystallization, the X-ray analysis of **8** confirmed the formation of the retention product (Figure 2).

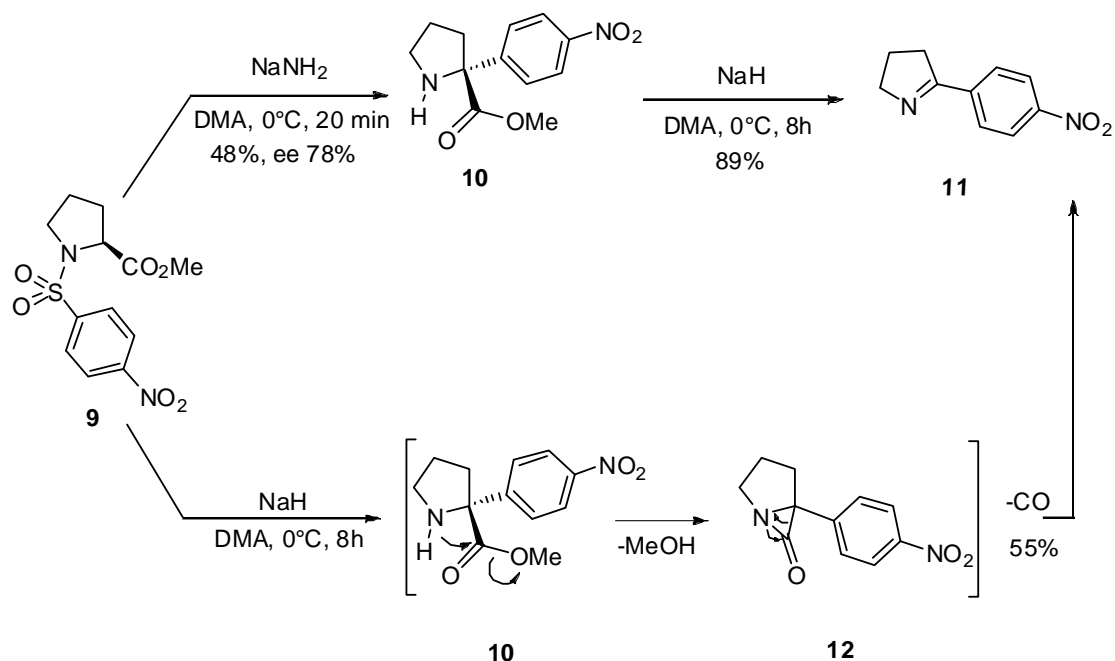

Scheme 9

In the way of both generalizing this enantioselective process and better understand the reaction mechanism, we have applied the best reaction conditions found for **4a** to a series of substituted arylsulfonamido proline esters **4b-j** (Table 2).

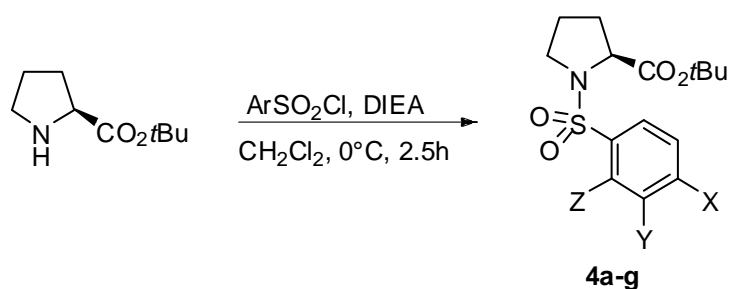

Table 2. Synthesis of proline sulfonamides **4**

Entry		X	Y	Z	4 (%)
1	a	NO_2	H	H	95
2	b	NO_2	CF_3	H	98
4	c	NO_2	H	OMe	87
6	d	CN	H	H	90
9	e	H	H	NO_2	85
10	f	$\text{CON}(\text{CH}_2)_4$	H	H	89
11	g	NO_2	H	NO_2	93
12	h	Me	H	H	97
13	i	MeO	H	H	99
14	j	H	NO_2	H	89

In particular, we synthesized the arylsulfonyl derivatives, bearing on the phenyl ring the functional groups 4-nitro-3-trifluoromethyl (**4b**), 4-nitro-2-methoxy (**4c**), *para*-cyano (**4d**), *ortho*-nitro (**4e**), *para*-pyrrolidine carboxamide (**4f**) and 2,4-di-nitro (**4g**), and *meta*-nitro (**4h**), *para*-methyl (**4i**), *para*-methoxy (**4j**) groups

In presence of either sodium amide or sodium hydride, in DMA as solvent at 0°C, we isolated the transposition derivatives **5a-e** (Table 3):

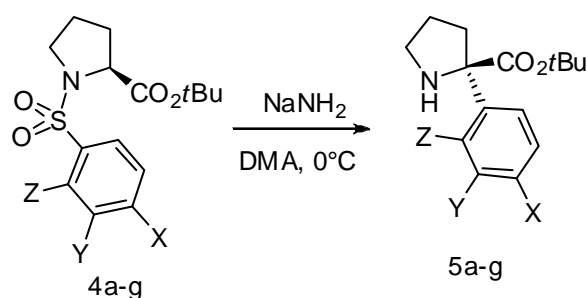

Table 3. Rearrangement of Proline Derivative **4a-j**

Entry	Sulfonamide					Product			
		X	Y	Z	t (h)	Yield (%)	<i>ee</i> (%)		
1	a	NaNH ₂	NO ₂	H	H	0.25	5a	90	94
2	b	NaNH ₂	NO ₂	CF ₃	H	0.33	5b	64	94
3	b	NaH	NO ₂	CF ₃	H	48	5b	-	-
4	c	NaNH ₂	NO ₂	H	OMe	0.5	5c	50	93
5	c	NaH	NO ₂	H	OMe	24	5c	64	93
6	d	NaNH ₂	CN	H	H	0.33	5d	61	96
7	d	NaH	CN	H	H	48	5d	44	96
8	e	NaNH ₂	H	H	NO ₂	0.33	5e	54	94
9	e	NaH	H	H	NO ₂	48	5e	-	-
10	f	NaNH ₂	CON(CH ₂) ₄	H	H	24	5k	-	-
11	g	NaNH ₂	NO ₂	H	NO ₂	0.5	5g	-	-
12	h	NaNH ₂	Me	H	H	24	5h	-	-
13	i	NaNH ₂	MeO	H	H	24	5i	-	-
14	j	NaNH ₂	H	NO ₂	H	48	5f	-	-

The presence on the aromatic ring of an electron-withdrawing group (EWG), which must be able to stabilize an intermediate Meisenheimer complex, is essential for the reaction progress. For that reason, compounds **4a-e**, bearing *ortho*- and *para*-nitro or *para*-cyano groups, gave good results while the presence of substituents in the *ortho*- or *meta*-position on the aromatic ring (Entries 2, 4 and 8), increasing the steric hindrance, was detrimental to the overall process and reaction yields dramatically decreased. The *N*-(2,4-dinitrobenzenesulfonyl)proline *tert*-butyl ester **4g**, reacted rapidly, but gave only a series of by-products (Entry 11).

On the contrary, the pyrrolidine carboxamide **4f** (Entry 10) was unreactive, due to the low EWG ability of the carbonyl group.

Compounds containing in the arylsulfonyl moiety *meta*-nitro (Entry 14) or electron-donating groups, such as methyl or methoxy (Entries 12 and 13), were unreactive at 0°C. To test the reactivity of these sulfonamides, compound **4h** was reacted at higher temperature, but we observed the degradation of the starting material and, by quenching the reaction mixture with methyl iodide, we isolated sulfone **13a** and pyrroline **13b** (Scheme 10). Sulfone **13a** derived probably from the formation of an instable sulfinyl derivative

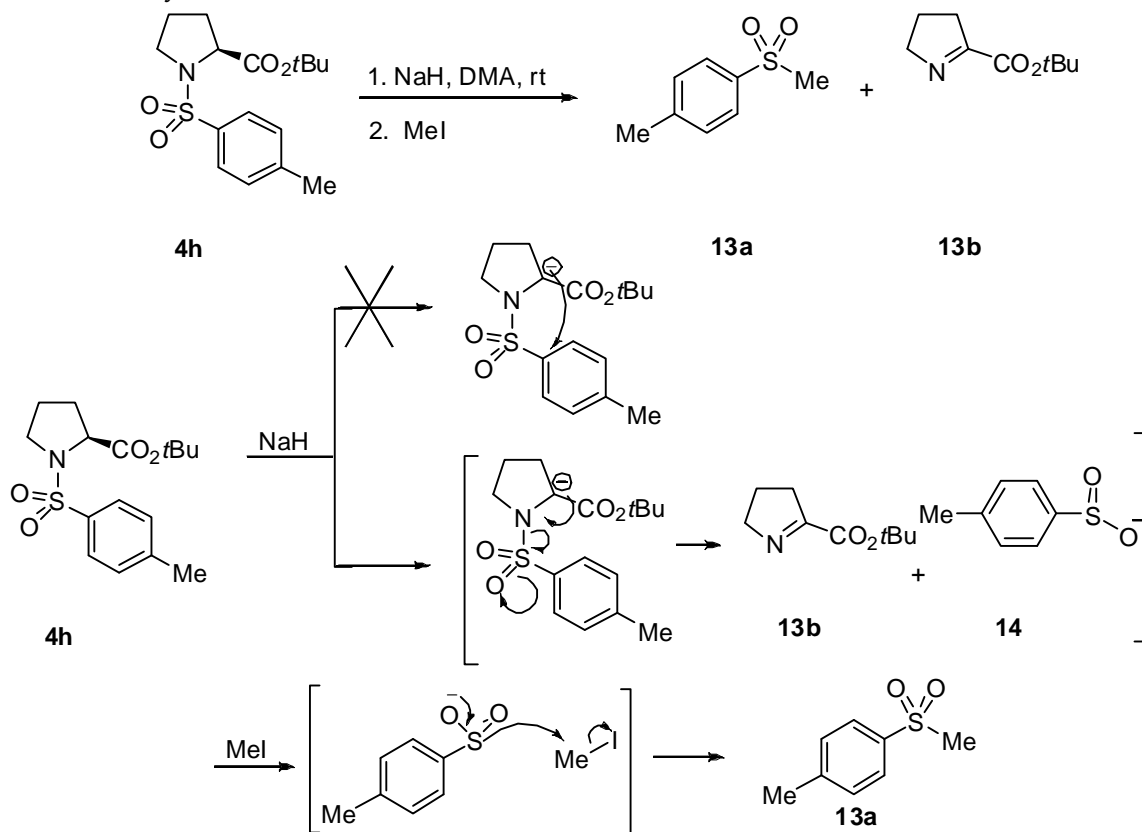

Scheme 10

All these results indicate that the formation of a spiro-Meisenheimer complex (Scheme 11) should be the key step of the degradative rearrangement. Deprotonation of the less crowded conformer of the substrate **4a**, in which the arylsulfonyl group is far from the *tert*-butyl ester, gives the non-racemic enolate **A**. This intermediate, through a *Re*-face attack, evolves into a chiral spiro-Meisenheimer complex **B** that, in turn, undergoes the *S*-C $_{\alpha}$ migration of the aryl group, with an overall configuration retention.

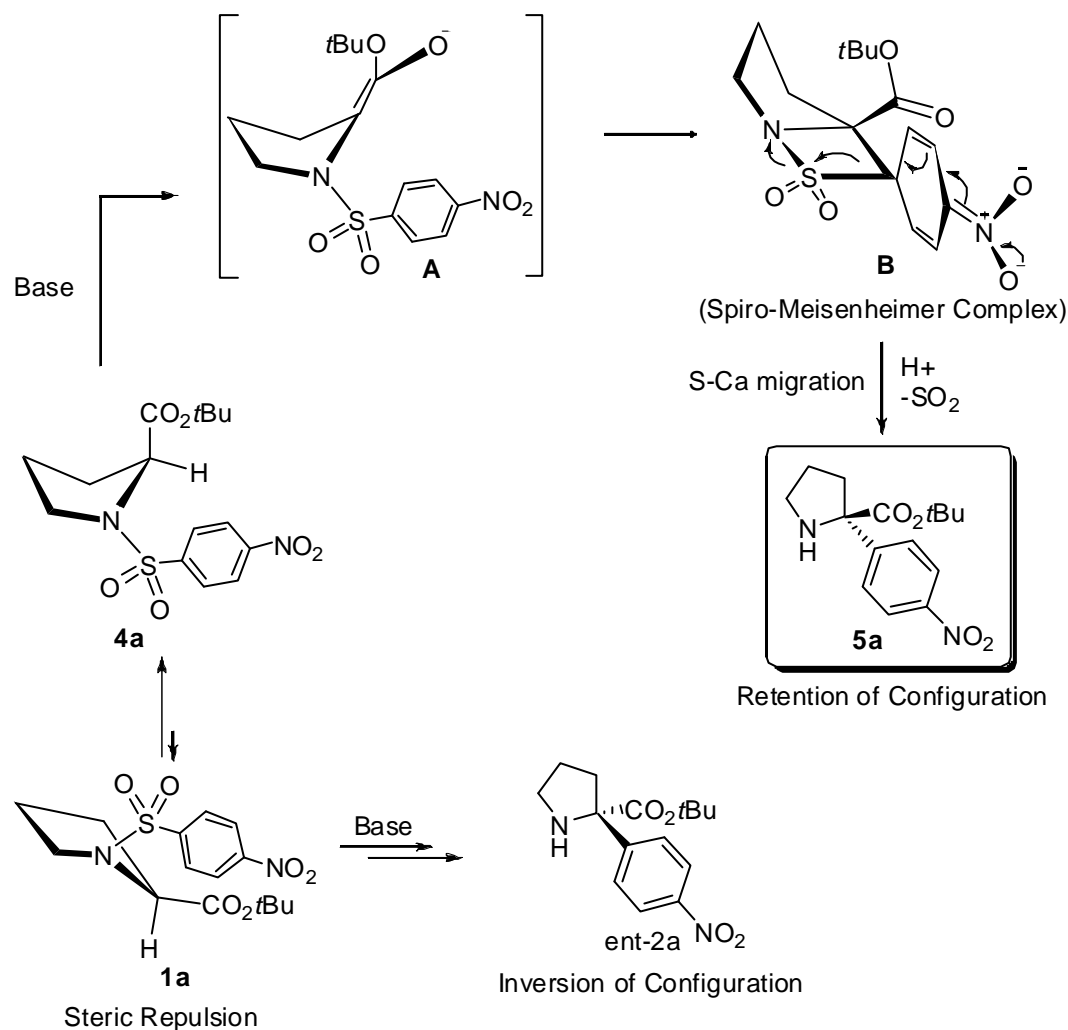

Scheme 11

5.2

After having defined the optimal conditions for the transposition of proline derivatives, we investigate the synthesis of acyclic α -alkyl- α -aryl-glycine derivatives.

Differently from cyclic sulfonamides, open chain derivatives did not react under the action of several basic system, and in each cases compound **15** was recovered unchanged; in fact, the reaction proceeds only with the addition of an alkylating agent (Scheme 12).

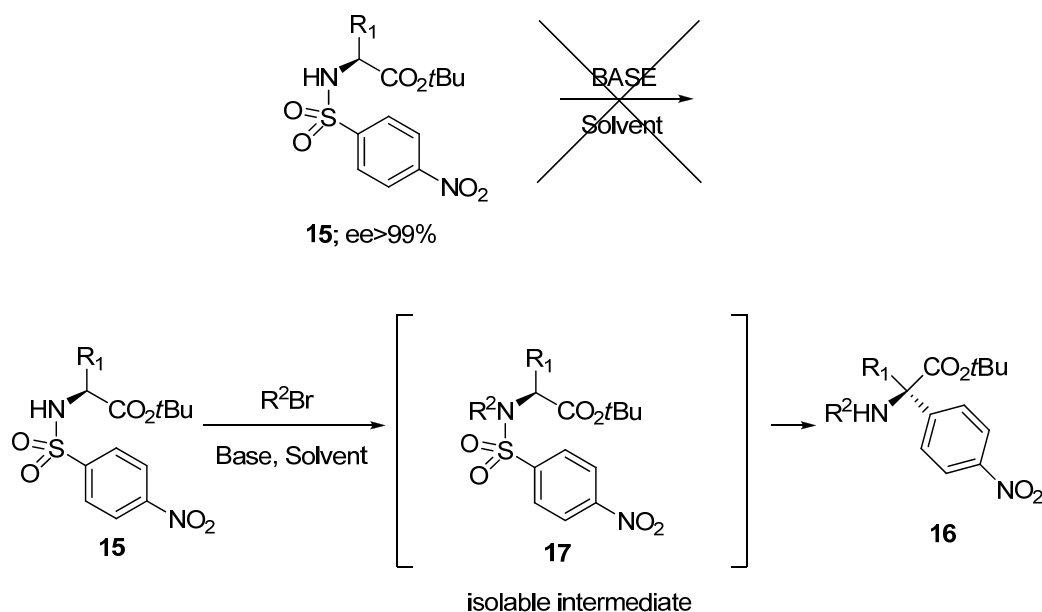

Scheme 12

To establish the best alkylation/rearrangement conditions, L-tert-butyl N-(p-nosyl)-phenylalaninate **15a** was reacted with allyl bromide as alkylating agent (Table 4). The best yields and enantiomeric excess of **16a** were reached by using NaH as a base, operating in dimethylacetamide (DMA) or in DMF at 0°C (Table 4, entry 1-3). Other 'non-hydrogen bonding donor' solvents (Entries 4,5), gave poor results. The unrearranged optically pure N-allyl amido ester **17a** was the sole product isolated under solid-liquid PTC conditions (Entries 6,7) or by using *n*-BuLi in THF at low temperatures (Entries 9,10). Using sodium amide (Entry 5) we isolated only a series of by-products and compound **17a** was not detected even in traces.

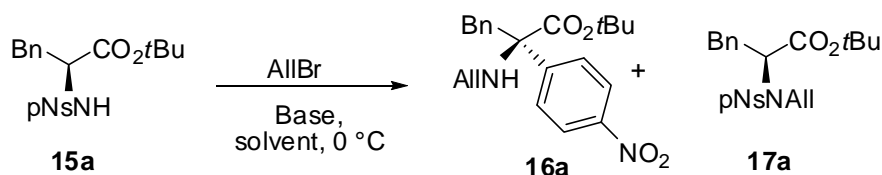

Table 4. Allylation/rearrangement of sulfonamido *t*-butyl ester **15a**

Entry	Base	Solvent	t [h]	16a (%)	<i>ee</i> (%)	17a (%)
1	NaH	DMA	5	97	62	–
2	NaH	DMF	6	78	75	–
3	NaH	DMSO	72	71	48	–
4	NaH	DMPU	5	15	20	–
5	NaNH ₂	DMA	24	–	–	–
6	K ₂ CO ₃	DMSO	2.5	–	–	87
7	K ₂ CO ₃	DMSO	2.5	–	–	95
8	NaOH/K ₂ CO ₃	DMSO	5	–	–	–
9	<i>n</i> -BuLi	THF	24	–	–	–
10	<i>n</i> -BuLi	THF	24	–	–	–

The phenylalanine derivative **15a** was then rearranged in the presence of a series of alkyl halides R²X, under the action of sodium hydride in DMA (Table 5). The corresponding *N*-alkylated α -quaternary esters **16a-h** were obtained in good yields, with enantiomeric excess in the range 51-82%. In particular, the *N*-methyl (**16b**) and *N*-propargyl (**16h**) derivatives were isolated with the best yields and enantioselectivities (Entries 2,8), whereas 1-iodooctane and benzyl bromide gave large amounts of intermediated unrearranged *N*-alkyl *p*-nosylamido esters **17f,g**. To prove the influence of the reaction temperature, **15a** was then reacted at -20°C with the more activated alkylating agents, but the observed effect was a longer reaction time, with modest enantiomeric excess increments, in a range of 9-12 (Entries 1,2,7).

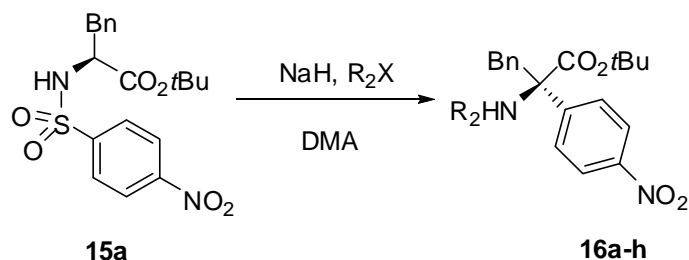
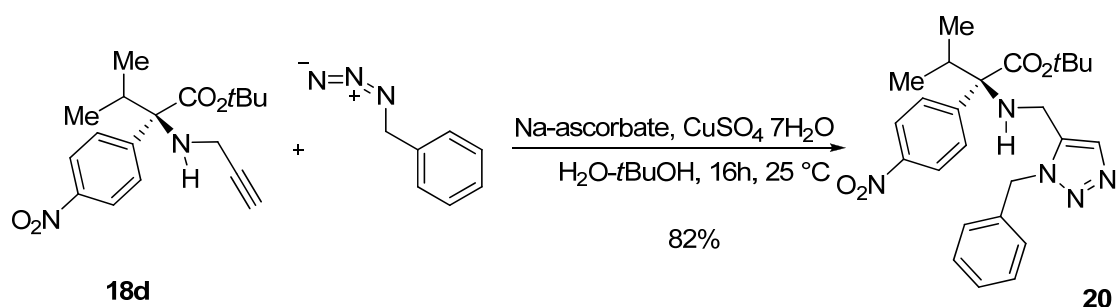

Table 5. Rearrangement of sulfonamido *t*-butyl ester **15a** with several alkylating agents R²X

Entry	R ² X	At 0°C			At -20°C		
		t (h)	Yield (%)	<i>ee</i> (%)	t(h)	Yield(%)	<i>ee</i> (%)
1	a AllBr	5	16a 87	62	48	16a 85	74
2	b MeI	2	16b 96	82	24	16b 90	91
3	c EtI	7	16c 99	57	-	-	-
4	d <i>n</i> PrI	16	16d 80	57	-	-	-
5	e <i>n</i> BuI	4	16e 86	62	-	-	-
6	f C ₈ H ₁₇ I	16	16f 73	61	-	-	-
7	g BnBr	4	16g 75	51	48	16g 84	61
8	h PrgBr	8	16h 88	80	-	-	-

Allyl and propargyl bromide were used as alkylating agents to study the reactivity of several representative α -(*p*-nosylamido)acid *tert*-butyl esters (Table 6). We choose allyl bromide since the allylic function can be easily and selectively removed; propargyl bromide because the propargylic moiety is a useful syntone, for example in click reactions (Scheme 13).



Scheme 13

Nearly quantitative yields and very high enantiomeric excess of the corresponding rearranged products ($\geq 95\%$) were reached with strongly hindered valine **15d** and isoleucine **15e** derivatives, using both allyl and propargyl bromide (Entries 4,5,8,9).

The phenylglycine derivative **15b**, which is very sensitive to basic conditions, reacted with poor enantioselectivity (Entry 2).

Finally, operating at -20°C the alanine derivatives **18c**, **19c** and the phenylglycine derivative **18b** were obtained with fairly good enantioselectivities.

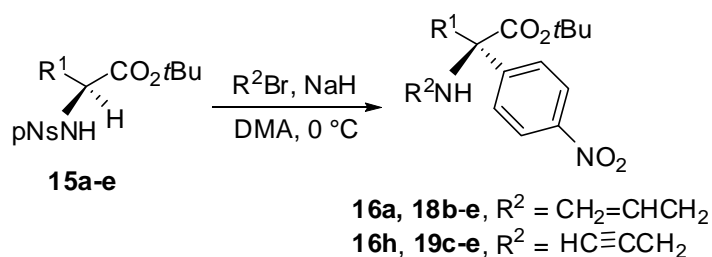

Table 6. Alkylation/rearrangement of *t*-butyl esters **15a-e** with allyl and propargyl bromide

Entry	Substrate		N-Allyl Derivative					
			At 0°C			At -20°C		
			t (h)	Yield (%)	<i>ee</i> (%)	t (h)	Yield (%)	<i>ee</i> (%)
1	15a	PhCH ₂	5	16a 87	62	48	16a 85	74
2	15b	Ph	28	18b 92	50	48	18b 65 ^b	58
3	15c	Me	6	18c 89	59	16	18c 89	68
4	15d	<i>i</i> Pr	24	18d 99	95	-	-	-
5	15e	<i>s</i> Bu	26	18e 99	96	-	-	-

		N-Propargyl Derivative ^c			
		t (h)	Yield (%)	<i>ee</i> (%)	
6	15a	PhCH ₂	8	16h 88	80
7	15c	Me	5	19c 93	68
8	15d	<i>i</i> Pr	20	19d 98	96
9	15e	<i>s</i> Bu	26	19e 97	98

As the same as we have just described above for cyclic proline derivatives, we applied the alkylation/rearrangement conditions to other sulfonamides (synthesized under homogenous conditions) capable of stabilizing the Meisenheimer intermediate.

The stereochemical outcome of the aryl migration of the open chain amino acids was determined by transforming the α -quaternary alanine derivative **18c** into the corresponding (*R*)-2-amino-2-(4-nitrophenyl)-propionic acid **R-24**. After deprotection of the *N*-allylic function; the comparison with its (*S*)-enantiomer, the sole known α -(4-nitrophenyl)- α -amino acid,⁸⁵ showed that the 4-nitrophenyl group preferentially rearranges to give the retention product.

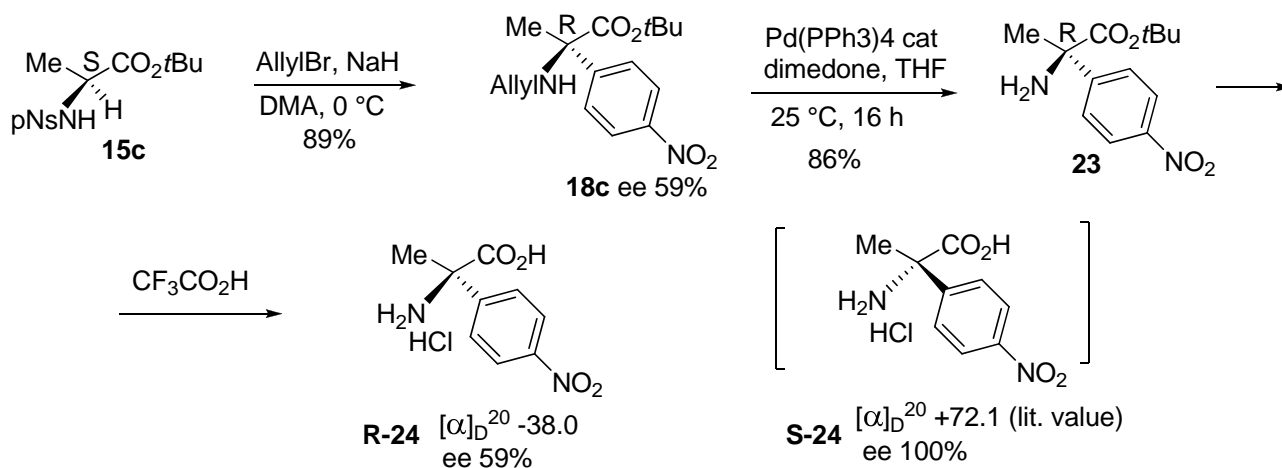

Scheme 15

A series of experiments have been conducted to evaluate the chiral properties of the intermediate enolate and to clarify the mechanism of this asymmetric induction. The use of methyl ester **25** instead of the *tert*-butyl ester **15a**, gave the rearranged methyl *N*-allyl- α -(4-nitrophenyl)-phenylalaninate **26** in 80% yield, but with an enantiomeric excess of only 19%; therefore, the use of *tert*-butyl esters as protection of the carboxylic moiety is essential for the enantioselectivity of this process (Scheme 16).

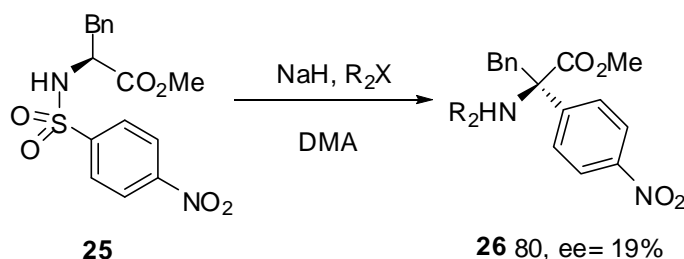

Scheme 16

As above described, the non-alkylated sulfonamido ester **1a** did not react under

⁸⁵ (a) F. A. Davis, S. Lee, H. Zhang and D. L. Fanelli, *J. Org. Chem.*, 2000, **65**, 8704; (b) L. Ferron, F. Guillen, S. Coste, G. Coquerel and J.-C. Plaquevent, *Chirality*, 2006, **18**, 662.

degradative conditions in the absence of the alkylating agent and was recovered with unchanged enantiopurity (Scheme 17).

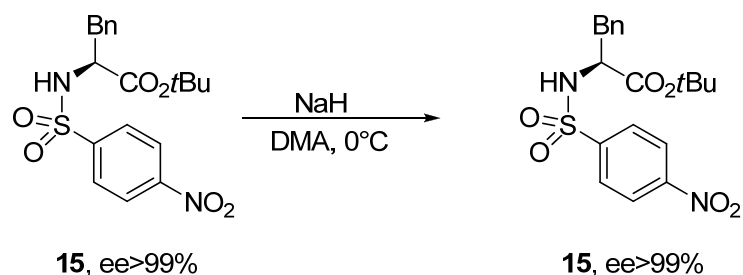

Scheme 17

The optically pure **17a**, prepared by Solid Liquid -Phase Tranfert Condition (SL-PTC) alkylation of **15**, reacted under trasposition conditions with good yield and higher reaction rate than the N-H derivative **15a**. Unexpectedly, the product **16a** showed a very low enantiomeric excess (28%, Scheme 18).

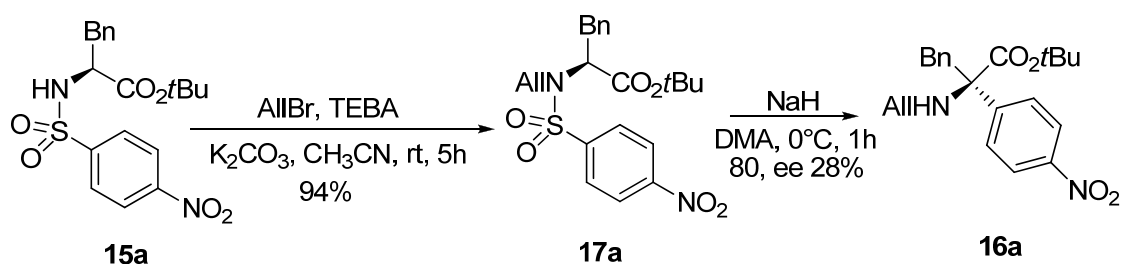

Scheme 18

On the contrary, reaction of the enantiopure *N*-allyl derivative **17a** (Scheme 19) in the presence of stocheiometric amounts of either non racemic (path **A**) or racemic (path **B**) unreactive N-H derivative **15a**, gave in each case product **16a** with the same enantiomeric excess to that obtained in the 'one pot' alkylation/rearrangement process.

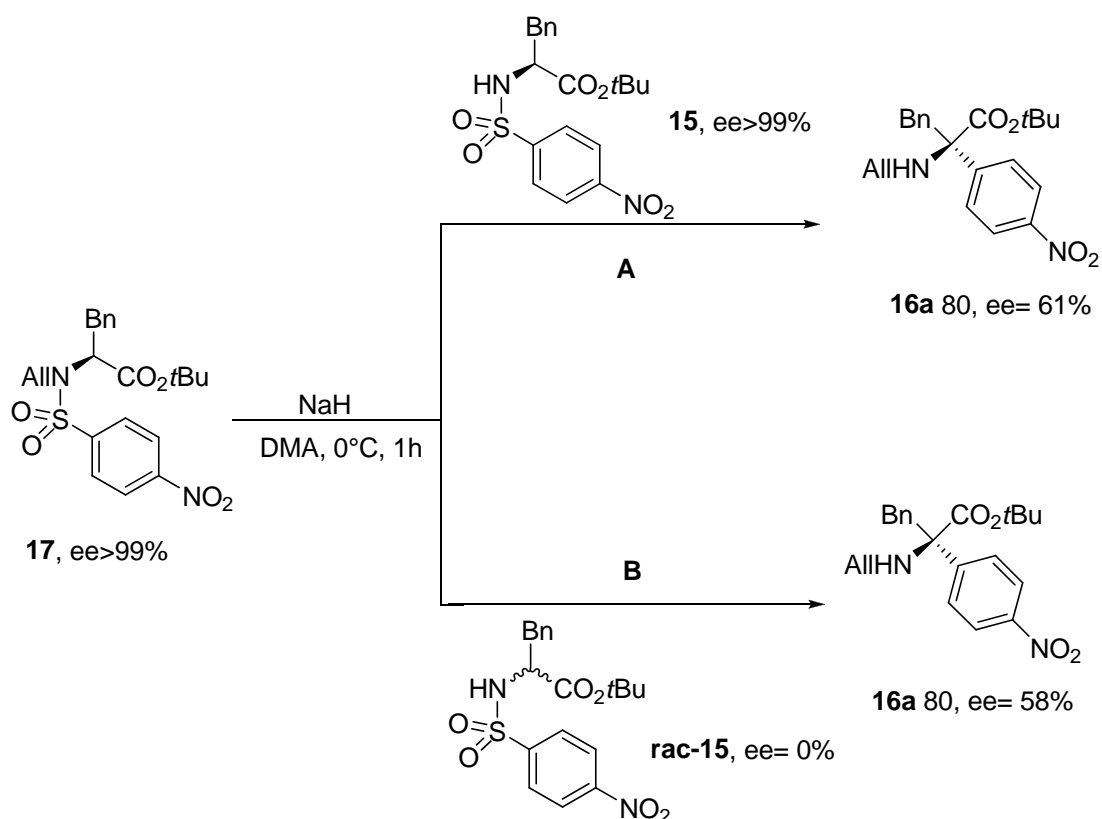

Scheme 19

Finally, racemic *N*-allyl derivative **rac-17a**, in the presence of optically pure N-H **15** (Scheme 20), gave racemic transposition product **rac-16a**.

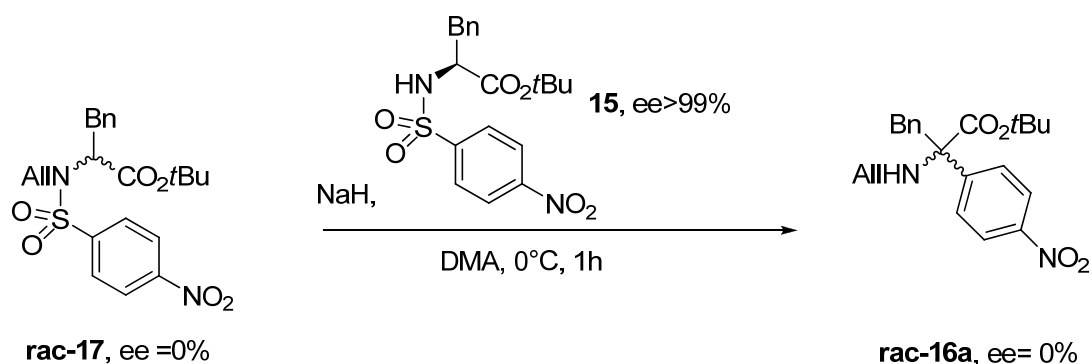

Scheme 20

These results, on the whole, indicate that the stereochemical information is transferred from the *N*-alkylated sulfonamide **17** to the final rearranged product **16** via a non-racemic enolate **B** (Scheme 20). This intermediate, through a *Re*-face attack, evolves into a chiral spiro-Meisenheimer complex that, in turn, undergoes the stereoselective $S\text{-C}_\alpha$ migration of the aryl group. The enolate **B** is likely formed by deprotonation of the less

crowded conformer **A**, in which the arylsulfonyl group is far from the *tert*-butyl ester. In the one-pot alkylation/rearrangement process, the aza-anion derived from **15a** probably stabilizes the enolate conformer **B**, elongates its racemization half-life, and then enriches the population of the favoured enantiomer (Scheme 21).

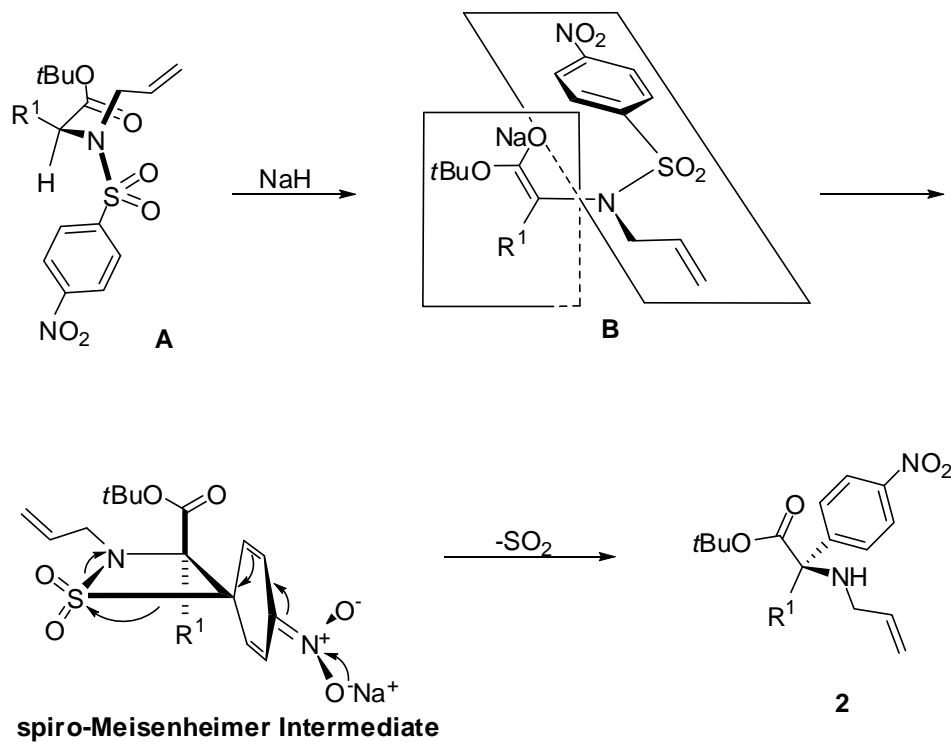

Scheme 21

5.3

Even though we performed a straightforward protocols for the enantioselectivities synthesis of α -quaternary aryl glycine derivatives - which are difficult to obtain through other synthetic way - this methodology cannot be used in the presence of amino acids bearing functional groups that could react under strong basic conditions (i.e. threonine, serine, tyrosine). In addition, the enolate, which is enantiomerically enriched, is not in its enantiopure form when uncrowded amino acids are used.

In order to generate a reactive intermediate (enol/enolate) in which the rotation along the C-N bond was minimum, we have chosen the *N*-allyl phenylalaninate **17a** as model compound for an extensive study devoted to find the optimal reaction conditions able to stabilize a chiral non racemic species.

We reacted compound **17a** in the presence of several basic systems (Table 8). A support for our hypotheses was obtained from the reaction, in the presence of a strong organic base likes DBU (Diazabicycloundecene), under homogenous and very mild conditions. Using DMA as solvent, the target compound **16a** was obtained in 95% enantiomeric excess at 25°C (Table 8, entry 2). Also in these cases the retention product was the major enantiomer isolated.

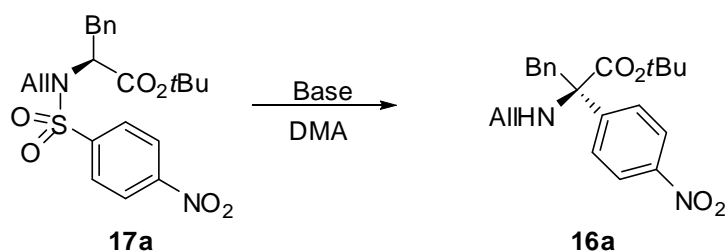

Table 8. Rearrangement of *N*-allyl phenylalanine **17a** with different bases

Entry	Base	T (°C)	t (h)	16 (%)	<i>ee</i> (%)
1	NaH	0	1	90	28
2	NaNH ₂	0	0.5	78	35
3	DBU	25	14	89	95
4	TMG	25	-	-	-
5	<i>t</i> BuTMG	25	-	-	-

Using DBU as standard base, we conducted several experiments varying the nature of the solvent (Table 9): in each reaction we isolated compound **16a** with good yields, and the

best enantiomeric excess was obtained using dimethoxy ethane (DME) or DMA (Table 9, Entry 1-3). Eventually, our choice fell on DME, because of its higher vapour pressure thus easier removal.

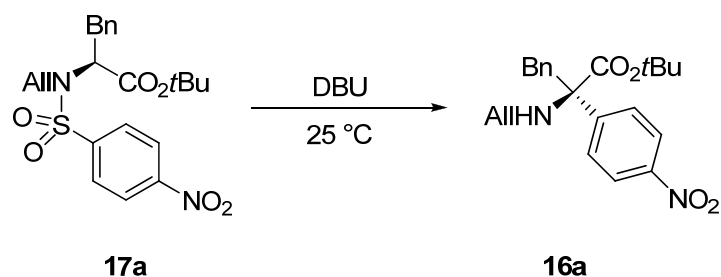

Table 9 Rearrangement of *N*-allyl phenylalanine **17a** with different solvents

Entry	Solvente	T (°C)	t (h)	yield (%)	ee (%)
1	DMA	25	14	89	95
2	DME	25	12	94	95
3	DME/ DMA	25	10	94	94
4	THF	25	12	88	83
5	CH ₂ Cl ₂	25	12	85	81
6	CH ₃ CN				

On these basis, DBU and DME were used as base and solvent to study the reactivity of a representative number of α - (*p*-nosylamido)acid *tert*-butyl esters **17** (Table 10).

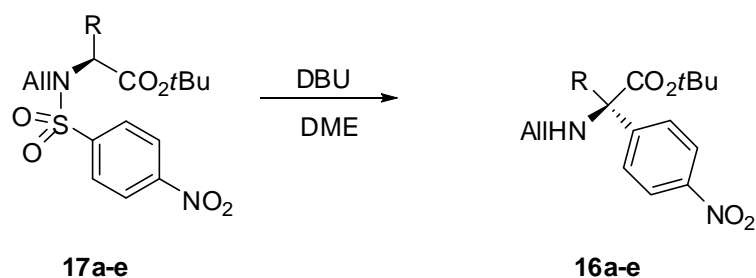

Table 10 Rearrangement of other *N*-allyl α -amino-acids **17a-e**

Enrty	R	T (°C)	t (h)	(%)	ee (%)
1	Phe	0	36	85	95
2	Phe	25	36	94	91
3	Ala	0	20	92	43
4	Leu	25	60	25	96
5	Val	25	60	30	95

While a low enantiomeric excess was detected using alanine (Table 10, entry 3), very poor yields were obtained with strongly hindered valine and isoleucine derivatives (entries 4,5). The obtained data indicates a strong reactivity dependence on the increasing dimension of the side chain on the amino acid. Thus, the smaller the steric hindrance near the reacting centre, the greater the reaction reactivity.

Thus, we decreased the steric hindrance on the ester function; phenylalanine methyl ester **28a** was treated with DBU in DME after *N*-allylation under SL-PTC (Table 11, entry 1).

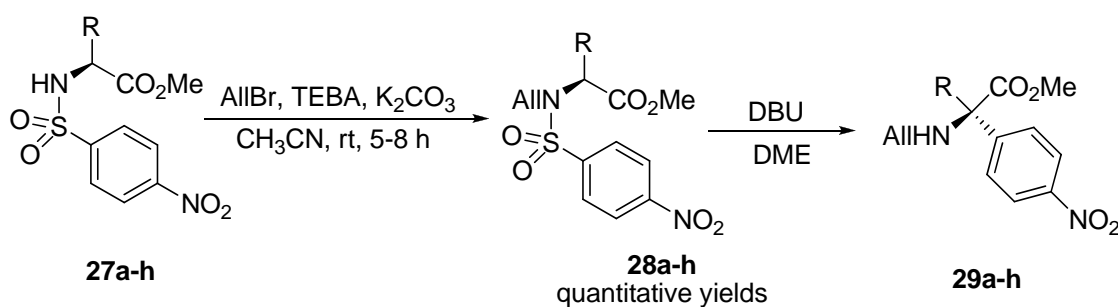

Table 11 Rearrangement of *N*-allyl phenylalanine methyl-esters **27a-h**

Entry		R		T (°C)	t (h)	29 (%)	ee (%)
1	a	Bn	Phe	0	14	95	95
2	b	Me					
3	b	Me	Ala	-50	16	90	55
4	c	4-OH-C ₆ H ₄ -CH ₂	Tyr	0	16	88	88
5	d		DHPHG	0	48	94	79
6	e		Val	25	48	93	95
7	g		Leu	25	36	78	90
8	h		Thr	25	24	90	99 (de)
9	i		<i>i</i> -Leu	25		84	99(de)

Beside nearly quantitative yields, a very high enantiomeric excess of the corresponding rearranged products **29a, c-g** (Entries 1, 4-8) and excellent diastereoselectivities of quaternary derivatives **29h-i** (Entries 9-10) were reached.

In particular, under homogeneous conditions, we synthesized derivatives **29c,h** bearing a hydroxylic function like threonine or tyrosine (Entries 4-9). On the contrary, unsatisfying enantiomeric excess were attained with the alaninate derivative **29b** (Entry 2), even operating at -50°C (Table 11, Entry 3)

Finally, we evaluated the reactivity of a series of alkyl halides RX using the

phenylalanine derivative **27a** as model compound (Table 12). The use of SL-PTC for the synthesis of *N*-alkyl derivatives was the best choice because the reaction condition did not interest the stereocentre of the amino acid and the reaction proceeds with quantitative yields under mild condition.

The application of the homogeneous transposition conditions furnished the corresponding *N*-alkylated- α -quaternary esters **29a, i-n** in excellent yields, and enantiomeric excess of 90%.

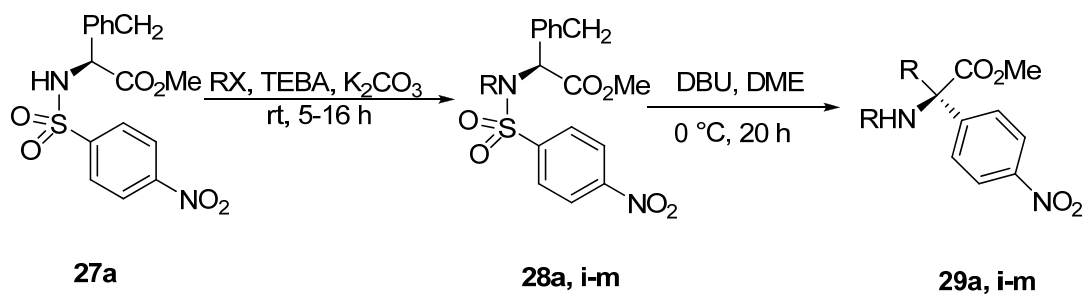

Table 12. Alkylation/Rearrangement of sulfonamide **27a** with several alkylating agents RX

Entry		R	28 (%)	29 (%)	29 ee (%)
1	a	All	98	95	95
2	i	Prg	95	84	92
3	l	Bn	96	84	90
4	m	Me	98	97	93
5	n	Bu	94	82	

6- Nucleic Acid analogues

6.1- Native Nucleic Acids⁸⁶

Nucleic acids belong to the most important components of all living organisms. In 1869, Friedrich Miescher isolated nucleic acids for the first time from pus cells and called them “Nuclein”. Due to the acidic properties of the molecule, the name “nucleic acid” was later introduced.

The two major classes of nucleic acids are constituted by deoxyribonucleic acid (DNA) and ribonucleic acid (RNA).

RNA and DNA have several similar structural properties, but clearly differ in function. While DNA is the carrier of genetic information, RNA is mainly involved in realization and regulation of gene expression although it can also act as store of genetic information (Virus)

6.1.1- Nucleic Acids structure

Nucleic acids are built from repeating nucleotides, which consists of phosphorylated sugars (ribose or deoxyribose) with attached nitrogenous bases (Figure 6.1).

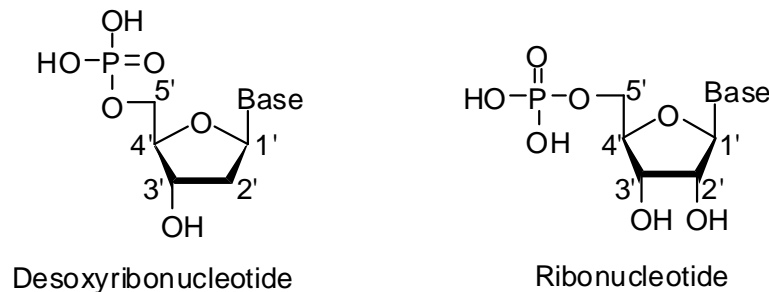

Figure 6.1

Nucleotides are linked through phosphate diesters bond, between a phosphate group present on the 5' carbon atom and the hydroxyl group present on the 3' carbon atom of the next sugar, to form the chains of DNA or RNA. The nitrogenous bases or nucleobase that it's possible find in nature in the two nucleic acid types are different: adenine,

⁸⁶ a) Metzler, D. *Biochemistry: The Chemical Reactions of Living Cells, 2nd edition, 2001*, Academic Press; b) Mathews, K.; Van Holde, K. E. *Biochemistry 2nd edition, 1996*, The Benjamin/Cummings Publishing Company, Inc

cytosine, and guanine are found in both RNA and DNA, while thymine only occurs in DNA and uracil only occurs in RNA. (Figure 6.2)

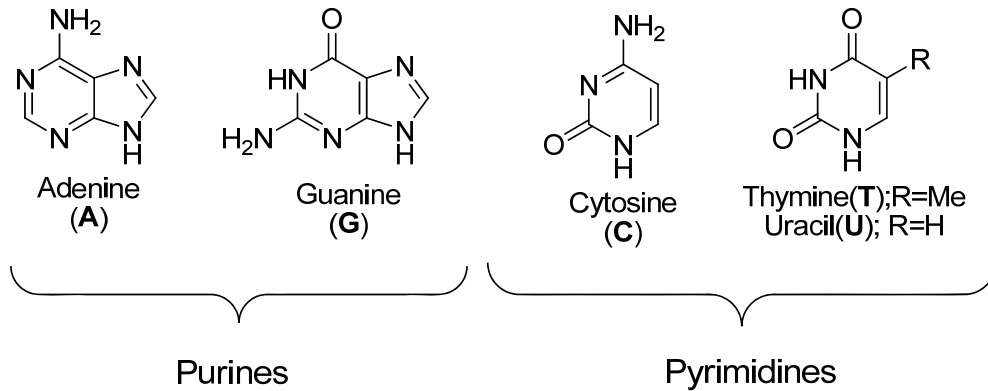

Figure 6.2

In living organisms, DNA does not usually exist as a single strand, but instead as a tightly-associated pair of polynucleotide in the shape of a double helix, with the nucleobases and sugar phosphate positioned inside and outside the helices respectively (Figure 6.3). In a double helix the direction of the nucleotides in one strand is opposite to their direction in the other strand. This arrangement of DNA strands is called antiparallel.

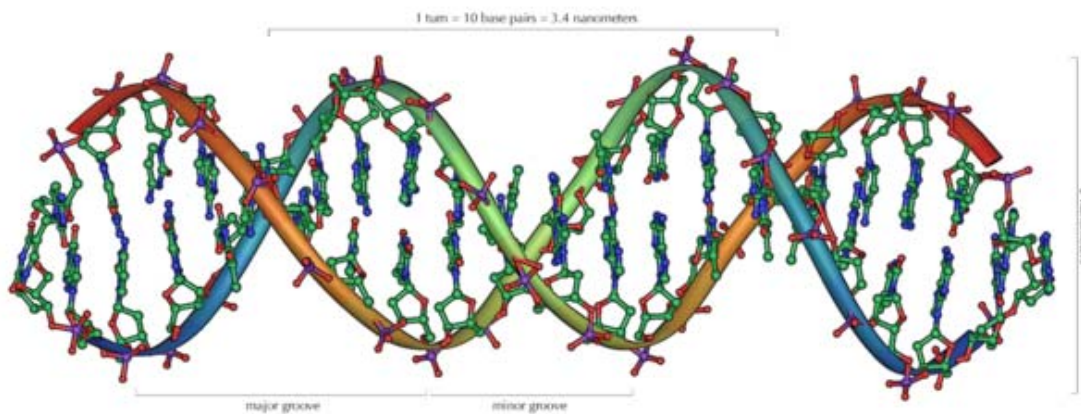

Figure 6.3

In organism the double helix has been observed in three different conformation (Figure 6.4):

A-DNA: right-handed spiral, 2.8 nm pitch, 11 nucleotides for turn and turn angle between two residues of 33°;

B-DNA: right-handed spiral, 3.4 nm pitch, 10 nucleotides for turn and turn angle between two residues of 36° ;

Z-DNA: left-handed spiral, 4.5 nm pitch, 12 nucleotides for turn and turn angle between two residues of 30°

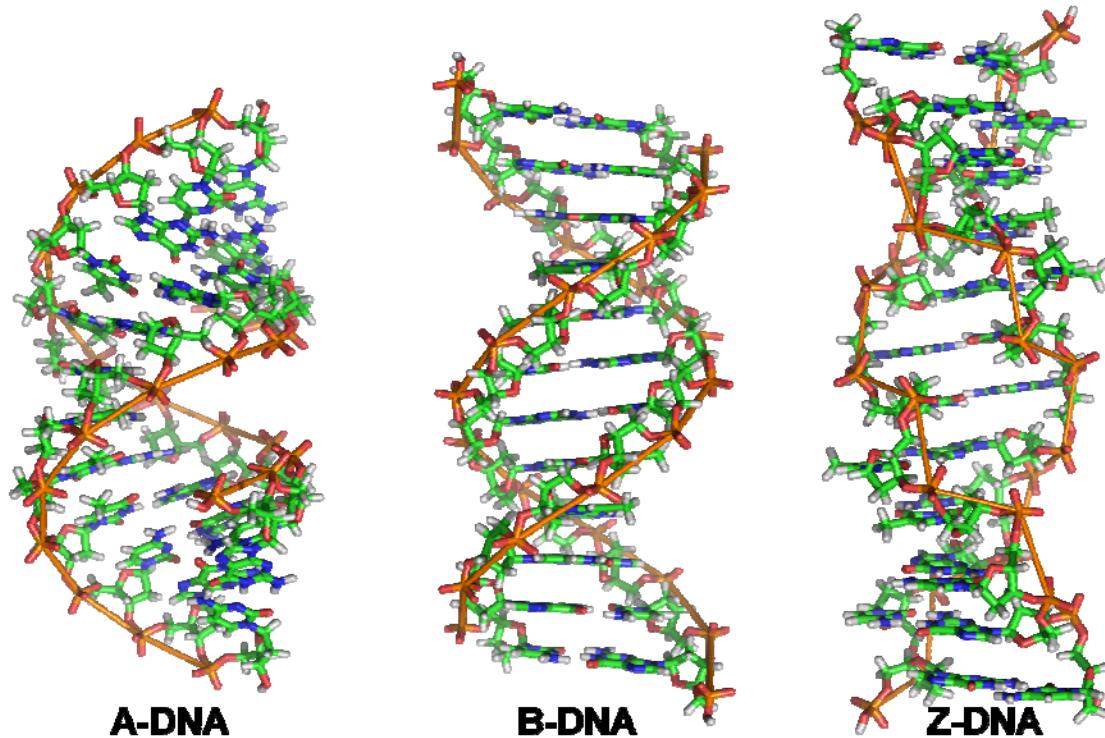

Figure 6.4

Which conformation DNA adopts depends on the sequence of the DNA, the amount and direction of supercoiling, chemical modifications of the bases and also solution conditions, such as the concentration of metal ions and polyamines. Of these three conformations, the “B” form is most common in the cell conditions, the “A” form occurs under non-physiological conditions in dehydrated samples of DNA, such as those used in crystallographic experiments, while in the cell it may be produced in hybrid pairings of DNA and RNA strands, as well as in enzyme-DNA complexes. The “Z” form, that takes his name from the typical zig-zag shape, can be observed in sequences rich of alternated guanine and cytosine residues ($\text{poly}(\text{dGC})_2$) or in segments in which bases have been chemically-modified by methylation.

All the DNA conformations are possible because, as Watson and Crick discovered in 1953, the two strands are held together by hydrogen bonds formed between unique base

pairs, always consisting of a purine in one strand and a pyrimidine in the other. Base pairing is very specific: if the purine is adenine, the pyrimidine must be thymine. Similarly, guanine pairs only with cytosine. (Figure 6.5)

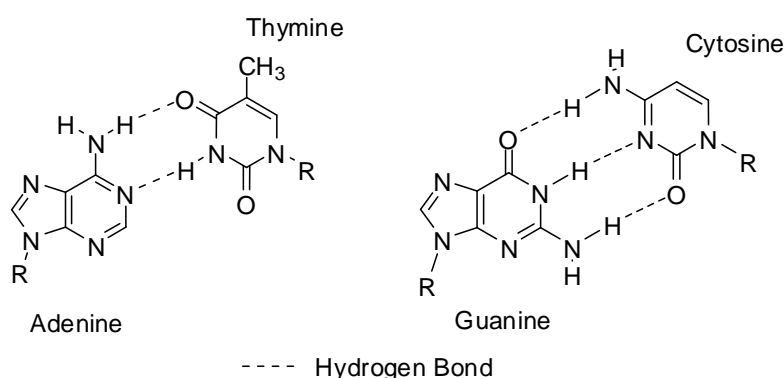

Figure 6.5

6.1.2 Replication, transcription, translation

We have said that nucleic acids are responsible of the genetic information conservation and also of the gene expression. When the cell division process occurs, the genome can be conserved in both the daughter cells by DNA replication. The gene expression is based on the transcription process. The gene contained in the DNA is transcribed into a RNA messenger (mRNA) that can be “read” from ribosome and translated into protein in a process called translation. In the next paragraphs we analyze these three fundamental cell processes.

DNA replication is the process of copying a double-stranded DNA molecule to form two new double-stranded molecules. As each DNA strand holds the same genetic information, both strands can serve as templates for the reproduction of the opposite strand. The template strand is preserved in its entirety and the new strand is assembled from nucleotides. This process is called "**semiconservative replication**". The resulting double-stranded DNA molecules are identical; proofreading and error-checking mechanisms exist to ensure near perfect fidelity. In a cell, DNA replication must happen before cell division can occur. DNA synthesis begins at specific locations in the genome, called "origins", where the two strands of DNA are separated. RNA primers attach to single stranded DNA and the enzyme DNA polymerase extends the primers to form new strands of DNA, adding nucleotides matched to the template strand. The unwinding of DNA and synthesis of new strands forms a **replication fork** (Figure 6.6).

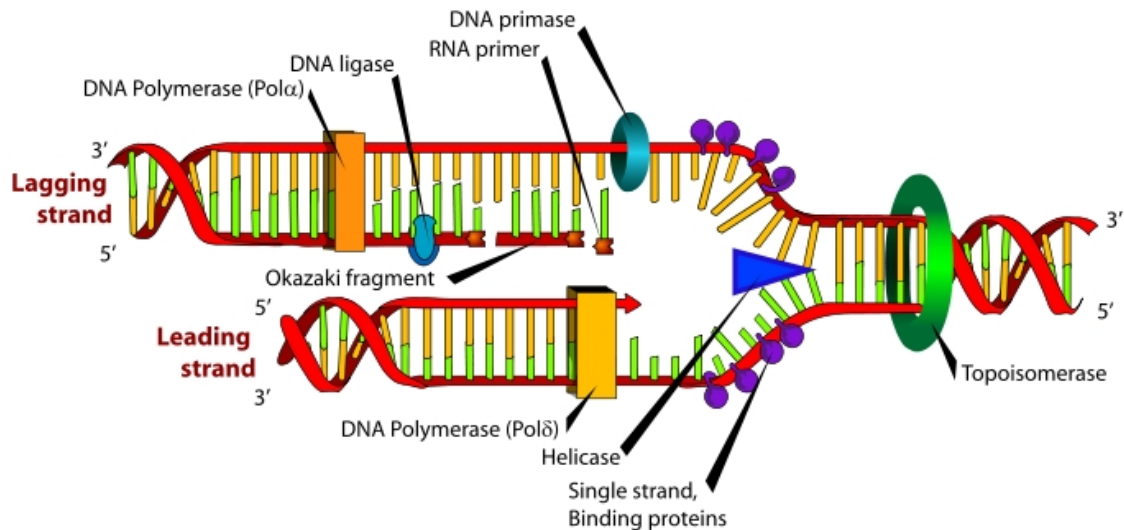

Figure 6.6

In addition to DNA polymerase, a number of other proteins are associated with the fork and assist in the initiation and continuation of DNA synthesis.

The replication fork is a structure that is formed when DNA is being replicated. It is created through the action of helicase, which breaks the hydrogen bonds holding the two DNA strands together and the resulting structure has two branching "prongs", each one made up of a single strand of DNA. Since DNA polymerases perform DNA synthesis exclusively in the 5'→3' direction, the synthesis of DNA is semidiscontinuous. The new DNA strand at the replication fork that is synthesized in the 5'→3' direction in a continuous manner is called leading strand. The other strand, built in a discontinuous way, is synthesized in short segments known as Okazaki fragments. Along the lagging strand's template, primase builds RNA primers in short bursts. DNA polymerases are then able to use the free 3' OH groups on the RNA primers to synthesize DNA in the 5'→3' direction. The RNA fragments are then removed and new deoxyribonucleotides are added to fill the gaps where the RNA was present. The deoxyribonucleotides are joined together by DNA ligase, completing the synthesis of the lagging strand.

Expression of the information in a gene generally involves production of an RNA molecule transcribed from a DNA template. During transcription, an enzyme system converts the genetic information in a segment of double-stranded DNA into an RNA strand (RNA messenger) with a base sequence complementary to one of the DNA strands (Figure 6.7).

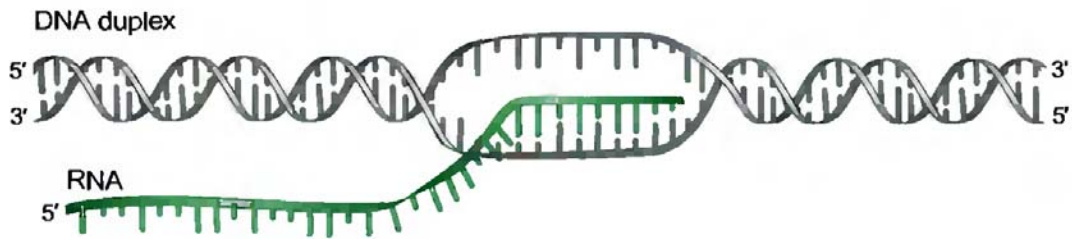

Figure 6.7

Above we have described that during replication the entire chromosome is usually copied, but transcription is more selective. Only particular genes or groups of genes are transcribed at any one time, and some portions of the DNA genome are never transcribed. The cell restricts the expression of genetic information to the formation of gene products needed at any particular moment. Specific regulatory sequences mark the beginning and end of the DNA segments to be transcribed and designate which strand in duplex DNA is to be used as the template.

The main actor of the transcription is the RNA polymerase, that produces RNA messenger, the instruction for the protein synthesis.

The transcription can be divided in three main processes: initiation, elongation, termination

Initiation

The RNA polymerase is a core enzyme consisting of five subunits: 2 α subunits, 1 β subunit, 1 β' subunit, and 1 ω subunit. At the start of initiation, the core enzyme is associated with a sigma factor that aids in finding the appropriate -35 and -10 basepairs downstream of promoter sequences.

Transcription begins with the random binding of RNA polymerase to DNA, then the enzyme move rapidly along the double helix until it locates a strong binding site where it binds to the recognition sequences of the promoter through specific interactions in the major groove of the DNA helix to the promoter in DNA. This initial specific polymerase-promoter complex is referred to as a closed complex because it is thought that the bases in the DNA chain are all still paired. After the recognition of the promoter the closed complex is converted into an open complex, which is ready to initiate *mRNA* synthesis. In the open complex, the hydrogen bonds holding together the base pairs have been

broken, and the bases of the template chain are available for pairing with incoming ribonucleotide triphosphates.

Elongation

Once RNA polymerase has bind the DNA strand the transcription can start. One strand of DNA, the template strand (or non-coding strand), is used as a template for RNA synthesis. As transcription proceeds, RNA polymerase traverses the template strand and uses base pairing complementarity with the DNA template to create an RNA copy. Although RNA polymerase moves on the template strand from 3' → 5', the coding (non-template) strand is usually used as the reference point, so transcription is said to go from 5' → 3'. This produces an RNA molecule from 5' → 3', an exact copy of the coding strand (except that thymines are replaced with uracils)

Unlike DNA replication, mRNA transcription can involve multiple RNA polymerases on a single DNA template and multiple rounds of transcription (amplification of particular *mRNA*), so many *mRNA* molecules can be produced from a single copy of a gene. This step also involves a proofreading mechanism that can replace incorrectly incorporated bases.

Termination

Encoded in DNA are not only the initiation signals for transcription but also termination signals or terminators. The simplest terminators result from GC-rich regions of dyad symmetry in the DNA. The RNA transcript is able to form a stable hairpin loop. If such a loop is followed closely by a series of uracils, the RNA and the polymerase will dissociate from the DNA template terminating transcription. The low stability of AU base pairs may facilitate dissociation, but RNA polymerase may also recognize the terminator loop.

6.1.3 Translation

Proteins are synthesized from *mRNA* templates by a process that has been highly conserved throughout evolution. All *mRNAs* are read in the 5' to 3' direction, and polypeptide chains are synthesized from the amino to the carboxy terminus. Each amino acid is specified by three bases (a codon) in the *mRNA*, according to a nearly universal genetic code (Figure 6.8).

	U	C	A	G
U	UUU } Phe UUC } UUA } Leu UUG }	UCU } Ser UCC } UCA } UCG }	UAU } Tyr UAC } UAA } Stop UAG }	UGU } Cys UGC } UGA } Stop UGG } Trp
C	CUU } Leu CUC } CUA } CUG }	CCU } Pro CCC } CCA } CCG }	CAU } His CAC } CAA } Gln CAG }	CGU } Arg CGC } CGA } CGG }
A	AUU } Ile AUC } AUA } AUG } Met	ACU } Thr ACC } ACA } ACG }	AAU } Asn AAC } AAA } Lys AAG }	AGU } Ser AGC } AGA } Arg AGG }
G	GUU } Val GUC } GUA } GUG }	GCU } Ala GCC } GCA } GCG }	GAU } Asp GAC } GAA } Glu GAG }	GGU } Gly GGC } GGA } GGG }

Figure 6.8

The basic mechanics of protein synthesis are also the same in all cells: translation is carried out on ribosomes, with *t*RNAs serving as adaptors between the *m*RNA template and the amino acids being incorporated into protein (Figure 6.9).

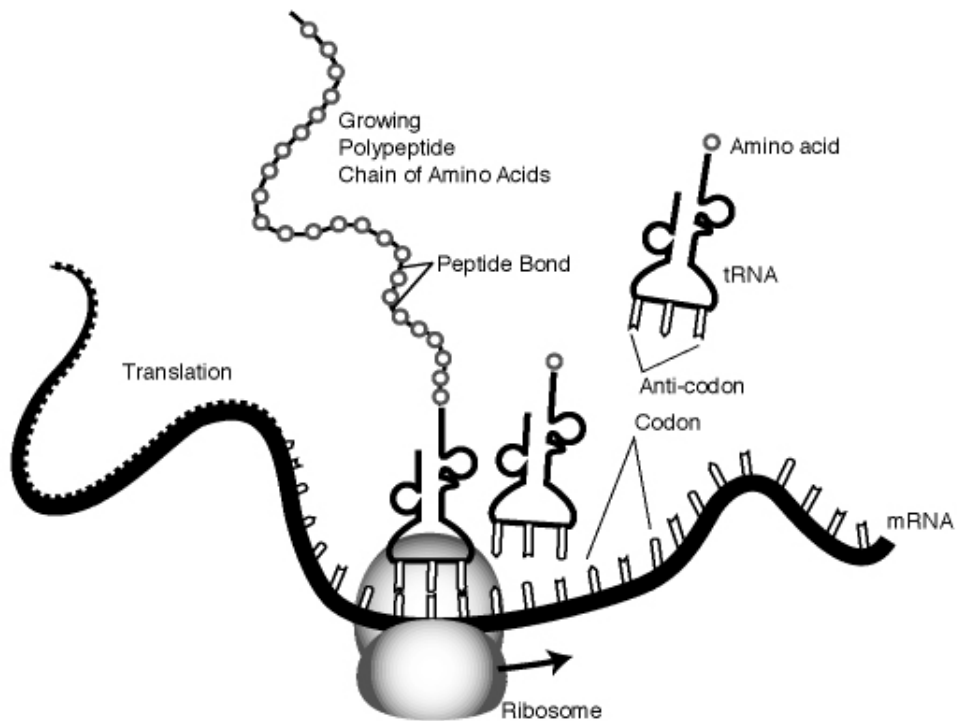

Figure 6.9

The first step is the formation of a complex between the small subunit of the ribosome, the *mRNA* and a initiator *tRNA* with the help of initiation factors.

The initiator is a *tRNA* that recognize the AUG codon on the *mRNA* and transport the *N*-formylmethionine instead a methionine.

Elongation of the polypeptide chain ensues with binding of the appropriate aminoacyl *tRNA* to the next codon in the 5' → 3' direction. Base pairs form between the anticodon of the *tRNA* and the *mRNA* codon that lies in the aminoacyl (A) site; the peptide bond is then formed by the peptidyltransferase reaction. This reaction is followed by translocation, movement of the initiator *tRNA* into an exit site at the same time that the second *tRNA* (together with its *mRNA* codon and the attached growing peptide chain) moves into the peptidyl (P) site. The elongation cycle is repeated until the peptide chain is complete.

Termination of the polypeptide happens when the A site of the ribosome faces a stop codon (UAA, UAG, or UGA). When this happens, no *tRNA* can recognize it, but a releasing factor can recognize nonsense codons and causes the release of the complete polypeptide chain.

6.1.4 DNA damage and mutation

During the normal cell process is very difficult that DNA can be damaged because, as we have seen above, the replication process is very accurate and DNA polymerase has a proofreading process. Furthermore in the cell are present some DNA repair agents that reduce the possibility of mistake in the DNA sequence.

Although the rates of spontaneous mutation are low, they can be greatly increased by mutagenic chemicals, as oxidizing or alkylating agents, and also by high-energy electromagnetic radiation such as ultraviolet light and X-rays.

Mutations can be described as:

base-pair switches: where one or more nucleobases are substituted by another nucleobases;

deletions: when one or more nucleotides are removed from the sequence;

additions: when one or more nucleotide are added to the sequence.

Of these three mutations, the one that statistically would be less problematic is the base switch; in fact, we have shown before that different codons can encode for the same amino acid. The other two categories of mutations are much more serious, since a shift in

reading codon sequence, affects all the amino acids coded after the nucleotide deleted or inserted and, subsequently, the related protein has a different structure and function.

To function correctly, each cell depends on thousands of proteins that have to work in the right places at the right times. When a mutation alters a protein that plays a critical role in the body, a medical condition can result. A condition caused by mutations in one or more genes is called a genetic disorder. However, only a small percentage of mutations cause genetic disorders; most have no impact on health. For example, some mutations alter a gene's DNA base sequence but do not change the function of the protein made by the gene.

If a mutation is present in a germ cell, it can give rise to offspring that carries the mutation in all of its cells. This is the case in hereditary diseases. On the other hand, a mutation can occur in a somatic cell of an organism. Such mutations will be present in all descendants of this cell, and certain mutations can cause the cell to become malignant, and thus cause cancer.

Mutations are not always negative, a very small percentage of mutations can have a positive effect and evolution is based on genetic mutations. These mutations lead to new versions of proteins that help an organism and its future generations to better adapt to changes in their environment.

6.2 Nucleic Acid analogues: Locked Nucleic Acids (LNA)

LNA was first described by Singh et al. 1998,⁸⁷ as a novel class of conformational restricted oligonucleotide analogs. LNA is a bicyclic nucleic acid where a ribonucleoside 2'-oxygen is linked to the 4'-carbon atom with a methylene unit, as shown in Figure 6.10.

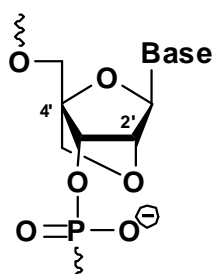

Figure 2.3

⁸⁷ Singh, S. K.; Koshkin, A.A.; Wengel, J.; Nielsen, P. *Chem. Commun.* **1998**, 455-456.

The constraint on the sugar moiety results in a locked 3'-endo conformation that prepares the base for high affinity hybridization.⁸⁸ Its close structural resemblance to RNA, high affinity and specificity toward the target strand, high *in vivo* stability, lack of toxicity, and ease of transfection into cells, have contributed to its success as a promising tool in therapeutics and functional genomics. Furthermore, LNA oligonucleotides can be synthesized using conventional phosphoramidite chemistry, thus, allowing automated synthesis of fully modified LNA and chimeric oligonucleotides such as LNA/DNA and LNA/RNA. Finally, their charged phosphate backbone allows ready delivery into cells using standard cationic transfection agents.

6.2.1 LNA family

A number of structural analogues of LNA have been synthesized (Figure 2.4) and investigated for various attributes.⁸⁹ Although most members of the LNA family exhibit high binding affinity to RNA, the binding efficiency of β -D-LNA (parent LNA) is known to be the highest of all the diastereomeric forms. Among the other stereoisomers, α -L-LNA caught the attention as it displayed thermostability properties only slightly inferior to the parent LNA. Such remarkable binding affinity and specificity, obtained for LNA and R-L-LNA when fully and partially modified, have established these molecules as unique nucleic acid mimics.

These molecules, along with other derivatives containing the 2'-heteroatom to 4'-C linkage (Figure 6.11), were tested *in vivo* for their antisense efficacy and were found to be very effective. However, each of these molecules exhibit different pharmacokinetic profiles, thereby, opening new avenues towards the choice of LNA chemistry to suit the desired profiles.

⁸⁸ a) Koshkin, A. A.; Singh, S. K.; Nielsen, P.; Rajwanshi, V. K.; Kumar, R.; Meldgaard, M.; Olsen, C. E.; Wengel, J. *Tetrahedron*. **1998**, *54*, 3607-3630; b) Koshkin, A. A.; Nielsen, P.; Meldgaard, M.; Rajwanshi, V. K.; Singh, S. K.; Wengel, J. *J. Am. Chem. Soc.* **1998**, *120*, 13252-13253; c) Singh, S. K.; Wengel, J. *Chem. Commun.* **1998**, 1247-1248; d) Wengel, J. *Accounts of Chemical Research*. **1999**, *32*, 301-310; e) Wengel, J.; Petersen, M.; Nielsen, K. E.; Jensen, G. A.; Håkansson, A. E.; Kumar, R.; Sørensen, M. D.; Rajwanshi, V. K.; Bryld, T.; Jacobsen, J. P. *Nucleosides Nucleotides Nucleic Acids*. **2001**, *20*, 389-96; f) Wahlestedt, C.; Salmi, P.; Good, L.; Kela, J.; Johnsson, T.; Hökfelt, T.; Broberger, C.; Porreca, F.; Lai, J.; Ren, K.; Ossipov, M.; Koshkin, A.; Jakobsen, N.; Skouv, J.; Oerum, H.; Jacobsen, M. H.; Wengel, J. *Proc Natl Acad Sci U S A*. **2000**, *97*, 5633-8.

⁸⁹ a) Rajwanshi, V. K.; Håkansson, A. E.; Sørensen, M. D.; Pitsch, S.; Singh, S. K.; Kumar, R.; Nielsen, P.; Wengel, J. *Angew. Chem. Int. Ed.* **2000**, *39*, 1656-1659; b) Fluiter, K.; Frieden, M.; Vreijling, J.; Rosenbohm, C.; Wissel, M. B. D.; Christensen, S. M.; Koch, T.; Hrum, H.; Baas, F. *ChemBioChem*. **2005**, *6*, 1104-1109

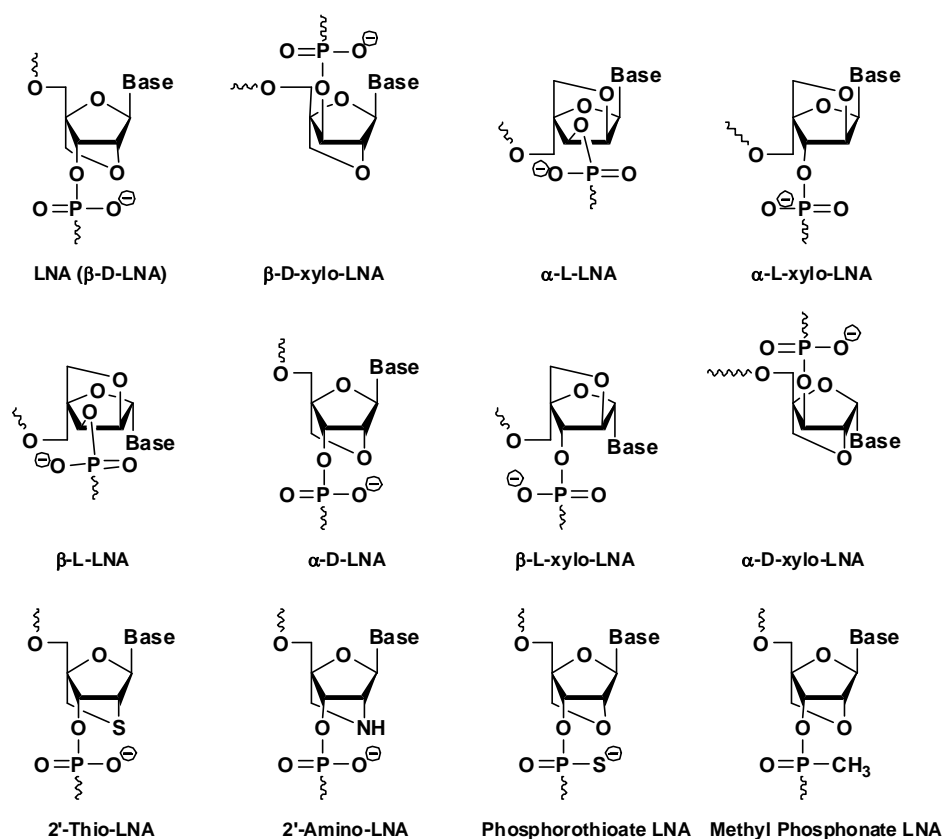

Figure 6.11

6.2.2 Properties of locked nucleic acid

LNA is a general and versatile tool for specific high-affinity recognition of single-stranded DNA (ssDNA) and ssRNA. The hybridization properties of LNA containing oligonucleotides, have been evaluated in different sequence contexts with oligomers ranging from 6 to 20 nucleotides with varying levels of LNA content including, for example, fully modified LNA, LNA/DNA mixmers, LNA/RNA mixmers, and LNA/PS-DNA mixmers^{12,15,20,21}. The unprecedented hybridization potential of LNA with either RNA or DNA targets is reflected in the increased thermostability of the LNA containing duplexes. Substitution by an LNA monomer leads to an increase of T_m values up to +1 to +8°C against DNA and an increase of +2 to +10°C against RNA.⁹⁰ This is possibly the largest increase in thermostability observed for a nucleic acid analogue, but it does

⁹⁰ a) Baker, B. F.; Lot, S. S.; Condon, T. P.; Cheng-Flournoy, S.; Lesnik, E. A.; Sasmor, H. M.; Bennett, C. F. *J. Biol. Chem.* **1997**, *272*, 11994-12000; b) Obika, S.; Hemamayi, R.; Masuda, T.; Sugimoto, T.; Nakagawa, S.; Mayumi, T.; Imanishi, T. *Nucleic Acids Res Suppl.* **2001**, 145-6.

saturate when the relative substitution by LNA monomer reaches to about 50% of the total residues in the LNA/DNA chimera.⁹¹

Furthermore, the impact on the thermostability depends on the oligomer length and composition. Since, LNA/LNA base pairing is very strong, the self-annealing capacity of LNA must be taken into account when designing fully modified LNA or LNA mixmers with a large number of LNA substitutions. Due to the strong base pairing in LNA-LNA duplexes, it is important to design LNAs without extensive self-complementary segments or to apply chimeric LNAs (LNA-DNA or LNA-RNA).

The artificial gene regulation studies can be carried out by targeting DNA duplex with oligonucleotides to form a DNA triple helix, thereby inhibiting transcription. The triplex-forming oligonucleotide (TFO)⁹² binds to a purine-pyrimidine double-stranded DNA (dsDNA) duplex in the major groove through specific hydrogen bonds. In a parallel motif, a homopyrimidine TFO binds to the target duplex by Hoogsteen hydrogen bonding to form T:A:T and C⁺:G:C base triplets.

There are certain factors that severely affect the antisense strategy, such as the nature of Hoogsteen hydrogen bond arrangement that only permits purine-pyrimidine dsDNA to be targeted and the rigid requirement that the cytosine bases in the TFO must be protonated, which requires acidic conditions. LNAs play a prominent role in alleviating these limitations to a great extent. In LNA, the sugar is locked in a C3'-endo (*N*-type and RNA-like) conformation by 2'-O, 4'-C methylene bridge. LNAs containing TFOs stabilize triplex formation and allow its formation at physiological pH. TFOs with LNA nucleotides at every second or third position form extremely stable triplexes, while fully modified LNA TFOs are not able to form triplexes at all due to their rigidity as supported by structural studies of Gotfredsen et al.⁹³ Thus, the optimum design for LNA TFOs is LNA-DNA chimera with alternating LNA monomers and DNA monomers.

LNA-RNA and LNA-DNA are the two possible LNA hybrids of interest. These hybrids retain features common to native nucleic acid duplexes, such as Watson-Crick base pairing, nucleobases in the antiorientation, base stacking, and a right-handed helical conformation.

⁹¹ Kvarno, L.; Kumar, R.; Dahl, B.; Olsen, C.; Wengel, J. *J. Org. Chem.* **2000**, *65*, 5167-5176.

⁹² Kaur, H.; Babu, B.; Maiti, S. *Chem. Rev.* **2007**, *107*, 4672-4697.

⁹³ Gotfredsen, C.; Schultze, P.; Feigon, J. *J. Am. Chem. Soc.* **1998**, *120*, 4281-4289.

In LNA–RNA hybrids, NMR spectroscopic studies indicate that there is an increase in the A-like character with increase in the LNA content of LNA strands.⁹⁴ The LNA nucleotide also perturbs the sugar puckers of the neighboring nucleotides predominantly in the 3' direction in the case of LNA–RNA hybrid with one modification. However, RNA strands are rather unperturbed by differing the number of LNA monomers in the cognate strands. This is consistent with the fact that the RNA strands in duplexes are usually rigid and A-like. The structural saturation phenomenon was observed whereby increase in helical thermostability per LNA monomer (relative to native reference duplexes) reaches a maximum for LNAs containing less than 50% LNA monomers. When LNA monomers are incorporated into dsDNA duplexes, generally the B-like character of the duplexes decreases as LNA monomers are incorporated. The LNA monomers alter the sugar pucker of 3'-flanking nucleotides from a preferential S-type pucker in dsDNA duplexes to a mixture of N- and S-type conformations. For nucleotides located between two modifications, a further perturbation to an N-type sugar pucker and thus a cooperative effect is observed. In LNA–DNA hybrids, the cognate DNA strands respond to the more A-like geometry of the LNA strand by slightly increasing the population of N-type sugar puckers.

LNA is one of the most useful modified backbones, as incorporation of a single LNA provides a substantial increase in duplex stability.⁹⁵ This lead to the design of LNA-incorporated nucleic acid probes and primers. LNA incorporated probes can be efficiently designed by studying the thermodynamics for LNA incorporation. It was found that LNA pyrimidines contribute more stability than purines, but there is a context-dependence for each LNA base incorporated. LNAs stabilize the duplex by either preorganization or improved stacking, but not both simultaneously.

The melting properties of oligonucleotides can be routinely investigated by UV spectrophotometer and fluorescence measurement in a real-time PCR instrument.

6.2.3 Applications of locked nucleic acids

Oligonucleotides containing LNA not only exhibit unprecedented thermal stabilities toward complementary DNA and RNA, but also exhibit excellent mismatch discrimination. For the SNP genotyping studies, the high binding affinity of LNA oligoes

⁹⁴ Petersen, M.; Wengel, J. *Trends Biotechnol.* **2003**, *21*, 74-81.

⁹⁵ Karkare, S.; Bhatnagar, D. *Appl. Microbiol. Biotechnol.* **2006**, *71*, 575-586.

allows the use of short probes. LNA has also proved to be beneficial for allele specific PCR and *mRNA* sample preparation. LNA is best recommended for use in any hybridization assay requiring high specificity and/or reproducibility, e.g., dual-labeled probes, in situ hybridization probes, molecular beacons, and PCR primers. Furthermore, LNA offers the possibility to adjust T_m values of primers and probes in multiplex assays. Because of these significant characteristics, the use of LNA-modified oligoes is becoming popular in the field of antisense drug development and therapeutics.

Therapeutic applications

The chemical and biophysical property of LNA makes it a good antisense molecule for therapeutics. LNA antisense oligonucleotide obeys Watson–Crick base pairing rules; it is stable in serum and can be taken up by mammalian cells and show low toxicity in vivo.⁹⁶ The RNase H activation potential of LNAs in a gapmer design has been successfully used to silence expression of Intracellular adhesion molecule-1 (ICAM-1).⁹⁷ LNA monomers can also be incorporated into the binding arms of the DNAzyme to yield LNAzyme.⁹⁸ The introduction of LNAzymes in therapeutics can be an important step toward the realization of oligonucleotidi based therapeutics with intrinsic endonucleolytic activity.

Diagnostic applications

A large number of diseases are associated with single nucleotide polymorphism (SNPs) in the genetic code. The traditional methods of scanning SNPs involve enzymatic digestion or gel electrophoresis; therefore, they are time consuming and involve automation problems. LNA technology was employed to design efficient and simple SNP assays. These assays are based on efficient single nucleotide mismatch discrimination by LNA than by DNA.⁹⁹ These assays, in general, employ probes (complementary to the wild-type or the mutated genomic sequence) and are subjected to PCR amplicon hybridization. These probe sequences hybridize to target DNA without a mismatch. The hybridization with target DNA can be detected by spectrophotometer or

⁹⁶ Obika, S.; Nanbu, D.; Hari, Y.; Andoh, J.; Morio, K.; Doi, T.; Imanishi, T. *Tetrahedron Letters*. **1998**, *39*, 5401-5404.

⁹⁷ Obika, S.; Hemamayi, R.; Masuda, T.; Sugimoto, T.; Nakagawa, S.; Mayumi, T.; Imanishi, T. *Nucleic Acids Res Suppl*. **2001**, 145-6.

⁹⁸ Vester, B.; Lundberg, L.; Sorensen, M.; Babu, B.; Douthwaite, S.; Wengel, J. *J. Am. Chem. Soc.* **2002**, *124*, 13682-13683.

⁹⁹ Orum, H.; Jakobsen, M. H.; Koch, T.; Vuust, J.; Borre, M. B. *Clin.Chem*. **1999**, *45*, 1898-1905.

by fluorescence polarization detection.¹⁰⁰ The high affinity, efficient mismatch discrimination, and multiplexing promised by LNA will make it useful for diagnostics. The screening for the factor V Leiden mutation is an example of LNA genotyping assay. Besides these, LNA decoys can also be designed that interact with the target factor, which results into incapacitation of the protein for subsequent binding to the promoter regions of target genes.¹⁰¹

6.3 Nucleic Acid analogues: Peptide Nucleic Acids (PNA)

Peptide nucleic acids (PNAs), first introduced in 1991 by Nielsen,¹⁰² are synthetic nucleic acid analogues with an achiral pseudopeptide backbone in which the phosphodiester backbone is replaced by repetitive units of *N*-(2-aminoethyl)glycine to which the purine and pyrimidine bases are attached via a methyl carbonyl linker. Usually, PNA is an oligomer of 6-15 monomeric units (Figure 6.12).

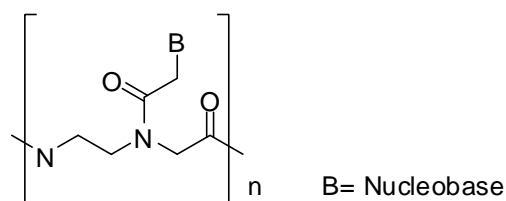

Figure 6.12

6.3.1 Properties of peptide nucleic acid

The PNA backbone maintains the same approximate length per repeating unit as in DNA or RNA and the appended nucleobases project from the backbone to form stable double or triple helical complexes with target nucleic acids.¹⁰³ The internucleobase distance in PNA is conserved, allowing its binding to the target DNA or RNA sequences with high sequence specificity and affinity. Since PNAs have a neutral backbone, hybridization with target nucleic acids is not affected by the interstrand negative charge

¹⁰⁰ Simeonov, A.; Nikiforov, T. T. *Nucleic Acids Res.* **2002**, *30*, 91.

¹⁰¹ Crinelli, R.; Bianchi, M.; Gentilini, L.; Magnani, M. *Nucl. Acids Res.* **2002**, *30*, 2435-2443.

¹⁰² Nielsen, P.; Egholm, M.; Berg, R.; Buchardt, O. *Science.* **1991**, *254*, 1497-1500.

¹⁰³ Egholm, M.; Buchardt, O.; Christensen, L.; Behrens, C.; Freier, S. M.; Driver, D. A.; Berg, R. H.; Kim, S. K.; Norden, B.; Nielsen, P. E. *Nature.* **1993**, *365*, 566-8.

electrostatic repulsions.¹⁰⁴ For this reason, the binding between PNA/DNA strands is stronger than between DNA/DNA strands: experiments with homopyrimidine strands (strands consisting of only one repeated pyrimidine base) have shown that the T_m ("melting" temperature) of a 6-base thymine PNA/adenine DNA double helix was 31°C in comparison to an equivalent 6-base DNA/DNA duplex that denatures at a temperature less than 10°C.

In addition, the absence of repetitive charged backbone prevents PNAs from binding to proteins that normally recognize polyanions, avoiding a major source of nonspecific interactions.

PNAs have poor water solubility compared with DNA (this is the major limitations of the therapeutic applications of PNAs). Neutral PNA molecules have a tendency to aggregate, that is dependent on the sequence of the oligomer. PNA solubility is also related to the length of the oligomer and to the purine/pyrimidine ratio.¹⁰⁵ Improvement of the aqueous solubility of PNAs has been achieved by the introduction of charges in the molecule,¹⁰⁶ or by the introduction of ether linkages in the backbone. PNAs are endowed of positive charges by linking a terminal lysine residue 2, 42, 43 (Figure 3.12a) or by the introduction of a positive charge in the backbone, or by replacing the acetamide linker to the nucleobase by a flexible ethylene linker (Figure 3.12b) 44.

Substitution of natural bases for analogues can also be used for interfering with the hybridisation process¹⁰⁷ or to yield fluorescent PNA monomers and oligomers.¹⁰⁸

6.4 Morpholinos

Morpholinos are synthetic molecules which are the product of a natural nucleic acid structure redesign (Figure 2.1). The standard nucleic acid bases are bound directly to

¹⁰⁴ Smulevitch, S. V.; Simmons, C. G.; Norton, J. C.; Wise, T. W.; Corey, D. R. *Nat Biotech.* **1996**, *14*, 1700-1704.

¹⁰⁵ Hyrup, B.; Nielsen, P. E. *Bioorg. Med. Chem.* **1996**, *4*, 5-23.

¹⁰⁶ Gildea, B. D.; Casey, S.; MacNeill, J.; Perry-O'Keefe, H.; Sorensen, D.; Coull, J. M. *Tetrahedron Letters.* **1998**, *39*, 7255-7258.

¹⁰⁷ a) Christensen, L.; Hansen, H. F.; Koch, T.; Nielsen, P. E. *Nucleic. Acids. Res.* **1998**, *26*, 2735- 2739; b) Eldrup, A.; Dahl, O.; Nielsen, P. *J. Am. Chem. Soc.* **1997**, *119*, 11116-11117.

¹⁰⁸ a) Koler, O.; Seitz, O. *Chem. Comm.* **2003**, 2938-9; b) Koler, O.; Jarikote, D. V.; Seitz, O. *ChemBioChem.* **2005**, *6*, 69-77; c) Jarikote, D. V.; Koler, O.; Socher, E.; Seitz, O. *Eur. J. Org. Chem.* **2005**, 3187-3195.

morpholine rings obtained from the chemical transformation of the desoxyribose sugar rings.

There are three steps in morpholino synthesis.

The key steps in synthesis of morpholino subunits are oxidative opening of the 5-membered ribose ring, closing the resulting dialdehyde on ammonia to give a 6-membered morpholine ring, and reductive removal of the original 2' and 3' hydroxyls as shown in Figure 2.1

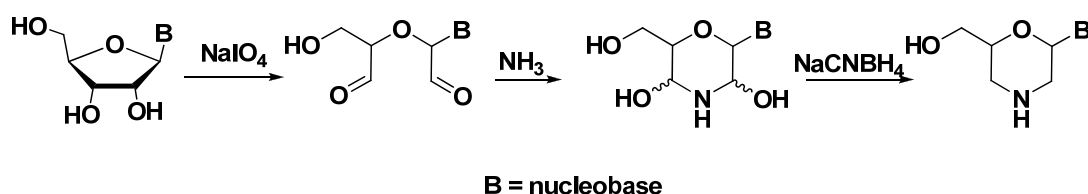

Figure 2.1

Since their discovery a substantial number of intersubunit linkage types has been developed, including the carbonyl, sulfonyl, and phosphoryl linkages (Figure 2.2).

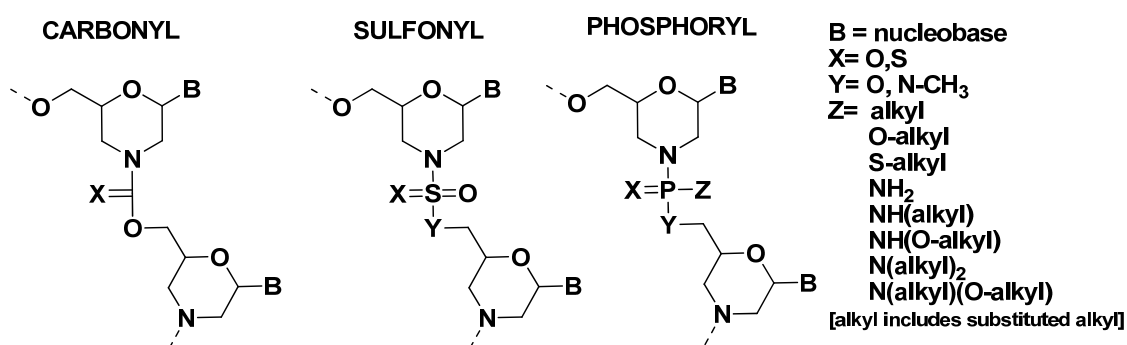

Figure 2.2

Although Morpholino oligos containing a number of such linkages provide effective binding to targeted genetic sequences, the phosphorodiamidate is the most used for many reasons: cost and ease of synthesis, chemical stability, aqueous solubility and affinity and homogeneity of binding to RNA.

6.4.1 Properties of morpholino

Solubility

The standard nonionic phosphorodiamidate-linked morpholino oligos are highly soluble in water because they exhibit excellent base stacking, even better than that in

DNA.¹⁰⁹ When nucleobases in an aqueous solution are poorly stacked, then oligo has poor water solubility because of the difficulty of inserting the hydrophobic faces of the unstacked bases into an aqueous environment. A morpholino oligo, having the more rigid carbamate intersubunit linkages, is several hundred fold less water soluble than a corresponding morpholino oligo containing a more flexible sulfamide or phosphoroamidate intersubunit linkages. The possible reason for the difference in the solubility of morpholino subtypes, is the restricted rotation of the carbamate linkage, which prevents stacking of the bases. That dissolution in an aqueous environment requires an energetically unfavorable insertion of the hydrophobic faces of the unstacked bases into water, while the free rotations of the phosphorodiamidate and sulfamide linkages allow excellent stacking of the bases.

Stability

Morpholino oligos are completely resistant to nucleases and other degradative factors in biological system, such as degradative enzymes present in blood and within cells.¹¹⁰ Thus, they are effective in long-term experiments and they are free of side reactions. A further advantage of using a backbone structure that is not degraded in the body, is that it avoids concerns that modified nucleosides or nucleotides resulting from degradation of an antisense oligo might be toxic or might be incorporated into cellular genetic material and thereby lead to mutations or other undesired biologic effects.

To enhance the ability of morpholino to invade RNA secondary structure and to increase T_m , thymine is used in place of uracil in the production of morpholinos.

The fluorescein-labeled morpholinos scrape-loaded into cells are distributed throughout the cytosol and nucleus;¹¹¹ therefore, they have access to their target RNAs during the brief stay of the RNA in the nucleus and during their long residence in the cytosol. The morpholino backbone is also stable to strong bases, but is cleaved by strong acids such as trifluoroacetic acid.

¹⁰⁹ Kang, H.; Chou, P.; JR, W. C. J.; Weller, D.; Huang, S.; Summerton, J. E. *Biopolymers*. **1992**, *32*, 1351-1363.

¹¹⁰ a) Hudziak, R. M.; Barofsky, E.; Barofsky, D. F.; Weller, D. L.; Huang, S. B.; Weller, D. D. *Antisense Nucleic Acid Drug Dev.* **1996**, *6*, 267-72; b) Taylor, M. F.; Paulauskis, J. D.; Weller, D. D.; Kobzik, L. *J. Biol. Chem.* **1996**, *271*, 17445-17452.

¹¹¹ Partridge, M.; Vincent, A.; Matthews, P.; Puma, J.; Stein, D.; Summerton, J. *Antisense Nucleic Acid Drug Dev.* **1996**, *6*, 169-75.

Specificity

To meet the challenge of specificity, the oligoes should have a “minimum inactivating length” (MIL)¹⁰ sufficiently long enough to avoid attack on essentially all nontarget sequences in the cellular RNA pool. MIL can be defined as the shortest length of oligo of a given structural type, which achieves substantial target inhibition at concentrations typically achieved in the cytosol-nuclear compartment of treated cells. Measured MIL value for a given structural type varies somewhat as a function of sequence, G+C content, and the concentration of the oligoes tested. There are two crucial design requirements for high efficacy and high specificity of oligo in a complex system.

First, the MIL value of the oligo must be sufficiently large so that the oligo has little chance of inactivating nontargeted species in the system’s entire pool of RNA transcripts. Second, to achieve high efficacy, the length of the oligo should be sufficiently longer than its MIL. Based on the RNase H-competency, there are two antisense classes, namely, RNase H-competent oligoes (i.e., DNA, S-DNA, and chimerics) and RNase H independent oligoes. Morpholino belong to the class of RNase H-independent oligoes. The challenge for RNase Hcompetent oligoes is to distinguish a single selected target sequence from the vast pool of RNA sequences. Morpholinos (particularly the new higher affinity morpholinos containing thymines instead of uracils) are generally effective against most sequences from the 5’cap to about 25 bases past the AUG translational start site of any selected mRNA (Summerton 1999). This challenge is not critical in a case of RNase H-independent oligoes like morpholino as they are only required to distinguish their target sequences from about 2-5% of the sequences comprising the RNA pool (the other 95-98% being introns and sequences of about more than 25 bases 3’ to the translational start site). Thus, morpholino can efficiently achieve exquisite specificity, an important property for antisense oligo.

Binding affinity and Antisense efficacy

Morpholino binding affinity for complementary genetic sequences is relatively insensitive to the ionic strength of the medium. Morpholino-RNA duplexes are more stable than corresponding DNA-RNA duplexes, and much more stable than the corresponding S-DNA-RNA duplexes.

Because of the excellent RNA binding affinity of oligos of this phosphorodiamidate-linked Morpholino structural type, it seemed likely Morpholino oligos would be

effective in blocking translation of their targeted mRNAs. In cell-free translation experiments using a sensitive luciferase reporter, Summerton have demonstrated that a Morpholino oligo 25 subunits in length, in both the presence and absence of RNase H, inhibits its targeted mRNA somewhat better than the corresponding S-DNA oligo in the presence of added RNase H, with both showing good efficacy at concentrations of 10 nM and above.

2.1.3 Applications of Morpholinos

Morpholinos are used primarily for classical antisense applications in complex systems. They are used for application such as correcting splicing errors in premRNAs in cultured cells and in extracorporeal treatment of cells from thalassemic patients. The most demanding application of morpholinos is in developmental biology due to its antisense application. A particular interesting application in developmental biology is the use of morpholinos to selectively target zygotic RNAs without concomitant inhibition of maternal RNAs coded by the same gene. For this intron-exon splice, junctions are targeted, which are present in the newly transcribed zygotic pre-mRNAs, but absent from the already spliced maternal mRNAs. In the year 2000, the field of developmental biology was revolutionized by morpholinos, as it provided specific, reliable tools for blocking the expression of any selected gene throughout the course of embryogenesis in model organisms such as zebra fish, frog, sea urchin, and chick.¹¹²

¹¹² Ekker, S. C.; Larson, J. D. *genesis*. 2001, 30, 89-93.

7- Results

7.1-Introduction

In the last few years, the scientific attention on the synthesis of optically pure C-substituted morpholines has getting higher, considering the wide spectrum of powerful biological activities of these derivatives: besides their applications in antisense chemistry, morpholines are used as antitumors,¹¹³ antidepressants,¹¹⁴ antioxidants,¹¹⁵ antiparasitic,¹¹⁶ and in agrochemicals.¹¹⁷

Recently, we reported a straightforward and general protocol for the synthesis of 2,6-disubstituted morpholines by nucleophilic ring opening of two different oxiranes with tosylamide, under SL-PTC conditions. The side chains of the resulting amidodiol, have been differentiated by protection of one of the hydroxy groups, before the second ring opening, and activation of the second formed hydroxyl group. The synthetic protocol has been completed by O-deprotection and cyclization to the corresponding N-tosyl morpholines (Scheme 7.1).¹¹⁸

¹¹³ a) Kim, D. K.; Ryu, D. H.; Lee, J. Y.; Lee, N.; Kim, Y. W.; Kim, J. S.; Chang, K.; Im, G. J.; Kim, T. K.; Choi, W. S. *J. Med. Chem.* **2001**, *44*, 1594. b) Acton, E. M.; Tong, G. L.; Mosher, C. W.; Wolgemuth, R.L. *J. Med. Chem.* **1984**, *27*, 638.

¹¹⁴ a) Fish, P. V.; Deur, G.; Gan, X.; Greene, K.; Hoople, D.; Mackenny, M.; Para, K. S.; Reeves, K.; Ryckmans, T.; Stiff, C.; Stobie, A.; Wakenhut, F.; Whitlock, G. A. *Bioorg. Med. Chem. Lett.* **2008**, *18*, 2562. b) Kelley, J. L.; Musso, D. L.; Boswell, G. E.; Soroko, F. E.; Cooper, B. R. *J. Med. Chem.* **1996**, *39*, 347.

¹¹⁵ Chrystelis, M. C.; Reka, E. A.; Siskou, I. C.; Kourounakis, P. N. *J. Med. Chem.* **2002**, *45*, 5406.

¹¹⁶ Kuettel, S.; Zambon, A.; Kaiser, M.; Brun, R.; Scapozza, L.; Perozzo, R. *J. Med. Chem.* **2007**, *50*, 5833.

¹¹⁷ a) Zhou, L.; Civitello, E. R.; Gupta, N.; Silverman, R. H.; Molinaro, R. J.; Anderson, D. E.; Torrence, P. F. *Bioconjugate Chem.* **2005**, *16*, 383. b) Nelson, M. H.; Stein, D. A.; Kroeker, A. D.; Hatlevig, S. A.; Iversen, P. L.; Moulton, H. M. *Bioconjugate Chem.* **2005**, *16*, 959. c) Summerton, J.; Weller, D. *Antisense Nucleic A.* **1997**, *7*, 187. d) Geller, B. L.; Deere, J. D.; Stein, D. A.; Kroeker, A. D.; Moulton, H. M.; Iversen, P. L. *Antimicrob. Agents Ch.* **2003**, *47*, 3233. e) Deere, J.; Iversen, P.; Geller, B. L. *Antimicrob. Agents Ch.* **2005**, *49*, 249. f) Tilley, L. D.; Mellbye, B. L. Puckett, S. E.; Iversen, P. L.; Geller, B. L. *J. Antimicrob. Chemoth.* **2007**, *59*, 66.

¹¹⁸ Penso, M.; Lupi, V.; Albanese, D.; Foschi, F.; Landini, D.; Tagliabue, A. *Synlett*, **2008**, *16*, 2451-2454.

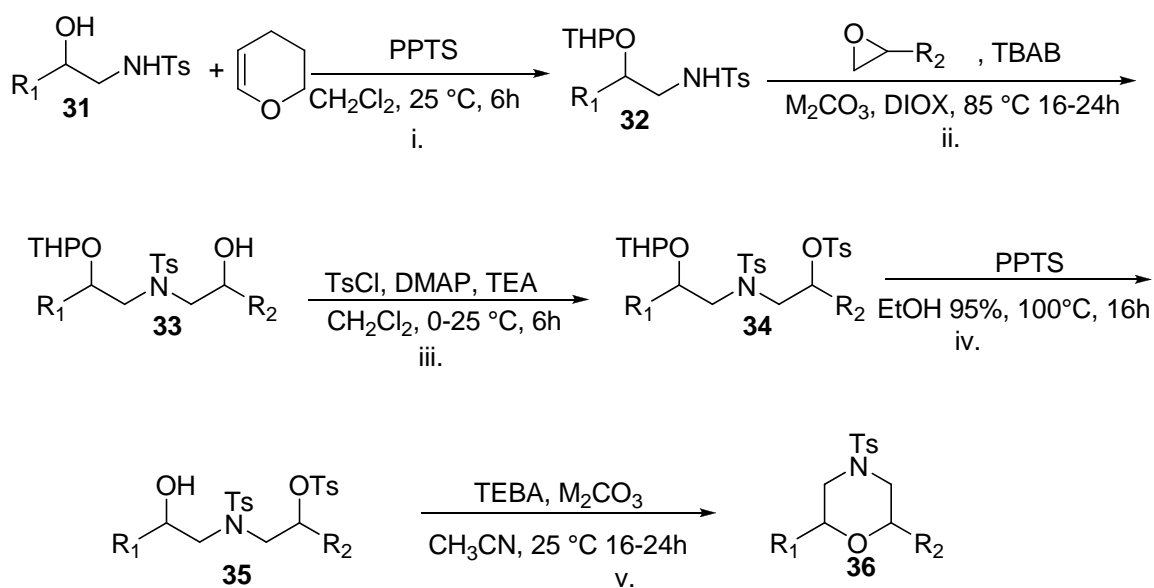

Scheme 7.1

In order to both improve the morpholines overall yields and simplify the process, we investigated the regioselective conversion into a leaving group of only one hydroxy group of the amidodiols synthesised by consecutive double oxirane ring-opening. This protocol, which do not include a protection/deprotection step, ends with the regioselective ring-closing of the mono-sulfonated diol, with stereoselective morpholine formation. Preliminary runs, conducted on diol **37a** (Scheme 2) evidenced that the best regioselectivity (Table 7.1) was reached by generating the dianion species with NaH at 0°C and addition of (2,4,6-tri-*iso*-propylbenzene)sulfonyl chloride (TrisCl) at -78°C (entry 1). The major product **38a**, sulfonated on the position adjacent to the ethyl group, i. e. on a non-activated secondary carbon atom, has been isolated in 72% yield. The prevalent formation of this compound is due to the difference of steric hindrance in proximity of the two hydroxy groups. The mono-sulfonic ester **38a** was then cyclized to the enantiopure morpholine (+)**36** (Scheme 3). The secondary product, i.e. the enantiopure morpholine (-)**36**, on the contrary, derives from the intermediate mono-sulfonate **39**, which cyclizes as soon as it forms, through a mono-molecular mechanism promoted by the formation of a benzylic carbocation **40**. The enantiopurity of (-)**36** most likely depends on both the rigidity of the activated species and the dimension of the leaving group (LG). In fact, even if the carbocation **40** is planar, the intramolecular attack of the oxyanion proceeds only on one face, that opposite to the direction of departure of the TrisO-, which prevents with its shape the approach to the other side. As a confirm of

these hypotheses, by using TsCl (entry 4) and MsCl (entry 5) the reaction is less regioselective and the morpholine (-)36 shows a minor enantiopurity, the smaller the LG the higher the effect.

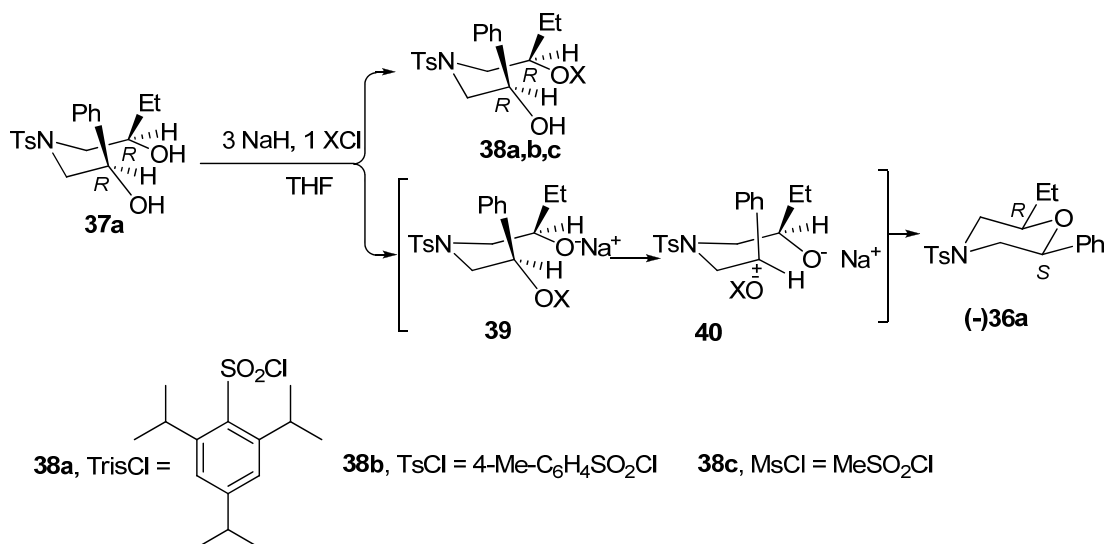

Scheme 2

Table 7.1

entry	X	T ₁ (°C) ^a	T ₂ (°C) ^b	mono-sulfonate		morpholine	
				t (h)	yield (%)	yield (%) ^c	ee (%)
1	Tris	0	-80	1.25	38a 72	(-)36a 21	98
2	Ts	-65	-65	72	38b 42	(-)36a 52	65
3	Ts	0	-80	2.5	38b 57	(-)36a 25	80
4	Ts	0	25	11	–	(+)36a 80	25 ^d
5	Ms	0	-80	4.5	38c 50	(-)36a 29	65

^a Temperature of dianion formation. ^b Temperature of the reaction with TrisCl. ^c Major enantiomer **(-) 36**. ^d Major enantiomer **(+)36**.

The monosulfonyl derivatives **38a-c** were cyclized to enantiopure morpholine **(+)36** by treating with Cs₂CO₃ under SL-PTC conditions at room temperature (Scheme 3).

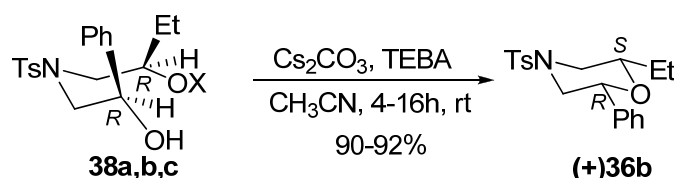

Scheme 3

Furthermore, we evaluated the coordinative interactions in the mono-*O*-sulfonylation of several representative diols **37** by using Tosylchloride. Very high yields and a complete regioselectivity of the corresponding mono-*O*-sulfonyl derivatives were reached with the diols bearing on one side arm a residue derived from ring opening of phenylglycidyl ether, and on the other side-arm a residue derived from ring opening of epoxy butane or styrene oxide (Scheme 4).

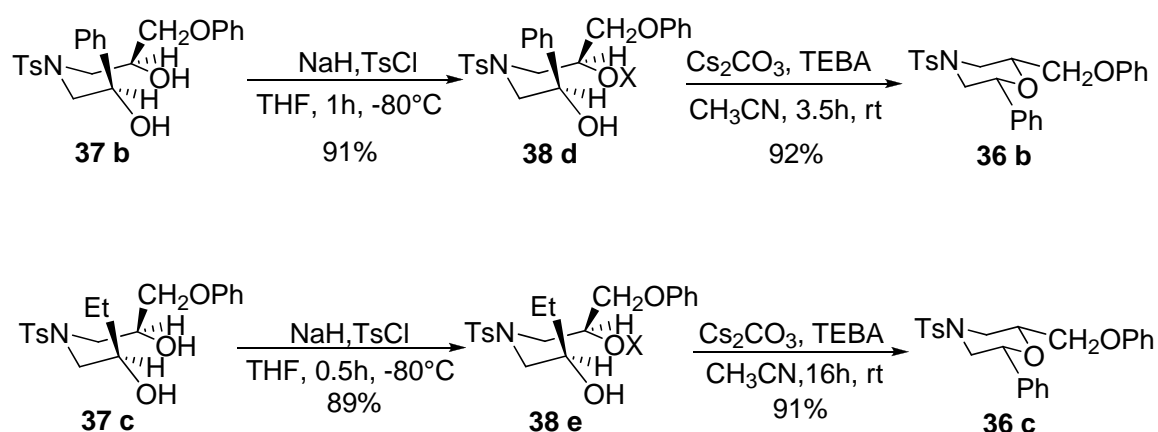

Scheme 4

The excellent regioselectivity found, suggests that the difference in reactivity arises from the different ion-pairs formed in the deprotonation step. Probably, the oxygen atom present into the glycidyl arm of diols **37**, coordinates the sodium cation, forming a 'loose ion-pair' that is much more reactive than the tight ion pair formed by the sodium cation and only one oxygen atom (Figure 7.1).

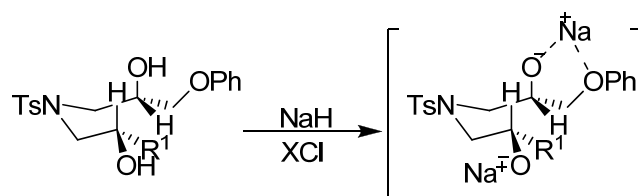

Figure 7.1

Finally, the mono-sulfonyl derivatives **38d,e** were cyclized in the presence of caesium carbonate under SL-PTC conditions, and the corresponding enantiomerically pure morpholines were isolated in very high yields.

To analyze the influence of the coordinative interaction in the reactive ion-pairs, we synthesized several amido-diols derived from consecutive ring-opening of two different oxiranes derived from glycidol, having diverse electronic distribution on their side-arms.

When compounds **37m-q** are reacted with excess NaH (Scheme nnn) basic conditions, two ion-pairs formed. As seen before, the sodium cations are coordinated by the ethereal oxygen atoms, but the electron-donating group present in one of the side-arms makes its oxygen atom more coordinating than that linked to the electron-withdrawing group.

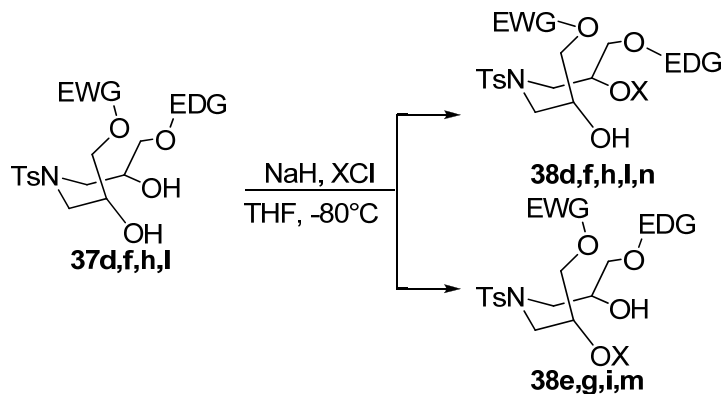

Table 7.3 Synthesis of monosulfonyl derivatives **38d-n**^a

entry	X	EDG	EWG	37	t (h)	38 (%)	EDG:EWG
1	Ts	4-MeOC ₆ H ₄	4-NO ₂ C ₆ H ₄	d	1	95	d:e 18:82
2	Ts	Ph (S)	4-NO ₂ C ₆ H ₄	f	0.5	93	f:g 22:78
3	Ts	Ph (S)	4-NO ₂ C ₆ H ₄	h	0.5	92	h:i 22:78
4	Ts	PhCH ₂ (S)	Ph (S)	l	0.5	88	l:m 27:73
5	Ts	4-MeOC ₆ H ₄	4-NO ₂ C ₆ H ₄	d ^b	1	93	d:e 18:82
6	Ts	4-MeOC ₆ H ₄	4-NO ₂ C ₆ H ₄	d ^c	8	71	d:e 50:50
7	Tris	4-MeOC ₆ H ₄	4-NO ₂ C ₆ H ₄	d	0.5	87	n 0:100

^b Reaction concentration [0.1 mol l⁻¹] instead of [0.4 mol l⁻¹]. ^c at 0°C and in presence of LiClO₄ (8 mol equiv).

The results, on the whole, indicated that the behaviour is different than that expected, i.e. the sulfonylation of the hydroxy group on the electron-rich moiety is the minor process. In fact, even though the mono-tosylation does not proceed with complete regioselectivity, a significant trend is evident: the higher the difference between the mesomeric effects induced by the substituents, the higher the regioselectivity in favour of the less coordinating moiety (entries 1-2, 4). Then, a series of experiments were carried on to evaluate the rules of this bias. The diol **37q**, which is a diastereoisomer of **37o**, was synthesized (entry 3) and then subjected to regioselective tosylation. As shown in Figure 2, in the coordination complex the dianion **37o'** bears one axial oxyanion that, in turn, forces the vicinal side-arm to assume a pseudo-axial conformation. Therefore, the phenoxy group is far from both the other side-arm and the coordinated sodium cation.

On the contrary, in the dianion **37q'**, the equatorial phenoxy group could coordinate both the Na⁺ and make more reactive the nucleophilic centre bearing the EWG function.

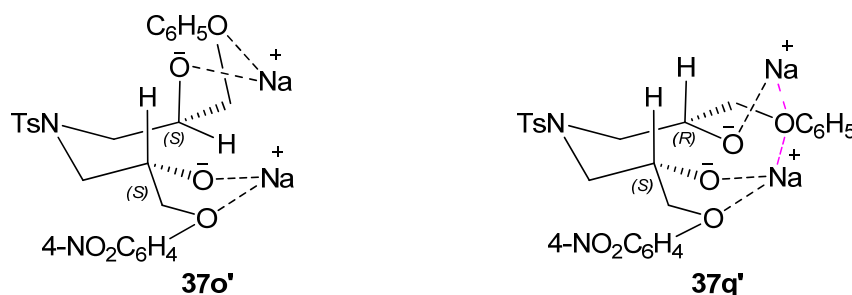

Figure 2.

The isolation of the mono-tosyl derivatives **38s,t** with identical regioisomeric ratio to that obtained by reacting diol **37o** (entry 2), indicated that the higher reactivity of the less coordinative function was independent of the substrate geometry. The presence of an aggregate was ruled out by using more diluted reaction conditions (entry 4), but analogous results to that shown before were obtained. The influence of the cation was studied adding lithium perchlorate to the reaction mixture (entry 6). The formation of two Li⁺ 'tight ion-pairs' decreases the reactivity of both the oxyanions (8 hours at 0°C) and levels the activation differences between them (**38 m,n** in ratio 50:50). Finally, by using TrisCl, **38u** was isolated as the sole regioisomer (entry 7). All these results indicate that, most likely, the EWG bearing aryloxy moiety moves the cation away from its associated anion much more than the other aryloxy group, so generating a 'loose ion-pair' more reactive and stereo-accessible, as also confirmed by the use of the hindered Tris substituent.

The difference in reactivity of 2 similar loose ion-pairs arise from the steric hindrance: probably, the electron push induced from the coordinant EDG cause a shift of the aryl moiety near the hydroxyl function, which resulted crowded. On these basis, the presence of an EWG caused a pull of the electrons and, as a consequence, the removal of the aryl moiety from the hydroxyl group, which become more accessible than the other one (Figure 3).

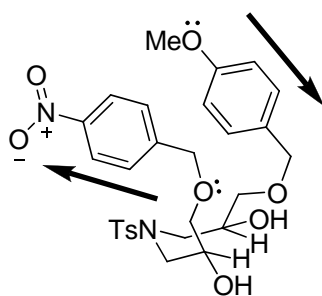
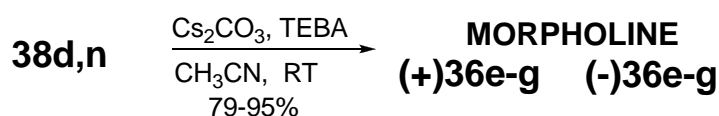
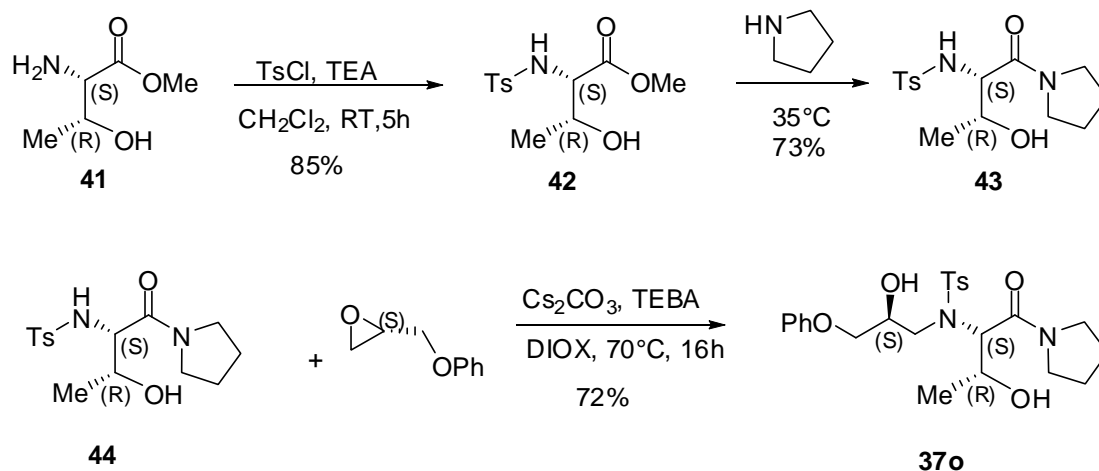

Figure 3

Even in this case, each mono sulfonyl derivative **38**, could be cyclized to the correspondent enantiopure morpholine **36f-g** under classical SL-PTC conditions with yield in a range of 78 to 95%.



This process was successfully applied to the synthesis of new, non-natural, polisubstituted morpholinyl α -amino acids, starting from natural amino acid derivatives. The reaction between tosyl-chloride and threonine methyl ester **41** gave the compound **42** that in turn was transformed into the correspondent amide **43** by reaction with pyrrolidine. Amide **43** was used as nucleophile in the usual ring-opening reaction of (S)-phenylglycidyl ether furnishing derivative **37d**; the protection of the carboxylic group as pyrrolidine amide is required to give higher stability and solubility in organic solvents (Scheme 7.2).



Scheme 7.2

Even in this case, the application of the regioselective condition to substrate **371** furnished product **381** as the sole regioisomer (Table 7.2- Entry 3). Treatment of **381** under the classical SL-PTC (Table 7.2- Entry 3) gives the 2,3,6-trisubstituted morpholine **361**. This intermediate can be easily de-tosylated under acid conditions furnishing compound **391**, a versatile precursor of a non-natural amino acid (Scheme 7.3).

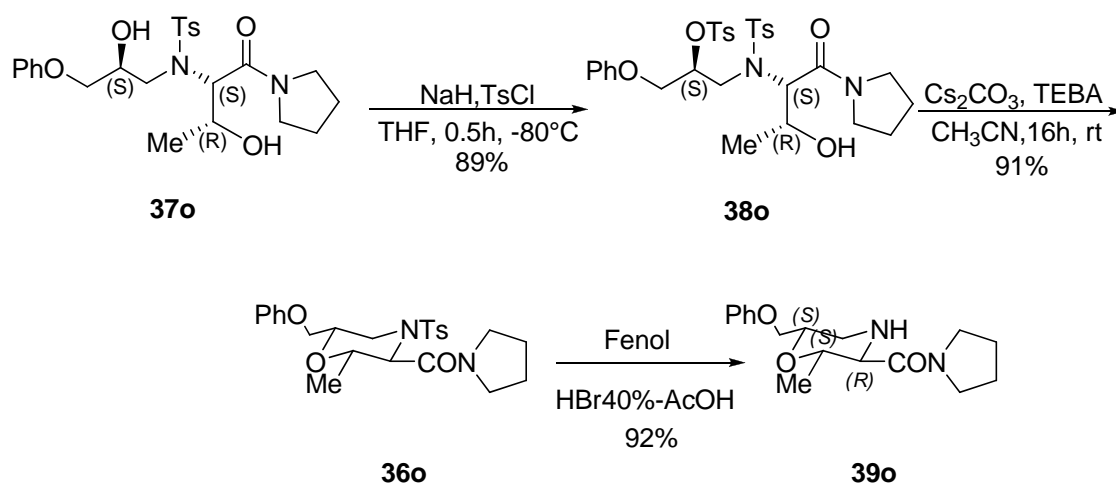

Scheme 7.3

7.2 MORPHOLINOs

Our background in the synthesis of 2,6-disubstituted-morpholines, made us focus our attention on tweaking a chemical synthesis of morpholino monomer alternative to the Summerton approach, which is the sole known synthesis. This strategy starts from the nucleoside, and the morpholine ring is formed by chemical transformation of the desoxyribose sugar rings through periodate oxidation followed by reductive amination (Scheme 7.3).

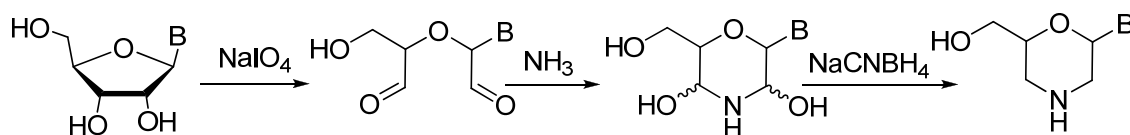

B = nucleobase

Scheme 7.4

The major limit of the process reported in Scheme 7.3 is the necessity of the use of a nucleoside: in fact, if it is true that this method is suitable for canonic nucleosides (U, A, G, C), the use of modified nucleosides causes a raise in prices. On the contrary, a chemical strategy in which the nucleic base is linked to the morpholine ring (Scheme 7.4) in the final step, could decrease the costs of the process, since a modified nucleic base is much cheaper than a modified nucleoside.

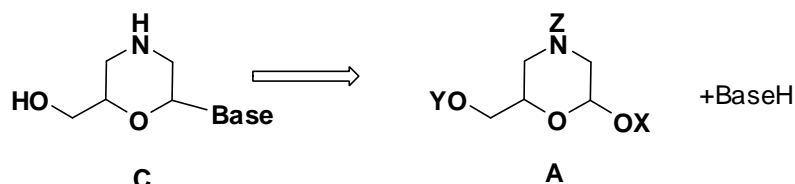

Scheme 7.5

Compound C (Scheme 7.5) could be synthesized by condensation of a generic intermediate A and a nucleic base in presence of a Lewis acid, using pseudo-sugar chemistry.

In this contest, the synthesis of model compound **44a** (Scheme 7.6) started with a simple nucleophilic reaction between bromoacetaldehyde di-ethyl acetal **40**, and tosylamide under SL-PTC conditions (Step-i). The amido alcohol **42a** was prepared through nucleophilic ring opening of benzylglycidyl ether by intermediate **41** under classical SL-PTC conditions (Step-ii). We chose the epoxide reported in Scheme 7.6 since the benzylic function can be easily removed.

Deprotection of the aldehyde moiety was carried out under acid conditions, in presence of *para*-toluensulfonic acid; compound **43a** was obtained as an anomeric mixture in a

fairly good yield (Step-iii). Then, in order to convert the hydroxylic function in a more activated species; the diastomeric mixture of **43a**, was treated with benzoyl chloride under basic homogenous conditions, affording **44a** in 94% yield (Step-iv).

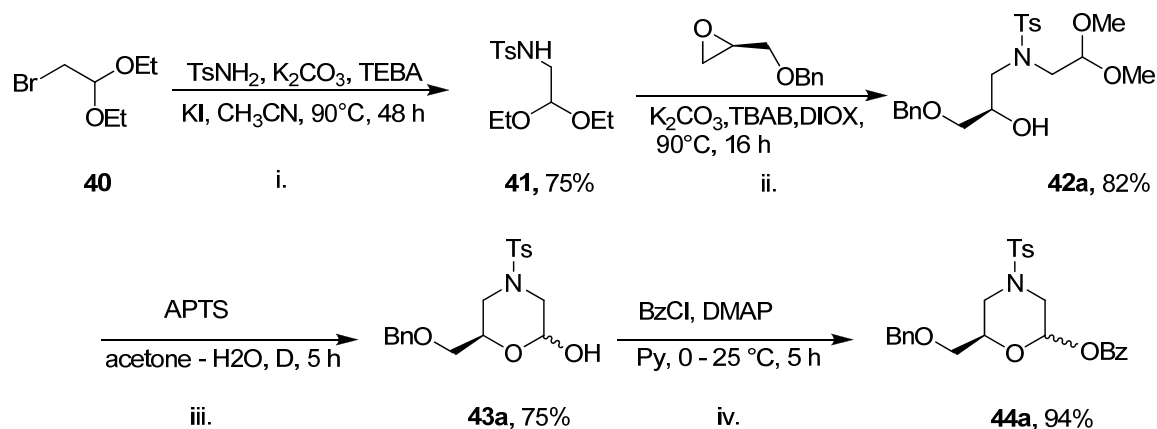

Scheme 7.6

Initial studies, involving the treatment of intermediates **44a** under the action of several Lewis acids, in presence of adenine as model nucleic base, led to the formation of the bicycle **45** as the sole product (Scheme 7.7). Compound **45** derives from the intramolecular attack by the hydroxylic function, which results from the deprotection of the benzylic function, promoted by the Lewis acid. Compound **45**, in turn, was stable in presence of Lewis-acids and, the related morpholine was not formed, even in traces.

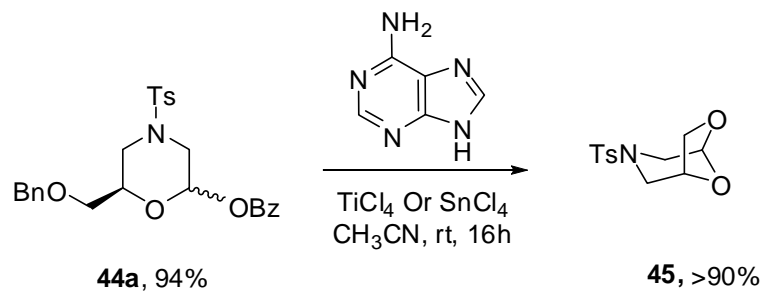

Scheme 7.7

A novel protecting group for the alcoholic function on the side arm was chosen: we synthesized the amido alcohol **42b**, in which the benzylic function (Scheme 7.6, **42a**) was changed into a benzoyl group (Scheme 7.8). As above described, the application of deprotection/ring closure reaction (Step-iii, Scheme 7.6) followed by *O*-benzoylation (Scheme 7.6), furnished morpholine **44b** (Scheme 7.8).

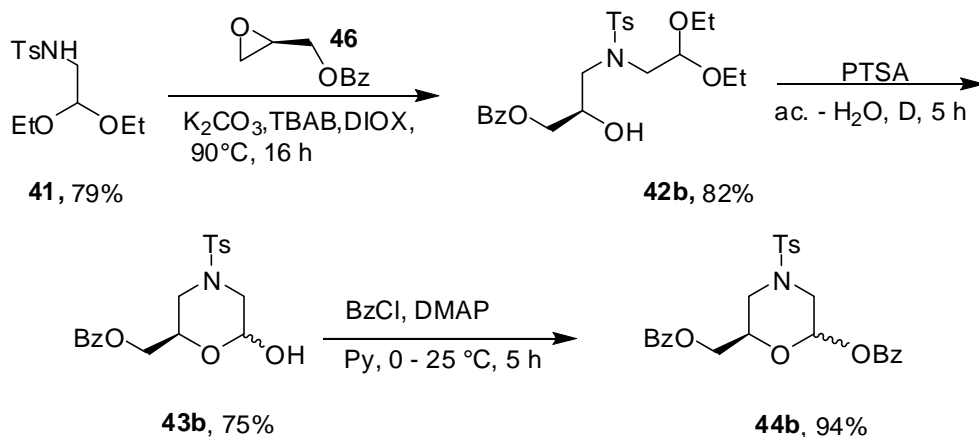

Scheme 7.8

Then, we performed the key Lewis-acid promoted addition of the nucleic base on the anomeric mixture of **44b** (α : β -1:2.5): preliminary runs conducted using Tin (IV) chloride as Lewis acid, evidenced that the use of CH_3CN is essential for the reaction progress (entry 1, Table 7.3). Treatment of a CH_3CN solution of compound **44b** with adenine as a nucleophile gave a suspension which became homogeneous during the addition of the Lewis acid. When a solvent different from CH_3CN was used, we did not observe the dissolution of the nucleobase. Under these conditions (entry 1), we isolated **47a** as the major anomer (49%) together with **47b** (18%). Furthermore, the use of the adeninate derivative N-CBZ slightly increased the reaction yield but dramatically decreased the diastereoselectivity (entry 4).

On the contrary, changing the Lewis acid, morpholino **47b** was isolated as the major anomer (entry 5-6). In particular, using trimethylsilyl(IV) trifluoromethanesulfonate (TMSOTf) the derivatives **47a** was isolated with the best yield and diastereoselectivity (Entry 6).

Very poor or no results were obtained with the less hard or borderline Lewis acids (entry 7-11); interestingly, we isolated the hydroxyl morpholine **43b** as a by-product when Sn (II) or Zr (IV) were used.

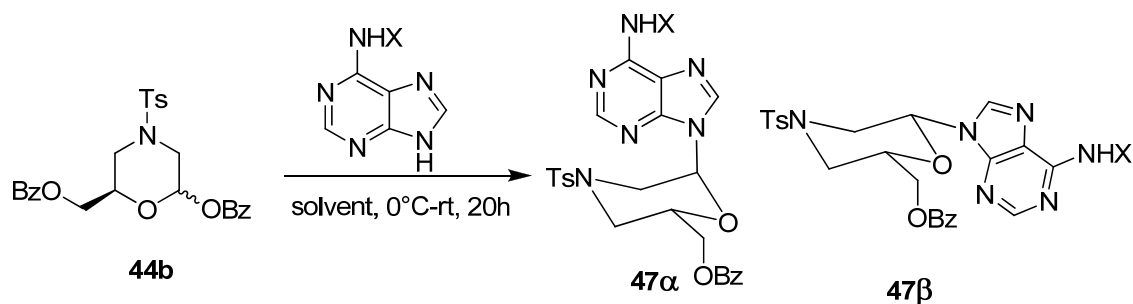
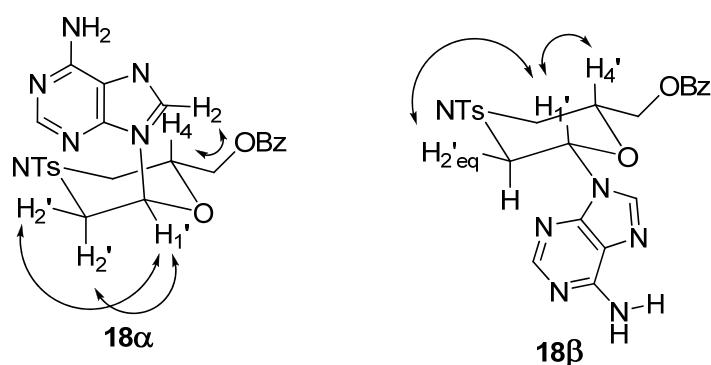

Table 7.3

Entry	X	Lewis Acid	solvent	47%	$\alpha:\beta$
1	H	SnCl ₄	CH ₃ CN	67	72:28
2	H	SnCl ₄	DCE	trax	--
3	H	SnCl ₄	p-Xilene	trax	--
4	CBZ	SnCl ₄	CH ₃ CN	73	56:44
5	H	TiCl ₄	CH ₃ CN	72	33:67
6	H	TMSTF	CH ₃ CN	75	30:70
7	H	InCl ₃	CH ₃ CN	--	--
8	H	NbCl	CH ₃ CN	--	--
9	H	ZrCl ₄	CH ₃ CN	22	--
10	H	SnCl ₂	CH ₃ CN	15	--
11	H	Ti(<i>i</i> -PrO) ₄	CH ₃ CN	--	--

The relative stereochemistry of the two diastereomers α and β , was deduced from both their vicinal coupling constants between H-2' and H-3' ($J_{2',3'}^{\text{ax,eq}} = 2.1, 3.3$ Hz for the alpha anomer and 2.4, 12.3 Hz for the beta) and Noesy analysis. The Noesy spectra of the alpha anomer showed the Noesy cross peaks between H-2' and both the 2 hydrogens H_{3'}; this experiment has also evidenced an interestingly correlation between H_{4'} and H₂. The beta anomer exhibited the classical Noesy cross peak between the anomeric proton H_{2'} and H_{4'} and another between H_{2'} and H_{3'} in equatorial position.



Scheme 7.9

In order to improve the overall yield of morpholine subunit **44** we applied the classical SL-PTC condition to the ring opening of glycidol, since this ring opening is easier than that of an epoxide bearing a carboxylic moiety. In addition, it is well known that acylation reactions occur on primary hydroxylic function, in the presence of either an additional secondary or tertiary hydroxy group.

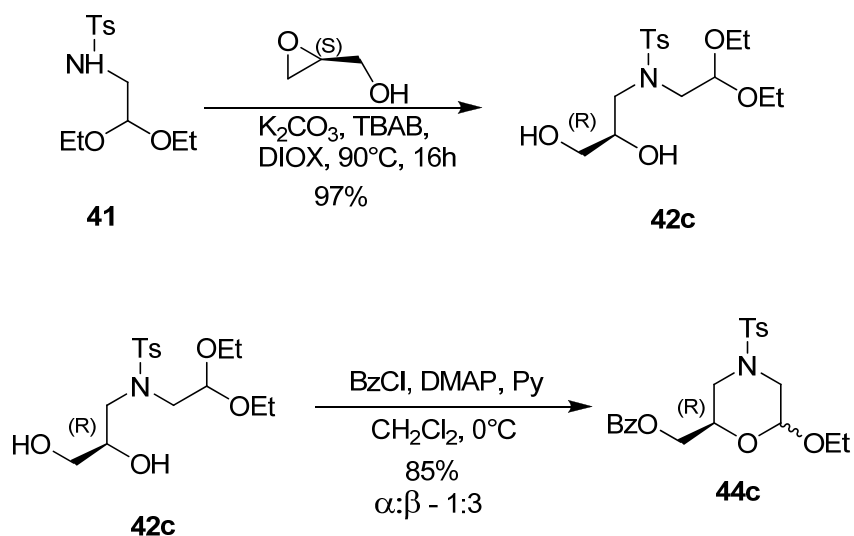

Scheme 7.10

The glycidol ring opening using the *N*-tosylamido derivative **41** gave quantitative yield of the expected diol **42c**, whereas treatment of compound **42c** under benzoylation conditions did not lead to the expected mono benzoyl derivative **42b**, but it gives the *O*-ethyl-morpholine **44c** as the sole reaction product in an anomeric ratio $\alpha:\beta$ -1:3 (Scheme 7.10). Further investigations, conducted on the benzoylation reaction (Scheme 7.9), indicate that the reaction is an acid-promoted cyclization. In fact, the morpholine formation was observed only when to the mixture of diol **42c** in presence of a weak base like pyridine (pH 10) benzoyl chloride was added, and the environment becomes acidic (pH = 1).

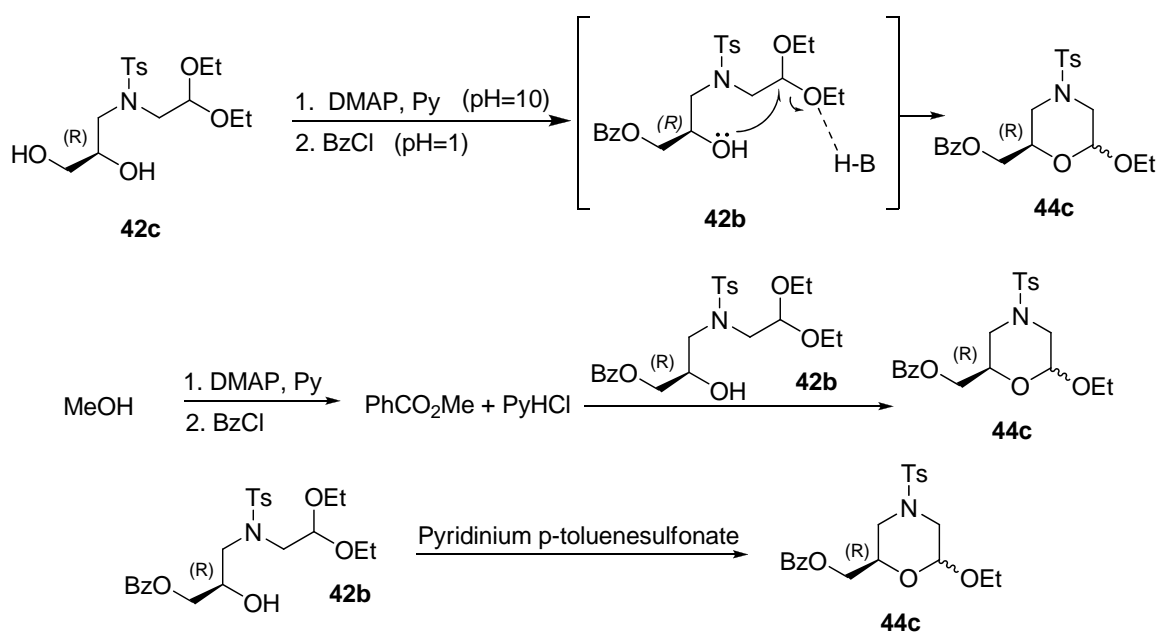

Scheme 7.11

We confirmed this hypothesis by forming the methyl benzoate treating methanol in presence of pyridine and benzoyl chloride. The addition of the mono benzoyl derivative **42b** furnished the expected morpholine **44c** (Scheme 7.11). In addition, treatment of mono benzoyl derivative **42b** in presence of pyridinium *para*-toluensulfonate furnished, even in this case morpholine **44c** (Scheme 7.11).

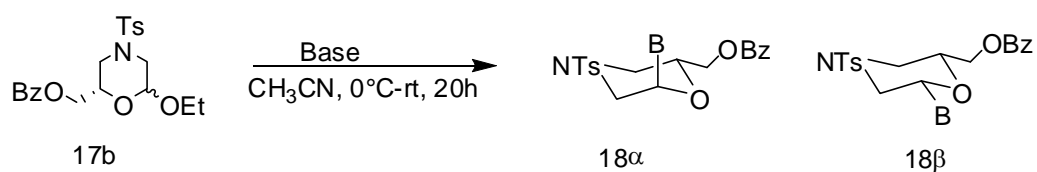

Table 7.4

Entry	NucleoBase	Lewis Acid	solvent	18%	$\alpha:\beta$
1	Adenine	SnCl ₄	CH ₃ CN	72	85:15
2	Adenine	SnCl ₄	DCE	< 5	--
3	Adenine	TMSOTf	CH ₃ CN	75	30:70
4	F-Uracile	SnCl ₄	CH ₃ CN	84	0:100
5	F-Uracile	TMSOTf	CH ₃ CN	91	5:95
6	Timine	SnCl ₄	CH ₃ CN	81	0:100
7	Timine	TMSOTf	CH ₃ CN	87	5:95

8- SPERIMENTAL SECTION

Materials and Methods

All reactions were carried out in flame-dried glassware with magnetic stirring. Isolated yields refer to homogeneous materials (TLC, HPLC, NMR). Reagent-grade commercially available reagents and solvents were used; anhydrous solvents were used as purchased. TLC was performed using 0.25 mm silica-gel pre-coated plates and visualized by UV-254 light and CAM staining. Silica-gel (particle size 0.040–0.063 mm) was used for flash column chromatography (FCC) and medium pressure liquid chromatographic (MPLC). Melting points are corrected. Chiral HPLC analyses were performed using CHIRALCEL OJ-H (250/4.6) columns. IR spectra are reported in frequency of absorption (cm^{-1}). $[\alpha]_D$'s were measured at 589 nm, using a (10 cm X 5 mL) cell and c is in g/100 mL. NMR spectra were recorded at: 300.13 MHz for ^1H and 75.00 MHz for ^{13}C ; TMS was used as external reference; δ are in ppm and J are in Hz.

General Procedure for the Synthesis of (4-Aryl)sulfonamides 4a-j, 9.

To a suspension of L-proline *tert*-butyl ester (1.71 g, 10 mmol) in dry dichloromethane (40 mL), DIPEA (1.88 mL, 11 mmol) was added at 25 °C. After cooling at 0 °C, sulfonyl chloride (10 mmol) was added dropwise and the resulting solution was stirred until no starting material was detectable by TLC. The solution was then diluted with dichloromethane (20 mL), washed with saturated NH₄Cl solution (2×15 mL), saturated NaHCO₃ solution (2×15 mL), and brine (20 mL), dried over MgSO₄ and filtered. After evaporation of the solvent under vacuum (RV), the crude was purified by FCC to afford sulfonamides **1a-e**. Yields, chromatographic eluants, physical and analytical data are as follows.

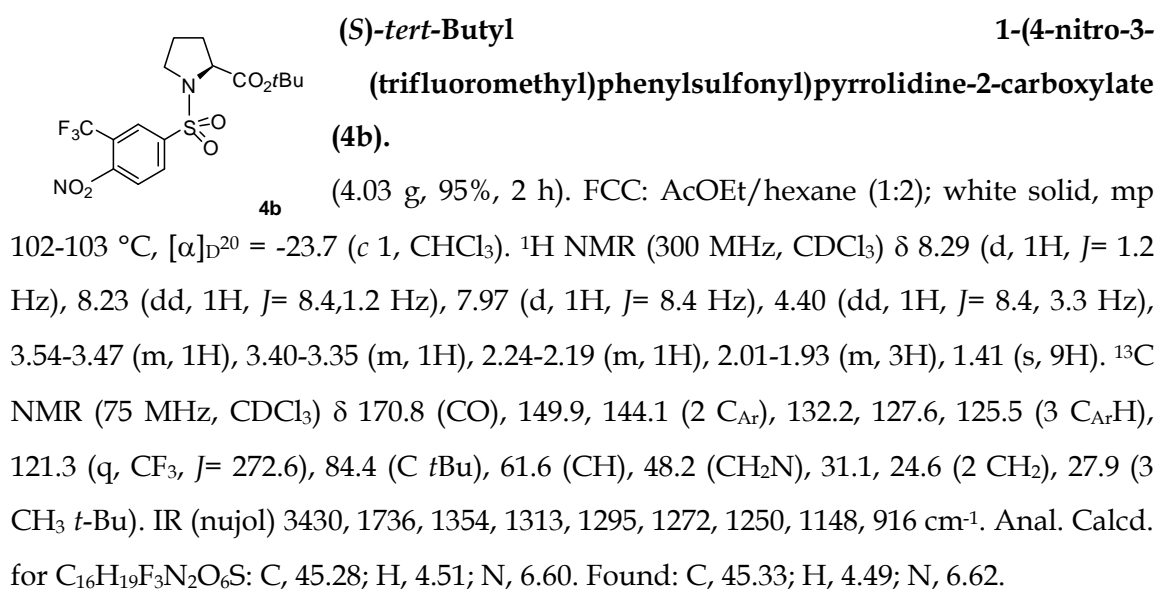
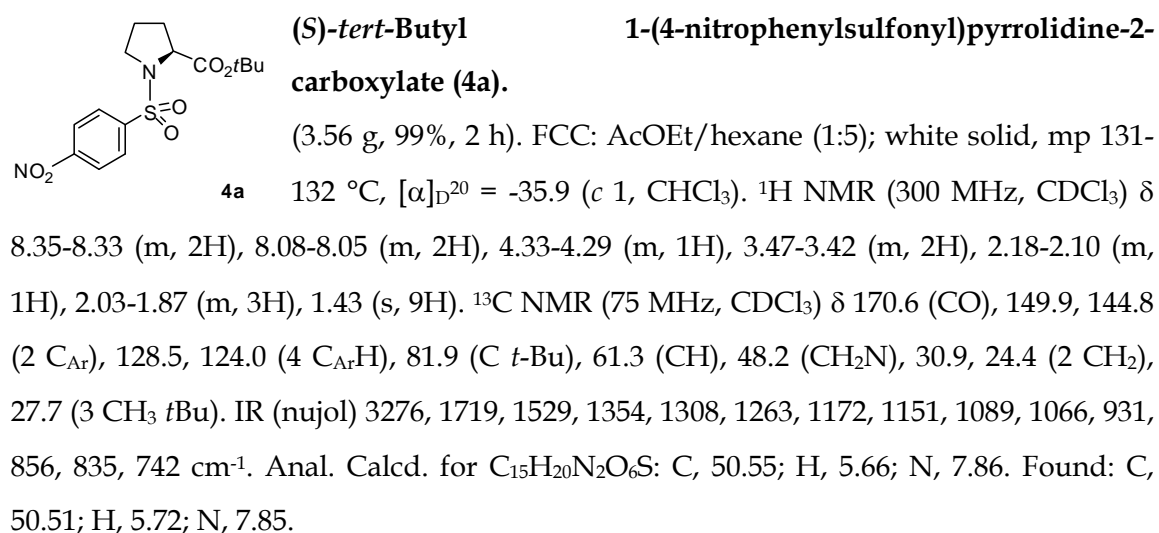

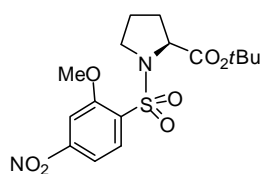

(S)-tert-Butyl 1-(2-methoxy-4-nitrophenylsulfonyl)pyrrolidine-2-carboxylate (4c).

(3.71 g, 96%, 2 h); FCC - AcOEt/hexane (1:5); colour less wax, $[\alpha]_{\text{D}}^{20}$ = -20.2 (c 0.7, CHCl₃). ¹H NMR (300 MHz, CDCl₃) δ 8.07 (d, 1H, J=

9.0), 7.84-7.81 (m, 2H), 4.39 (dd, 1H, J= 8.4, 3.0 Hz), 4.05 (s, 3H) 3.66-3.59 (m, 1H), 3.51-3.44 (m, 1H), 2.19-1.83 (m, 4H), 1.35 (s, 9H). ¹³C NMR (75 MHz, CDCl₃) δ 170.8 (CO), 157.2, 151.0, 133.9 (3 C_{Ar}), 131.9, 114.8, 107.2 (3 C_{Ar}H), 81.4 (C *t*-Bu), 61.3, 56.7 (CH, CH₃), 48.4 (CH₂N), 30.9, 24.4 (2 CH₂), 27.6 (3 CH₃ *t*Bu). IR (nujol) 3343, 3114, 1732, 1524, 1408, 1338, 1252, 915, 742 cm⁻¹. Anal. Calcd. for C₁₆H₂₂N₂O₇S: C, 49.73; H, 5.74; N, 7.25. Found: C, 49.75; H, 5.78; N, 7.21.

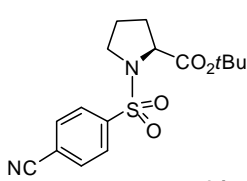

(S)-tert-Butyl 1-(4-cyanophenylsulfonyl)pyrrolidine-2-carboxylate (4d).

(3.13 g, 93%, 2 h). FCC: AcOEt/hexane (1:5); white solid, mp 111-113 °C, $[\alpha]_{\text{D}}^{20}$ = -50.9 (c 0.8, CHCl₃). ¹H NMR (300 MHz, CDCl₃) δ

7.99-7.96 (m, 2H), 7.79-7.77 (m, 2H), 4.27 (dd, 1H, J= 8.4, 3.3 Hz), 3.41-3.37 (m, 2H), 2.18-2.04 (m, 1H), 1.99-1.82 (m, 3H), 1.40 (s, 9H). ¹³C NMR (75 MHz, CDCl₃) δ 171.3 (CO), 143.9, 117.9, 116.7 (2 C_{Ar}, CN), 133.2, 128.5 (4 C_{Ar}H), 82.4 (C *t*-Bu), 61.8 (CH), 48.7 (CH₂N), 30.4, 25.0 (2 CH₂), 28.3 (3 CH₃ *t*Bu). IR (nujol) 3421, 2226, 1742, 1459, 1350, 1308, 1159, 636 cm⁻¹. Anal. Calcd. for C₁₆H₂₀N₂O₄S: C, 57.12; H, 5.99; N, 8.33. Found: C, 57.12; H, 5.95; N, 8.29.

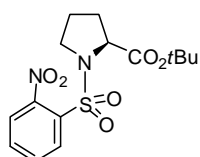

(S)-tert-Butyl 1-(2-nitrophenylsulfonyl)pyrrolidine-2-carboxylate (4e).

(3.03 g, 85%, 2 h). FCC: AcOEt/hexane (1:2); white solid, mp 117-118 °C, $[\alpha]_{\text{D}}^{20}$ = -96.5 (c 1, CHCl₃). ¹H NMR (300 MHz, CDCl₃) δ 8.17-8.14

(m, 1H), 7.72-7.67 (m, 3H), 4.50 (dd, 1H, J= 8.2, 2.6 Hz), 3.71-3.64 (m, 1H), 3.63-3.55 (m, 1H), 2.34-2.22 (m, 1H), 2.13-1.96 (m, 3H), 1.45 (s, 9H). ¹³C NMR (75 MHz, CDCl₃) δ 170.9 (CO), 157.6, 148.1 (2 C_{Ar}), 133.3, 131.6, 131.1, 124.0 (4 C_{Ar}H), 81.9 (C *t*Bu), 61.8 (CH), 48.4 (CH₂N), 31.1, 24.4 (2 CH₂), 27.9 (3 CH₃ *t*Bu). IR (nujol) 3276, 1719, 1529, 1354, 1308, 1263, 1172, 1151, 1089, 1066, 931, 856, 835, 742 cm⁻¹. Anal. Calcd. for C₁₅H₂₀N₂O₆S: C, 50.55; H, 5.66; N, 7.86. Found: C, 50.53; H, 5.70; N, 7.82.

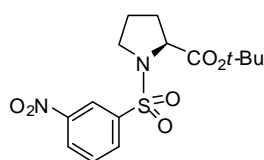

(S)-tert-butyl 1-(3-nitrophenylsulfonyl)pyrrolidine-2-carboxylate (4j).

(3.17 g, 89%, 2h); FCC - AcOEt/hexane (1 : 3); yellow wax, $[\alpha]_{\text{D}}^{20} = -72.8$ (*c* 0.7, CHCl₃). ¹H NMR (300 MHz, CDCl₃) δ 8.68-8.67 (m, 1H), 8.43-8.38 (m, 1H), 8.22-8.17 (m, 1H), 7.76-7.68 (m, 1H), 4.33 (dd, 1H, *J* = 7.4, 2.6), 3.47-3.40 (m, 2H), 2.00-1.89 (m, 4H), 1.42 (s, 9H). ¹³C NMR (75 MHz, CDCl₃) δ 170.9 (CO), 148.2, 141.5 (2 C_{Ar}), 133.0, 130.2, 127.0, 122.7 (4 C_{Ar}H), 82.1 (C *t*-Bu), 61.4 (CH), 48.2 (CH₂N), 31.1, 24.6 (2 CH₂), 27.9 (3 CH₃ *t*-Bu). Anal. Calcd. for C₁₅H₂₀N₂O₆S: C, 50.55; H, 5.66; N, 7.86. Found: C, 50.48; H, 5.51; N, 7.93.

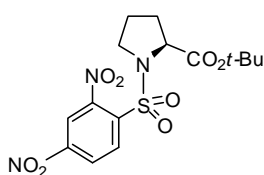

(S)-tert-butyl 1-(2,4-dinitrophenylsulfonyl)pyrrolidine-2-carboxylate (4g).

(3.93 g, 98%, 2h); FCC - AcOEt/hexane (1 : 5); yellow solid, mp 100.0-100.8°C, $[\alpha]_{\text{D}}^{20} = -68.6$ (*c* 1, CHCl₃). ¹H NMR (300 MHz, CDCl₃) δ 8.45-8.43 (m, 2H), 8.33-8.30 (m, 1H), 4.49 (dd, 1H, *J* = 8.1, 2.7), 3.64-3.60 (m, 2H), 2.35-2.10 (m, 1H), 2.01-1.95 (m, 3H), 1.40 (s, 9H). ¹³C NMR (75 MHz, CDCl₃) δ 170.5 (CO), 149.5, 148.1, 138.7 (3 C_{Ar}), 132.8, 125.9, 119.4 (3 C_{Ar}H), 82.4 (C *t*-Bu), 62.0 (CH), 48.9 (CH₂N), 31.1, 24.4 (2 CH₂), 27.8 (3 CH₃ *t*-Bu). Anal. Calcd. for C₁₅H₁₉N₃O₈S: C, 44.88; H, 4.77; N, 10.47. Found: Found: C, 44.80; H, 4.84; N, 10.40.

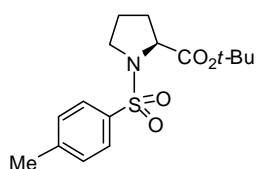

(S)-tert-butyl 1-tosylpyrrolidine-2-carboxylate (4h).

(3.05 g, 94%, 2h); FCC - AcOEt/hexane (1 : 3); white solid, mp 95.9-97.0°C, $[\alpha]_{\text{D}}^{20} = -107.0$ (*c* 1, CHCl₃). ¹H NMR (300 MHz, CDCl₃) δ 7.74-7.71 (m, 2H), 7.28-7.25 (m, 2H), 4.14 (dd, 1H, *J* = 6.9, 2.4), 3.47-3.40 (m, 1H), 3.32-3.25 (m, 1H), 2.38 (s, 3H), 1.98-1.88 (m, 3H), 1.73-1.69 (m, 1H), 1.41 (s, 9H). ¹³C NMR (75 MHz, CDCl₃) δ 171.2 (CO), 143.3, 135.8 (2 C_{Ar}), 129.6, 127.4 (4 C_{Ar}H), 81.5 (C *t*-Bu), 61.2 (CH), 48.3 (CH₂N), 30.9, 24.5 (2 CH₂), 27.9 (3 CH₃ *t*-Bu), 24.5 (1 CH₃). Anal. Calcd. for C₁₆H₂₃NO₄S: C, 59.05; H, 7.12; N, 4.30. Found Found: C, 59.12; H, 7.06; N, 4.40.

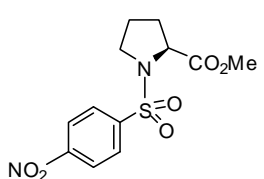

(S)-Methyl 1-(4-nitrophenylsulfonyl)pyrrolidine-2-carboxylate (9).

9

(3.53 g, 89%, 2 h). FCC: AcOEt/hexane (1:4); white solid, mp 125-128 °C, $[\alpha]_{\text{D}}^{20} = -69.0$ (c 1.3, CHCl_3). ^1H NMR (300 MHz, CDCl_3) δ 8.39-8.34 (m, 2H), 8.09-8.05 (m, 2H), 4.46 (dd, 1H, $J=12.0, 3.7$ Hz), 3.70 (s, 3H), 3.45 (m, 2H), 2.23-1.86 (m, 3H). ^{13}C NMR (75 MHz, CDCl_3) δ 171.8 (CO), 149.9, 144.3 (2 C_{Ar}), 128.4, 124.0 (4 $\text{C}_{\text{Ar-H}}$), 60.4, 52.2 (CH, CH_3), 48.2 (CH_2N), 30.7, 24.4 (2 CH_2). IR (nujol) 3279, 1709, 1541, 1350, 1323, 1256, 1172, 1139, 1075, 931, 754 cm^{-1} . Anal. Calcd. for $\text{C}_{12}\text{H}_{14}\text{N}_2\text{O}_6\text{S}$: C, 45.85; H, 4.49; N, 8.91. Found: C, 45.89; H, 4.43; N, 8.92.

General Procedure for the Rearrangement of 4a-e to (4-Aryl)sulfonamides 5a-e, 10.

In a flame-dried round bottomed flask cooled at 0 °C, to a suspension of 95% sodium amide (or 60% sodium hydride, previously washed three times with pentane) (2.5 mmol) in anhydrous *N,N*-dimethylacetamide (1.5 mL), a solution of sulfonamido ester **1** (1 mmol) in anhydrous *N,N*-dimethylacetamide (4.5 mL) was added under nitrogen atmosphere. The resulting solution was stirred at 0 °C until the reaction was complete (TLC), then was quenched with saturated NH₄Cl solution. After extraction with ethyl acetate and evaporation under reduced pressure, the crude was purified by FCC on silica gel. Starting materials, yields, reaction times, chromatographic eluants, physical, spectroscopic, and analytical data are as follows.

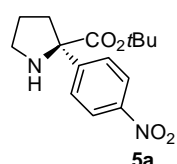

(*R*)-*tert*-Butyl 2-(4-nitrophenyl)pyrrolidine-2-carboxylate (**5a**).

Sulfonamide **4a**, 356 mg; **5a** (263 mg, 90%, 15 min). FCC: AcOEt/hexane (1:4); clear wax, $[\alpha]_D^{20} = -36.6$ (*c* 0.8, CHCl₃), *ee* 94% [CHIRALCEL OJ-H, hexane/*i*PrOH (95:5), flow rate 1 mL/min, P 26 bar, *t*₁ 9.639, *t*₂ 11.384]. ¹H NMR (300 MHz, (CD₃)₂CO) δ 8.39-8.35 (m, 2H), 7.82-7.79 (m, 2H), 3.62-3.44 (m, 2H), 3.04-2.95 (m, 1H), 2.61-2.50 (m, 1H), 2.39-2.23 (m, 1H), 2.17-2.04 (m, 1H), 1.43 (s, 9H). ¹³C NMR (75 MHz, (CD₃)₂CO) δ 168.1 (CO), 148.3, 141.6 (2 C_{Ar}), 127.6, 123.7 (4 C_{Ar}H), 85.2, 74.2 (2 C), 44.7 (CH₂N), 33.3, 21.8 (2 CH₂), 26.2 (3 CH₃ *t*Bu). IR (nujol) 3276, 1720, 1519, 1461, 960, 863 cm⁻¹. Anal. Calcd. for C₁₅H₂₀N₂O₄: C, 61.63; H, 6.90; N, 9.58. Found: C, 61.66; H, 6.87; N, 9.63.

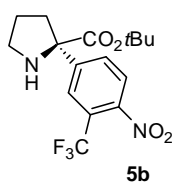

(*R*)-*tert*-Butyl 2-(4-nitro-3-(trifluoromethyl)phenyl)pyrrolidine-2-carboxylate (**5b**).

Sulfonamide **4b**, 424 mg; **5b** (231 mg, 64 %, 20 min). FCC: AcOEt/hexane (1:3); yellow wax, $[\alpha]_D = -32.2$ (*c* 1, CHCl₃) *ee* 94% [CHIRALCEL OJ-H, hexane/*i*PrOH (95:5), flow rate 1 mL/min, P 26 bar, *t*₁ 4.928, *t*₂ 9.554]. ¹H NMR (300 MHz, CDCl₃) δ 8.10 (d, 1H, *J* = 1.5 Hz), 7.98 (dd, 1H, *J* = 8.7, 1.5 Hz), 7.8 (d, 1H, *J* = 8.7 Hz), 3.19-3.11 (m, 1H), 3.05-2.97 (m, 1H), 2.87 (bs, 1H), 2.69-2.61 (m, 1H), 2.05-1.96 (m, 1H), 1.84-1.75 (m, 2H), 1.40 (s, 9H). ¹³C NMR (75 MHz, CDCl₃) δ 172.9 (CO), 149.7 146.8, 131.5 (3 C_{Ar}), 131.1, 126.5, 124.7 (3 C_{Ar}H), 121.7 (q, CF₃, *J* = 271.7 Hz), 83.0, 72.4 (2 C), 46.3 (CH₂N), 38.7, 25.4 (2 CH₂), 27.7 (3 CH₃ *t*Bu). IR (nujol) 3385,

1737, 1643, 1520, 728, 701. Anal. Calcd. for C₁₆H₁₉F₃N₂O₄: C, 53.33; H, 5.31; N, 7.77. Found: C, 53.32; H, 5.25; N, 7.81.

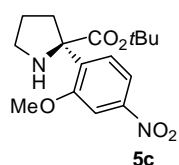

(R)-tert-Butyl 2-(2-methoxy-4-nitrophenyl)pyrrolidine-2-carboxylate (5c)

Sulfonamide **4c**, 424 mg; **5c** (206 mg, 64 %, 24 h). FCC: AcOEt/hexane (1:3); yellow wax, $[\alpha]_{\text{D}}^{20} = -22.1$ (c 1, CHCl₃) *ee* 91% [CHIRALCEL OJ-H, hexane/*i*PrOH (95:5), flow rate 1 mL/min, P 34 bar, *t*₁ 9.318, *t*₂ 11.920]. ¹H NMR (300 MHz, CDCl₃) δ 7.82 (dd, 1H, *J* = 8.4, 2.1 Hz), 7.80 (d, 1H, *J* = 8.4 Hz), 7.65 (d, 1H, *J* = 2.1 Hz), 3.87 (s, 3H), 3.22-3.06 (m, 2H), 2.76 (bs, 1H), 2.62-2.53 (m, 1H), 2.05-1.88 (m, 3H), 1.33 (s, 9H). ¹³C NMR (75 MHz, CDCl₃) δ 173.2 (CO), 157.0, 148.0, 140.1 (3 C_{Ar}), 126.4, 115.7, 105.2 (3 C_{Ar}H), 81.1, 69.9 (2 C), 55.6 (CH₃), 45.6 (CH₂N), 34.2, 24.3 (2 CH₂), 27.7 (3 CH₃ *t*Bu). IR (nujol) 3400, 1730, 1594, 1523, 1250, 1157, 803, 741 cm⁻¹. Anal. Calcd. for C₁₆H₂₂N₂O₅: C, 59.61 H, 6.88; N, 8.69. Found: C, 59.58; H, 6.92; N, 8.71.

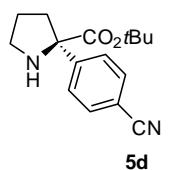

(R)-tert-Butyl 2-(4-cyanophenyl)pyrrolidine-2-carboxylate (5d).

Sulfonamide **4d**, 336 mg; **5d** (166 mg, 61%, 20 min). FCC: AcOEt/hexane (1:3); yellow wax, $[\alpha]_{\text{D}}^{20} = -24.3$ (c 0.8, CHCl₃) *ee* 96% [CHIRALCEL OJ-H, hexane/*i*PrOH (95:5), flow rate 0.7 mL/min, P 26 bar, *t*₁ 9.484, *t*₂ 10.740]. ¹H NMR (300 MHz, CDCl₃) δ 7.69-7.66 (m, 2H), 7.59-7.57 (m, 2H), 3.14-2.97 (m, 2H), 2.70-2.61 (bs+m, 2H), 2.02-1.93 (m, 1H), 1.84-1.76 (m, 2H), 1.37 (s, 9H). ¹³C NMR (75 MHz, CDCl₃) δ 173.6 (CO), 148.9, 118.9, 110.8 (2C_{Ar}, CN), 131.8, 127.1 (4 C_{Ar}H), 82.2, 72.6 (2 C), 45.9 (CH₂N), 37.3, 25.0 (2 CH₂), 27.7 (3 CH₃ *t*Bu). IR (nujol) 3430, 2227, 1721, 1630, 1499, 845, 715 cm⁻¹. Anal. Calcd. for C₁₆H₂₀N₂O₂: C, 70.56; H, 7.40; N, 10.29. Found: C, 70.52; H, 7.35; N, 10.23.

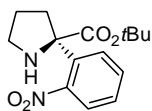

(R)-tert-Butyl 2-(2-nitrophenyl)pyrrolidine-2-carboxylate (5e).

Sulfonamide **4e**, 356 mg; **5e** (158 mg, 54%, 20 min). FCC: AcOEt/hexane (1:2); clear wax, $[\alpha]_{\text{D}}^{20} = -5.5$ (c 1, CHCl₃) *ee* 94% [CHIRALCEL OJ-H, hexane/*i*PrOH (95:5), flow rate 1 mL/min, P 34 bar, *t*₁ 26.018, *t*₂ 28.853]. ¹H NMR (300 MHz, CDCl₃) δ 7.72-7.70 (m, 1H), 7.61-7.51 (m, 3H), 3.91-3.83 (m, 1H), 3.49-3.41 (m, 1H), 2.80-2.72 (m, 1H), 2.13-1.97 (m, 1H), 1.90-1.82 (m, 3H), 1.43 (s, 9H). ¹³C NMR (75 MHz, CDCl₃) δ 169.2 (CO), 138.4, 135.8 (2 C_{Ar}), 133.1, 130.0, 124.4, 121.3 (4 C_{Ar}H), 83.2, 71.1 (2 C), 48.7 (CH₂N), 37.3, 26.2 (2 CH₂), 27.7 (3 CH₃ *t*Bu). IR (nujol) 3391,

1727, 1524, 1455, 957, 860, 735 cm⁻¹. Anal. Calcd. for C₁₅H₂₀N₂O₄: C, 61.63; H, 6.90; N, 9.58. Found: C, 61.59; H, 6.87; N, 9.56.

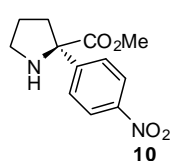

(R)-Methyl 2-(4-nitrophenyl)pyrrolidine-2-carboxylate (10)

Sulfonamide **9**, 314 mg; **10** (121 mg, 48%, 30 min). FCC: AcOEt/hexane (1:3); clear wax, $[\alpha]_{\text{D}}^{20} = -7.0$ (*c* 1, CHCl₃), *ee* 78% [CHIRALCEL OJ-H, hexane/*i*PrOH (95:5), flow rate 1 mL/min, P 17 bar, *t*₁ 15.108, *t*₂ 17.125]. ¹H NMR (300 MHz, CDCl₃) δ 8.17-8.14 (m, 2H), 7.76-7.74 (m, 2H), 3.70 (s, 3H), 3.18-3.03 (m, 2H), 2.88 (bs, 1H), 2.79-2.71 (m, 1H), 2.10-1.97 (m, 1H), 1.88-1.76 (m, 2H). ¹³C NMR (75 MHz, CDCl₃) δ 174.8 (CO), 150.2, 147.2 (2 C_{Ar}), 127.4, 123.3 (4 C_{Ar}H), 72.2 (C), 53.1 (CH₃), 46.0 (CH₂N), 37.6, 25.0 (2 CH₂). IR (nujol) 3203, 1780, 1502, 1453, 962 cm⁻¹. Anal. Calcd. for C₁₂H₁₄N₂O₄: C, 57.59; H, 5.64; N, 11.19. Found: C, 57.53; H, 5.61; N, 11.22.

Synthesis of (R)-2-(4-nitrophenyl)pyrrolidine-2-carboxylic acid hydrochloride (R-6).

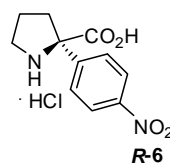

Product **5a** (234 mg, 0.8 mmol) was dissolved in CHCl₃ (6 mL); TFA (1.82 g, 16 mmol) was added, and this solution was stirred at reflux for 2 h. After evaporation under vacuum (RV), the crude was diluted with 10% HCl_{aq} (20 mL) and extracted with Et₂O (2×20 mL). The aqueous layer was evaporated (RV) and the product **R-7** (165 mg, 76%) was isolated as yellow solid, mp 160 °C (dec.), $[\alpha]_{\text{D}}^{20} = -49.5$ (*c* 1, MeOH), -11.1 (*c* 0.8 HCl 0.1%). ¹H NMR (200 MHz, D₂O+DCl) δ 7.82-7.75 (m, 2H), 7.24-7.20 (m, 2H), 3.21-2.96 (m, 2H), 2.59-2.48 (m, 1H), 2.21-2.04 (m, 1H), 1.78-1.54 (m, 2H), 2.17-2.04 (m, 1H). ¹³C NMR (75 MHz, D₂O+DCl) δ (2 conformational isomers) 174.3 and 174.3 (CO), 150.8, 143.5 and 143.4 (2 C_{Ar}), 130.4 and 130.3, 127.0 and 126.9 (4 C_{Ar}H), 77.3 and 77.2 (C), 48.1 and 48.0 (CH₂N), 35.8 and 35.7, 24.7 and 24.6 (CH₂). IR (nujol) 3212, 2256, 1636, 1349, 1114, 843, 761 cm⁻¹. Anal. Calcd. for C₁₁H₁₂N₂O₄: C, 55.93; H, 5.12; N, 11.86. Found: C, 55.89; H, 5.11; N, 11.88.

Synthesis of (R)-*t*-Butyl 1-[2-(4-bromophenyl)acetyl]-2-(4-nitrophenyl)pyrrolidine-2-carboxylate (8)

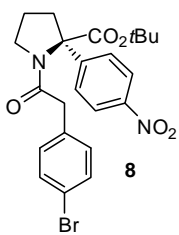

To a solution of compound **5a** (234 mg, 0.8 mmol) in pyridine (1.6 mL) was added 2-(4-bromophenyl)acetyl chloride (374 mg, 1.6 mmol). The resulting solution was stirred at 25 °C for 24 h, then the crude was diluted with dichloromethane (20 mL), washed with cold 3% HCl_{aq} (2×15 mL), and brine (20 mL), dried over MgSO₄ and filtered. After

evaporation of the solvent under vacuum (RV), the crude was purified by FCC [AcOEt/hexane (1:1)] to afford compound **8** (286 mg, 73%) as white solid, mp 84-85 °C (dec.), $[\alpha]_{D}^{20} = +96.4$ (*c* 1, CHCl₃). ¹H NMR (300 MHz, CDCl₃) δ 8.12-8.09 (m, 2H), 7.50-7.47 (m, 2H), 7.42-7.39 (m, 2H), 7.26-7.23 (m, 2H), 3.79-3.74 (m, 2H), 3.73 (s, 2H), 2.61-2.51 (m, 1H), 2.28-2.20 (m, 1H), 2.10-2.00 (m, 1H), 1.79-1.66 (m, 1H), 1.40 (s, 9H). ¹³C NMR (75 MHz, CDCl₃) δ 169.3, 168.8 (2 CO), 146.7, 146.5, 132.7, 121.0 (4 C_{Ar}), 131.7, 130.8, 128.2, 122.4 (8 C_{Ar}H), 82.3, 72.6 (2 C), 48.5 (CH₂N), 41.3, 41.1, 23.9 (3 CH₂), 27.6 (3 CH₃ *t*-Bu). Anal. Calcd. for C₂₃H₂₅BrN₂O₅: C, 56.45; H, 5.15; N, 5.72. Found: C, 56.51; H, 5.16; N, 5.69.

X-Ray Crystallographic Analysis for Compound **8**.

X-Ray data were collected on a diffractometer Bruker SMART-APEX with CCD area-detector, using graphite monochromated Mo-K α radiation ($\lambda=0.71073$ Å). Crystal data: C₂₃H₂₅BrN₂O₅, M = 489.36, orthorhombic, *P*2₁2₁2₁, room temperature, *a* = 8.682(5), *b* = 13.285(9), *c* = 20.868(10) Å, *V* = 2407(2) Å³, *Z* = 4, *D*_x = 1.350 Mg.m⁻³, μ = 1.742 mm⁻¹. The crystals were very poorly diffracting, and in spite of the quite large crystal dimensions (0.14x0.26x0.46 mm⁻¹) no reflection was found over $2\theta = 46$ °. Any attempt to collect data at lower temperature, to increase the quality and the number of data, failed because of a phase transition with twinning near room temperature, so that the final decision was to collect data at room temperature with a large redundancy and large time of exposure (60"/frame). 76023 measured reflections below $\theta = 23.00$ °, 3351 independent, *R*_{ave} = 0.0632, 2813 with *I*_o > 2 σ (*I*_o). Data collection, reduction and cell determination were carried on by SMART and SAINT;¹¹⁹ empirical absorption correction based on multi-scan was applied (*T*_{min}/*T*_{max}=0.7487). The structure was solved by SIR92,¹²⁰ and refined by

¹¹⁹ Bruker (1999). SMART and SAINT. Bruker AXS Inc., Madison, Wisconsin, USA.

¹²⁰ Altomare, A.; Cascarano, G.; Giacovazzo, G.; Guagliardi, A.; Burla, M. C.; Polidori, G.; Camalli, G. *J. Appl. Crystallogr.* **1994**, *27*, 435.

SHELX97;¹²¹ the 4-bromobenzyl and, partially, the proline ring were disordered and split for the refinement in two models with population factors 0.683/0.317; the nitro and *tert*-butyl groups present very large ADPs but we did not split these groups, avoiding a large decreasing of the ratio data/parameters, already quite low; split models were refined imposing soft restraints on their geometry and on ADPs. Non-H atom were anisotropic, H atoms were fixed in calculated positions; 353 parameters refined, 308 restraints, $R_1 = 0.0546$ for $I_o > 2\sigma(I_o)$ and 0.1189 for all data. The crystal structures have been deposited at the Cambridge Crystallographic Data Centre and allocated the deposition number CCDC 765702.

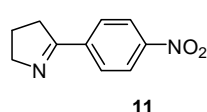

5-(4-Nitrophenyl)-3,4-dihydro-2H-pyrrole (11)

(4-Nitrophenylsulfonamido)-*L*-proline methyl ester **10**, 314 mg; **11** (105 mg, 55%, 16 h). FCC: AcOEt/hexane (1:4); yellow solid, mp 85-86

°C (dec.), ¹H NMR (300 MHz, CDCl₃) δ 8.28-8.23 (m, 2H), 8.02-7.97 (m, 2H), 4.16-4.10 (m, 2H), 3.01-2.94 (m, 2H), 2.15-2.05 (m, 2H). ¹³C NMR (75 MHz, CDCl₃) δ 171.7 (C=N), 148.9, 140.2 (2 C_{Ar}), 128.5, 123.7 (4 C_{Ar}H), 62.0, 35.1, 22.7 (3 CH₂). IR (nujol) 1617, 1595, 1513, 1334, 856, 726 cm⁻¹; MS (ESI) Calcd for C₁₀H₁₀N₂O₂ [M+H]⁺ 191.1 (100%), 192.1 (11.0%), found 191.2 (100%), 192.2 (11%). Anal. Calcd. for C₁₀H₁₀N₂O₂: C, 63.15; H, 5.30; N, 14.73. Found: C, 63.12; H, 5.35; N, 14.70.

¹²¹ Sheldrick, G. M. "SHELX97. Program for the Refinement of Crystal Structures", 1997, University of Göttingen, Germany.

Synthesis of 2-(4-nitrophenylsulphonamido)carboxylic esters 15, 20, 21.

To a suspension of the α -amino ester hydrochloride (10 mmol) in dry dichloromethane (40 mL), DIPEA (21 mmol) was added dropwise (10 min) at 25 °C. The reaction mixture was stirred for further 10 min, then cooled to 0 °C, and the sulphonyl chloride (10 mmol) was added dropwise (10 min). The resulting solution was stirred until completion (TLC control), then was diluted with dichloromethane (20 mL), washed with saturated NH₄Cl solution (2×15 mL), saturated NaHCO₃ solution (2×15 mL) and brine (20 mL), dried over MgSO₄, and filtered. After evaporation of the solvent under vacuum (RV), the crude was purified by FCC to afford sulphonamides 1. Starting material, product, yield, chromatographic eluant, physical and analytical data are as follows.

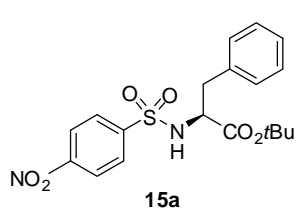

(S)-tert-Butyl 2-(4-nitrophenylsulphonamido)-3-phenylpropanoate (15a)

L-Phenylalanine *tert*-butyl ester hydrochloride, 2.58 g; sulphonamide **15a** (4.02 g, 99%, 2 h); FCC - AcOEt/hexane (1:6); white solid, mp 79-81°C, $[\alpha]_{\text{D}}^{20} = +5.74$ (c 1, CHCl₃). ¹H NMR (300 MHz, CDCl₃) δ 8.21 (d, 2H, *J* = 8.7), 7.87 (d, 2H, *J* = 8.7), 7.22-7.20 (m, 3H), 7.11-7.08 (m, 2H), 5.35 (d, 1H, *J* = 9.4), 4.16-4.09 (m, 1H), 3.09-2.92 (m, 2H), 1.28 (s, 9H). ¹³C NMR (75 MHz, CDCl₃) δ 169.7 (CO), 149.9 (C_{Ar}NO₂), 145.7 (C_{Ar}SO₂), 135.1 (C_{Ar}CH₂), 129.5, 128.5, 128.3, 127.3, 124.1 (9 CH_{Ar}), 83.3 (C_{tBu}), 57.4 (CHN), 39.4 (CH₂Ph), 27.7 (3 CH_{3-tBu}). IR (nujol) 3297, 1754, 1549, 1365, 1342, 1302, 1261, 1172, 1154, 1089, 1066, 949, 856, 835, 746 cm⁻¹. Anal. Calcd. for C₁₉H₂₂N₂O₆S: C, 56.15; H, 5.46; N, 6.89. Found: C, 56.18; H, 5.49; N, 6.85.

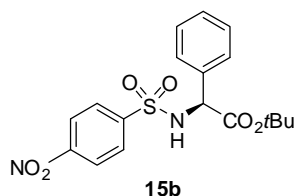

(S)-tert-Butyl 2-(4-nitrophenylsulphonamido)-2-phenylacetate (15b).

L-Phenylglycine *tert*-butyl ester hydrochloride, 2.44 g; sulphonamide **15b** (3.68 g, 94%, 2 h); FCC - AcOEt/hexane (1:8); white solid, mp 131-132°C, $[\alpha]_{\text{D}}^{20} = -68.3$ (c 1, CHCl₃). ¹H NMR (300 MHz, CDCl₃) δ 8.14 (d, 2H, *J* = 8.7), 7.79 (d, 2H, *J* = 8.7), 7.25-7.14 (m, 5H), 5.91 (d, 1H, *J* = 7.3), 5.03 (d, 1H, *J* = 7.3), 1.28 (s, 9H). ¹³C NMR (75 MHz, CDCl₃) δ 168.7 (CO), 149.8 (C_{Ar}NO₂), 146.3 (C_{Ar}SO₂), 135.2 (C_{Ar}CH), 128.7, 128.6, 128.3, 127.1, 123.8 (9 CH_{Ar}), 83.7 (C_{tBu}), 60.0 (CHN), 27.6 (3

CH_{3-*t*Bu}). IR (nujol) 3276, 1719, 1529, 1354, 1308, 1263, 1172, 1151, 1089, 1066, 931, 856, 835, 742 cm⁻¹. Anal. Calcd. for C₁₈H₂₀N₂O₆S: C, 55.09; H, 5.17; N, 7.14. Found: C, 55.03; H, 5.14; N, 7.10.

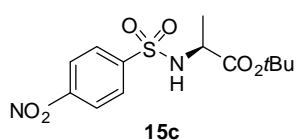

(S)-tert-Butyl 2-(4-nitrophenylsulphonamido)propanoate (15c).

L-Alanine *tert*-butyl ester hydrochloride, 1.81 g; sulphonamide **15c** (3.26 g, 99%, 2 h); FCC - AcOEt/hexane (1:8); white solid, mp 75-76°C, [α]_D²⁰ = +26.8 (*c* 1, CHCl₃). ¹H NMR (300 MHz, CDCl₃) δ 8.33 (d, 2H, *J* = 8.7), 8.03 (d, 2H, *J* = 8.7), 5.37 (d, 1H, *J* = 8.6), 3.98-3.89 (m, 1H), 1.38 (d, 3H, *J* = 7.1), 1.30 (s, 9H). ¹³C NMR (75 MHz, CDCl₃) δ 171.3 (CO), 150.5 (C_{Ar}NO₂), 146.6 (C_{Ar}SO₂), 128.9, 124.7 (4 CH_{Ar}), 83.4 (C_{tBu}), 52.6 (CHN), 28.1 (3 CH_{3-*t*Bu}), 20.3 (CH₃CH). IR (nujol) 3264, 1722, 1523, 1350, 1309, 1226, 1180, 1160, 1130, 1089, 859, 739 cm⁻¹. Anal. Calcd. for C₁₃H₁₈N₂O₆S: C, 47.23; H, 5.49; N, 8.48. Found: C, 47.26; H, 5.49; N, 8.52.

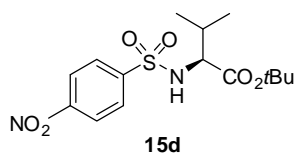

(S)-tert-Butyl

3-methyl-2-(4-

nitrophenylsulphonamido)butanoate (15d).

L-Valine *tert*-butyl ester hydrochloride, 2.10 g; sulphonamide **15d** (3.44 g, 96%, 2 h); FCC - AcOEt/hexane (1:8); white solid, mp 94-95°C, [α]_D²⁰ = +54.1 (*c* 1, CHCl₃). ¹H NMR (300 MHz, CDCl₃) δ 8.30 (d, 2H, *J* = 9.0), 8.03 (d, 2H, *J* = 9.0), 5.38 (d, 1H, *J* = 9.9), 3.68 (dd, 1H, *J* = 9.9, 4.4), 2.13-2.02 (m, 1H), 1.22 (s, 9H), 0.98 (d, 3H, *J* = 6.8), 0.83 (d, 3H, *J* = 6.8). ¹³C NMR (75 MHz, CDCl₃) δ 169.9 (CO), 150.0 (C_{Ar}NO₂), 145.9 (C_{Ar}SO₂), 128.6, 124.1 (4 CH_{Ar}), 82.7 (C_{tBu}), 61.5 (CHN), 31.5 (CH_{iPr}), 27.6 (3 CH_{3-*t*Bu}), 18.9, 17.0 (2 CH_{3-*i*Pr}). IR (nujol) 3301, 1721, 1698, 1524, 1363, 1347, 1310, 1248, 1182, 1158, 1081, 913, 856, 790, 739, 684 cm⁻¹. Anal. Calcd. for C₁₅H₂₂N₂O₆S: C, 50.27; H, 6.19; N, 7.82. Found: C, 50.31; H, 6.23; N, 7.79.

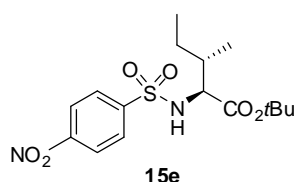

(2S,3S)-tert-Butyl

3-methyl-2-(4-

nitrophenylsulphonamido)pentanoate (15e).

L-Isoleucine *tert*-butyl ester hydrochloride, 2.24 g; sulphonamide **15e** (3.39 g, 91%, 2 h); FCC - AcOEt/hexane (1:9); white solid, mp 71-73°C, [α]_D²⁰ = +51.0 (*c* 1, CHCl₃). ¹H NMR (300 MHz, CDCl₃) δ 8.31 (d, 2H, *J* = 8.7), 8.02 (d, 2H, *J* = 8.7), 5.37 (d, 1H, *J* = 9.8), 3.73 (dd, 1H, *J* = 9.8, 4.9), 1.84-1.76 (m, 1H), 1.40-1.27 (m, 1H), 1.23 (s, 9H), 1.13-1.08 (m, 1H), 0.94 (d, 3H, *J* = 6.8), 0.88 (t, 3H, *J* = 7.4). ¹³C NMR (75 MHz, CDCl₃) δ 169.9 (CO), 150.1 (C_{Ar}NO₂), 145.9 (C_{Ar}SO₂), 128.6, 124.2 (4 CH_{Ar}), 82.9

(C_tBu), 60.9 (CHN), 38.6 (CH_sBu), 27.7 (3 CH_{3-t}Bu), 24.6 (CH₂CH₃), 15.5 (CH₃CH), 11.5 (CH₃CH₂). IR (nujol) 3285, 2970, 2935, 2878, 1729, 1607, 1531, 1457, 1350, 1309, 1253, 1164, 1138, 1092, 915, 855, 789, 736, 686 cm⁻¹. Anal. Calcd. for C₁₆H₂₄N₂O₆S: C, 51.60; H, 6.50; N, 7.52. Found: C, 51.64; H, 6.52; N, 7.49.

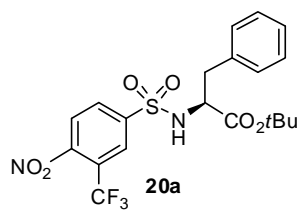

(S)-tert-butyl 2-(4-nitro-3-(trifluoromethyl)phenylsulfonamido)-3-phenylpropanoate (20a)

L-Phenylalanine *tert*-butyl ester hydrochloride, 2.58 g; sulphonamide **20a** (4.55 g, 96%, 2 h); FCC - AcOEt/hexane (1:4); white solid, °C, $[\alpha]_{\text{D}}^{20} = +5.74$ (*c* 1, CHCl₃). ¹H NMR (300 MHz, CDCl₃) δ 8.10 (d, 1H, *J* = 1.3), 7.95 (dd, 1H, *J* = 8.4, 1.3), 7.86 (d, 1H, *J* = 8.4), 7.17-7.05 (m, 5H), 5.96 (d, 1H, *J* = 9.6), 4.15-4.10 (m, 1H), 3.09 (dd, 1H, *J* = 13.9, 5.2), 5.77 (dd, 1H, *J* = 13.9, 8.3), 1.35 (s, 9H). ¹³C NMR (75 MHz, CDCl₃) δ 170.0 (CO), 144.5, 135.2, 135.1 (4 C_{Ar}), 131.8, 129.3, 128.5, 127.2, 126.7, 125.6 (8 CH_{Ar}), 83.4 (C_{tBu}), 57.9 (CHN), 39.0 (CH₂Ph), 27.6 (3 CH_{3-tBu}).. Anal. Calcd. for C₂₀H₂₁F₃N₂O₆S: C, 50.63; H, 4.46; N, 5.90. Found:.

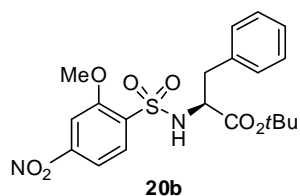

(S)-tert-butyl 2-(2-methoxy-4-nitrophenylsulfonamido)-3-phenylpropanoate (20b)

L-Phenylalanine *tert*-butyl ester hydrochloride, 2.58 g; sulphonamide **20b** (3.80 g, 87%, 2 h); FCC - AcOEt/hexane (1:4); white solid, mp 92.8-93.1 °C. ¹H NMR (300 MHz, CDCl₃) δ 7.99 (d, 1H, *J* = 8.5), 7.83 (dd, 1H, *J* = 8.5, 2.0), 7.74 (d, 1H, *J* = 2.0), 7.24-7.12 (m, 5H), 5.71 (d, 1H, *J* = 8.6), 4.15-4.10 (m, 1H), 3.99 (s, 3H), 3.05-3.02 (m, 2H), 1.17 (s, 9H). ¹³C NMR (75 MHz, CDCl₃) δ 169.7 (CO), 157.1, 151.5, 135.3, 133.5 (4 C_{Ar}), 130.5, 129.6, 128.4, 127.2, 115.1, 107.3 (8 CH_{Ar}), 82.8 (C_{tBu}), 57.5 (CH₃O), 57.0 (CHN), 39.7 (CH₂Ph), 27.9 (3 CH_{3-tBu}).. Anal. Calcd. for C₂₀H₂₄N₂O₇S: C, 55.03; H, 5.54; N, 6.42;. Found: C,

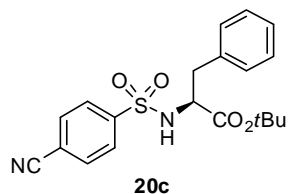

(S)-tert-butyl 2-(2-methoxy-4-nitrophenylsulfonamido)-3-phenylpropanoate (20c)

L-Phenylalanine *tert*-butyl ester hydrochloride, 2.58 g; sulphonamide **20c** (3.78 g, 98%, 2 h); FCC - AcOEt/hexane (1:4); white solid °C. ¹H NMR (300 MHz, CDCl₃) δ 7.80-7.77 (m, 2H), 7.65-7.62 (m, 2H), 7.23-7.07 (m, 5H), 5.78 (d, 1H, *J* = 9.4), 4.12-4.05 (m, 1H), 3.02 (dd, 1H, *J* = 13.9, 5.9), 2.92 (dd, 1H, *J* = 13.9, 7.3), 1.24 (s, 9H). ¹³C NMR (75 MHz, CDCl₃) δ 169.9 (CO), 144.4, 135.3, 117.3, 116.1 (5 C_{Ar}), 135.4, 132.7, 129.5, 128.5, 127.7, 127.2 (9 CH_{Ar}), 83.0 (C_{tBu}), 57.6 (CH), 39.3 (CH₂Ph), 27.7 (3 CH_{3-tBu}). Anal. Calcd. for C₂₀H₂₂N₂O₄S: C, 62.16; H, 5.74; N, 7.25. Found:

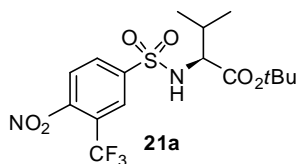

(S)-tert-butyl 3-methyl-2-(4-nitro-3-(trifluoromethyl)phenylsulfonamido)butanoate (21a).

L-Valine *tert*-butyl ester hydrochloride, 2.10 g; sulphonamide **21a** (3.88 g, 91%, 2 h); FCC - AcOEt/hexane (1:4); white solid, $[\alpha]_D^{20} = +54.1$ (*c* 1, CHCl₃). ¹H NMR (300 MHz, CDCl₃) δ 8.27 (d, 1H, *J* = 1.2), 8.21 (dd, 1H, *J* = 8.5, 1.2), 7.946 (d, 1H, *J* = 8.4), 5.54 (d, 1H, *J* = 10.0), 3.70 (dd, 1H, *J* = 10.0, 4.4), 2.16-2.02 (m, 1H), 1.25 (s, 9H), 0.98 (d, 3H, *J* = 6.8), 0.83 (d, 3H, *J* = 6.8). ¹³C NMR (75 MHz, CDCl₃) δ 169.9 (CO), 150.0, 144.4, 123.0, 119.3 (4 C_{Ar}), 132.3, 127.2, 125.7(3 CH_{Ar}), 83.2. (C_{tBu}), 61.6 (CHN), 31.5 (CH_{iPr}), 27.6 (3 CH_{3-tBu}), 19.1, 16.8 (2 CH_{3-iPr}). Anal. Calcd. for C₁₆H₂₁F₃N₂O₆S: C, 45.07; H, 4.96; N, 6.57. Found

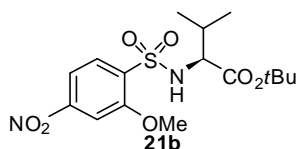

(S)-tert-butyl 2-(2-methoxy-4-nitrophenylsulfonamido)-3-methylbutanoate (21b).

L-Valine *tert*-butyl ester hydrochloride, 2.10 g; sulphonamide **21b** (3.42 g, 88%, 2 h); FCC - AcOEt/hexane (1:4); white solid. ¹H NMR (300 MHz, CDCl₃) δ 8.00 (d, 1H, *J* = 8.5), 7.83 (dd, 1H, *J* = 8.5, 2.0), 7.79 (d, 1H, *J* = 2.0), 5.70 (d, 1H, *J* = 9.4), 4.09 (s, 3H), 3.63 (dd, 1H, *J* = 9.4, 4.6), 2.02-1.96 (m, 1H), 1.16 (s, 9H), 0.97 (d, 3H, *J* = 6.8), 0.85 (d, 3H, *J* = 6.8). ¹³C NMR (75 MHz, CDCl₃) δ 170.1 (CO), 157.3, 151.5, 133.3 (3 C_{Ar}), 130.7, 114.9, 107.2 (3 CH_{Ar}), 83.2. (C_{tBu}), 61.7 (OCH₃), 57.2 (CHN), 31.8 (CH_{iPr}), 27.6 (3 CH_{3-tBu}), 18.9, 17.2 (2 CH_{3-iPr}). Anal. Calcd. for C₁₆H₂₄N₂O₇S: C, 49.47; H, 6.23; N, 7. Found

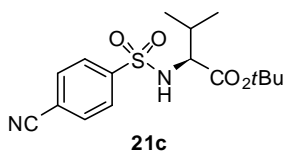

(S)-tert-butyl 2-(4-cyanophenylsulfonamido)-3-methylbutanoate (21c).

L-Valine *tert*-butyl ester hydrochloride, 2.10 g; sulphonamide **21b** (3.25 g, 96%, 2 h); FCC - AcOEt/hexane (1:4); white solid. ¹H NMR (300 MHz, CDCl₃) δ 7.97-7.94 (m, 2H), 7.77-7.74 (m, 2H), 5.50 (d, 1H, *J* = 9.9), 3.64 (dd, 1H, *J* = 9.9, 4.5), 2.10-1.99 (m, 1H), 1.22 (s, 9H), 0.95 (d, 3H, *J* = 6.8), 0.82 (d, 3H, *J* = 6.8). ¹³C NMR (75 MHz, CDCl₃) δ 169.9 (CO), 144.3, 117.1, 116.2 (3 C_{Ar}), 132.6, 127.9, 107.2 (4 CH_{Ar}), 82.6. (C_{tBu}), 61.4 (CHN), 31.4 (CH_{iPr}), 27.6 (3 CH_{3-tBu}), 18.9, 16.9 (2 CH_{3-iPr}). Anal. Calcd. for C₁₆H₂₂N₂O₄S: C, 56.78; H, 6.55; N, 8.28. Found.

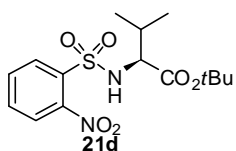

(S)-tert-butyl 3-methyl-2-(2-nitrophenylsulfonamido)butanoate (21d).

L-Valine *tert*-butyl ester hydrochloride, 2.10 g; sulphonamide **21d** (3.26 g, 91%, 2 h); FCC - AcOEt/hexane (1:4); white solid. ^1H NMR (300 MHz, CDCl_3) δ 8.05-8.02 (m, 1H), 7.89-7.6 (m, 1H), 7.71-7.68 (m, 2H), 6.02 (d, 1H, $J = 9.8$), 3.85 (dd, 1H, $J = 9.8, 5.0$), 2.16-2.07 (m, 1H), 1.17 (s, 9H), 0.99 (d, 3H, $J = 6.8$), 0.90 (d, 3H, $J = 6.8$). ^{13}C NMR (75 MHz, CDCl_3) δ 169.5 (CO), 147.7, 134.2 (2 C_{Ar}), 133.5, 132.8, 130.3, 125.4 (4 CH_{Ar}), 82.3. (C_{tBu}), 61.5 (CHN), 31.6 (CH_{iPr}), 27.8 (3 $\text{CH}_{3\text{-tBu}}$), 18.9, 17.2 (2 $\text{CH}_{3\text{-iPr}}$). Anal. Calcd. for $\text{C}_{15}\text{H}_{22}\text{N}_2\text{O}_6\text{S}$: C, 50.27; H, 6.19; N, 7.82. Found

'One-pot' alkylation/rearrangement of 4-nitrophenylsulphonamido esters 16a-h, 18b-e, 19c-e, 22a-d, 23a-d: General Procedure

In a flame-dried round bottomed flask, 60% sodium hydride (120 mg, 3 mmol) was rinsed with anhydrous *n*-pentane, under nitrogen. After cooling at 0 °C, a solution of sulphonamido ester (1 mmol) in anhydrous DMA (3 mL) was added dropwise. The reaction mixture was stirred until hydrogen evolution ended (ca. 30 min), then a solution of the alkylating agent RX (3 mmol) in anhydrous DMA (1 mL) was added by syringe. The resulting solution was stirred at 0 °C until completion (TLC analysis), then it was quenched with saturated NH₄Cl solution (1 mL). After dilution with AcOEt (20 mL) and water (20 mL), the organic phase was separated, dried on MgSO₄, evaporated under reduced pressure (RV), and the crude was purified by FCC on silica gel.

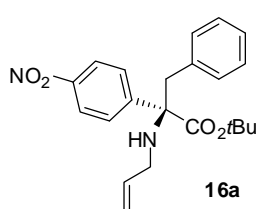

(R)-tert-Butyl 2-(allylamino)-2-(4-nitrophenyl)-3-phenylpropanoate

(16a). Sulphonamide **15a**, 406 mg; allyl bromide, 363 mg; **16a** (333 mg, 87%, 5 h); FCC - AcOEt/hexane (1:15); yellow oil, $[\alpha]_{\text{D}}^{20} = +13.5$

(*c* 0.3, CHCl₃), *ee* 62% [CHIRALPAK AD, hexane/*i*PrOH (95:5), flow rate 1 mL/min, P 18 bar, *t*₁ 5.08, *t*₂ 6.19]. ¹H NMR (300 MHz, CDCl₃) δ 8.14 (d, 2H, *J* = 8.7), 7.56 (d, 2H, *J* = 8.7), 7.21-7.18 (m, 3H), 6.97-6.93 (m, 2H), 6.03-5.92 (m, 1H), 5.30 (dd, 1H, *J* = 16.9, 1.2), 5.17 (d, 1H, *J* = 10.3), 3.38 (s, 2H), 3.28 (dd, 1H, *J* = 13.7, 5.4), 3.16 (dd, 1H, *J* = 13.7, 5.7), 1.97 (br, 1H), 1.48 (s, 9H). ¹³C NMR (75 MHz, CDCl₃) δ 172.1 (CO), 148.8 (C_{Ar}), 147.0 (C_{Ar}NO₂), 136.1 (CH_{AlI}), 135.5 (C_{Ar}), 130.5, 128.0, 127.9, 126.7, 122.9 (9 CH_{Ar}), 115.9 (CH_{2-All}), 82.4 (C_{tBu}), 69.7 (C_α), 46.2 (CH_{2N}), 42.6 (CH_{2Ph}), 27.9 (3 CH_{3-tBu}). IR (neat) 3348, 3084, 3065, 3031, 1725, 1496, 1249, 842, 749 cm⁻¹. Anal. Calcd. for C₂₂H₂₆N₂O₄: C, 69.09, H, 6.85; N, 7.32. Found: C, 69.07, H, 6.83; N, 7.30.

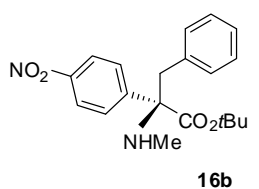

(R)-tert-Butyl 2-(methylamino)-2-(4-nitrophenyl)-3-

phenylpropanoate (16b). Sulphonamide **15a**, 406 mg; methyl iodide, 426 mg; **16b** (342 mg, 96%, 7 h); FCC - AcOEt/hexane (1:6); yellow oil,

$[\alpha]_{\text{D}}^{20} = +21.4$ (*c* 1.5, CHCl₃), *ee* 80% [CHIRALPAK AD, hexane/*i*PrOH (8:2), flow rate 0.7 mL/min, P 15 bar, *t*₁ 7.89, *t*₂ 10.18]. ¹H NMR (300 MHz, CDCl₃) δ 8.15 (d, 2H, *J* = 9.0), 7.54 (d, 2H, *J* = 9.0), 7.21-7.19 (m, 3H), 6.97-6.94 (m, 2H), 3.42 (d, 1H, *J* = 13.8), 3.25 (d, 1H, *J* = 13.8), 2.43 (s, 3H), 2.20 (br, 1H), 1.48 (s, 9H). ¹³C NMR (75 MHz, CDCl₃) δ 172.1 (CO), 148.7 (C_{Ar}), 147.0 (C_{Ar}NO₂), 135.5 (C_{Ar}), 130.4, 128.0, 127.8, 126.7,

122.9 (9 CH_{Ar}), 82.4 (C_{tBu}), 70.3 (C_α), 41.3 (CH₂Ph), 30.1 (CH₃N), 27.9 (3 CH_{3-tBu}). IR (neat) 3354, 2803, 1943, 1726, 1603, 1520, 1347, 1031, 800 cm⁻¹. Anal. Calcd. for C₂₀H₂₄N₂O₄: C, 67.40; H, 6.79; N, 7.86. Found: C, 67.37; H, 6.77; N, 7.82.

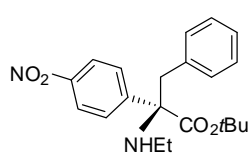

(*R*)-*tert*-Butyl

2-(ethylamino)-2-(4-nitrophenyl)-3-

phenylpropanoate (**16c**). Sulphonamide **15a**, 406 mg; ethyl iodide,

468 mg; **16c** (367 mg, 99%, 5 h); FCC - AcOEt/hexane (1:6); yellow

16c oil, $[\alpha]_{\text{D}}^{20} = +12.1$ (c 0.87, CHCl₃), *ee* 56% [CHIRALPAK AD,

hexane/*i*PrOH (95:5), flow rate 0.7 mL/min, P 12 bar, *t*₁ 7.16, *t*₂ 8.45]. ¹H NMR (300 MHz, CDCl₃) δ 8.08 (d, 2H, *J* = 9.0 Hz), 7.49 (d, 2H, *J* = 9.0 Hz), 7.15-7.12 (m, 3H), 6.90-6.87 (m, 2H), 3.31 (s, 2H), 2.65-2.50 (m, 2H), 1.77 (br, 1H), 1.42 (s, 9H), 1.15 (t, 3H, *J* = 7.0 Hz). ¹³C NMR (75 MHz, CDCl₃) δ 172.3 (CO), 149.1 (C_{Ar}), 147.0 (C_{Ar}NO₂), 135.7 (C_{Ar}), 130.4, 128.0, 127.8, 126.7, 122.9 (9 CH_{Ar}), 82.3 (C_{tBu}), 70.0 (C_α), 42.0 (CH₂Ph), 37.9 (CH₂N), 27.9 (3 CH_{3-tBu}), 15.5 (CH₃). IR (neat) 3348, 3076, 3029, 2927, 1730, 1597, 851 cm⁻¹. Anal. Calcd. for C₂₁H₂₆N₂O₄: C, 68.09; H, 7.07; N, 7.56. Found: C, 68.13; H, 7.10; N, 7.52.

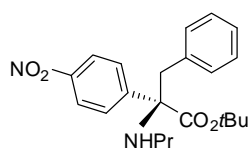

(*R*)-*tert*-Butyl

2-(4-nitrophenyl)-3-phenyl-2-

(propylamino)propanoate (**16d**).

Sulphonamide **15a**, 406 mg; propyl iodide, 510 mg; **16d** (308 mg,

16d 80%, 5 h); FCC - AcOEt/hexane (1:6); yellow oil, $[\alpha]_{\text{D}}^{20} = +13.3$ (c

0.91, CHCl₃), *ee* 56% [CHIRALPAK AD, hexane/*i*PrOH (95:5), flow rate 0.7 mL/min, P 12 bar, *t*₁ 7.20, *t*₂ 8.49]. ¹H NMR (300 MHz, CDCl₃) δ 8.08 (d, 2H, *J* = 9.0 Hz), 7.48 (d, 2H, *J* = 9.0 Hz), 7.15-7.13 (m, 3H), 6.90-6.88 (m, 2H), 3.31 (s, 2H), 2.60-2.41 (m, 2H), 1.80 (br, 1H), 1.63-1.52 (m, 2H), 1.42 (s, 9H), 0.96 (t, 3H, *J* = 7.4 Hz). ¹³C NMR (75 MHz, CDCl₃) δ 172.4 (CO), 149.2 (C_{Ar}), 146.9 (C_{Ar}NO₂), 135.7 (C_{Ar}), 130.5, 128.0, 127.8, 126.7, 122.9 (9 CH_{Ar}), 82.3 (C_{tBu}), 69.9 (C_α), 45.4 (CH₂Ph), 42.1 (CH₂N), 27.9 (3 CH_{3-tBu}), 23.6 (CH₂CH₃), 11.8 (CH₃CH₂). IR (neat) 3354, 3093, 3033, 2931, 1726, 1574, 843, 715 cm⁻¹. Anal. Calcd. for C₂₂H₂₈N₂O₄: C, 68.73; H, 7.34; N, 7.29. Found: C, 68.76; H, 7.36; N, 7.25.

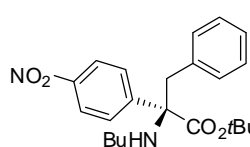

(*R*)-*tert*-Butyl

2-(butylamino)-2-(4-nitrophenyl)-3-

phenylpropanoate (**16e**).

Sulphonamide **15a**, 406 mg; butyl iodide, 552 mg; **16e** (343 mg,

16e 86%, 4 h); FCC - AcOEt/hexane (1:15); yellow oil, $[\alpha]_{\text{D}}^{20} = +12.7$ (c 1,

CHCl₃), *ee* 62% [CHIRALPAK AD, hexane/*i*PrOH (95:5), flow rate 0.6 mL/min, P 10 bar,

t_1 7.41, t_2 8.76]. $^1\text{H NMR}$ (300 MHz, CDCl_3) δ 8.13 (d, 2H, $J = 9.0$), 7.53 (d, 2H, $J = 9.0$), 7.19-7.17 (m, 3H), 6.94-6.93 (m, 2H), 3.35 (s, 2H), 2.66-2.51 (m, 2H), 1.87 (br, 1H), 1.60-1.30 (m, 4H), 1.47 (s, 9H), 0.97 (t, 3H $J = 7.2$). $^{13}\text{C NMR}$ (75 MHz, CDCl_3) δ 172.4 (CO), 149.1 (C_{Ar}), 146.8 ($\text{C}_{\text{Ar}}\text{NO}_2$), 135.8 (C_{Ar}), 130.4, 127.9, 127.7, 126.6, 122.7 (9 CH_{Ar}), 82.1 (C_{tBu}), 69.8 (C_{α}), 43.1 (CH_2Ph), 42.1, 32.6 (2 CH_2), 27.8 (3 $\text{CH}_3\text{-tBu}$), 20.4 (CH_2CH_3), 13.9 (CH_3CH_2). IR (neat) 3341, 3087, 3031, 2930, 1725, 1604, 843, 735 cm^{-1} . Anal. Calcd. for $\text{C}_{23}\text{H}_{30}\text{N}_2\text{O}_4$: C, 69.32; H, 7.59; N, 7.03. Found: C, 69.29; H, 7.57; N, 7.06.

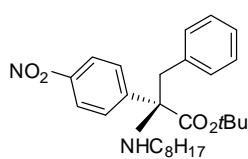

(R)-tert-Butyl 2-(octylamino)-2-(4-nitrophenyl)-3-phenylpropanoate (16f).

Sulphonamide **15a**, 406 mg; octyl iodide, 720 mg; **16f** (332 mg, 73%, 6 h); FCC - AcOEt/hexane (1:15); yellow oil, $[\alpha]_{\text{D}}^{20} = +9.7$ (c 0.3, CHCl_3), ee 61% [CHIRALPAK AD, hexane/ i PrOH (98:2), flow rate 0.7 mL/min, P 11 bar, t_1 6.44, t_2 8.15]. $^1\text{H NMR}$ (300 MHz, CDCl_3) δ 8.08 (d, 2H, $J = 8.8$ Hz), 7.47 (d, 2H, $J = 8.8$ Hz), 7.14-7.12 (m, 3H), 6.88-6.86 (m, 2H), 3.29 (s, 2H), 2.62-2.42 (m, 2H), 1.79 (br, 1H), 1.52-1.27 (m, 21H), 0.88 (t, 3H $J = 10.3$). $^{13}\text{C NMR}$ (75 MHz, CDCl_3) δ 173.1 (CO), 149.7 (C_{Ar}), 147.3 ($\text{C}_{\text{Ar}}\text{NO}_2$), 136.1 (C_{Ar}), 130.8, 128.3, 128.1, 127.0, 123.2 (9 CH_{Ar}), 82.3 (C_{tBu}), 68.1 (C_{α}), 43.3 (CH_2Ph), 41.8, 31.5, 30.2, 29.2, 28.9 (5 CH_2), 27.6 (3 $\text{CH}_3\text{-tBu}$), 27.0, 22.3 (2 CH_2), 13.7 (CH_3CH_2). IR (neat) 3368, 3063, 3031, 2928, 1726, 1521, 842, 737, 702 cm^{-1} . Anal. Calcd. for $\text{C}_{27}\text{H}_{38}\text{N}_2\text{O}_4$: C, 71.33; H, 8.43; N, 6.16. Found: C, 71.38; H, 8.45; N, 6.12

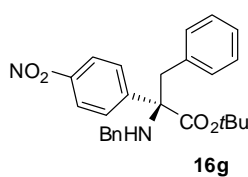

(R)-tert-Butyl 2-(benzylamino)-2-(4-nitrophenyl)-3-phenylpropanoate (16g).

Sulphonamide **15a**, 406 mg; benzyl bromide, 513 mg; **18g** (324 mg, 75%, 5 h); FCC - AcOEt/hexane (1:15); yellow oil, $[\alpha]_{\text{D}}^{20} = +6.7$ (c 1.2, CHCl_3), ee 51% [CHIRALPAK AD, hexane/ i PrOH (95:5), flow rate 0.7 mL/min, P 12 bar, t_1 9.26, t_2 10.24]. $^1\text{H NMR}$ (300 MHz, CDCl_3) δ 8.11 (d, 2H, $J = 8.9$ Hz), 7.56 (d, 2H, $J = 8.9$ Hz), 7.38-7.29 (m, 5H), 7.18-7.13 (m, 3H), 6.95-6.92 (m, 2H), 3.83 (d, 1H, $J = 12.3$ Hz), 3.66 (d, 1H, $J = 12.3$ Hz), 3.45 (d, 1H, $J = 13.8$), 3.37 (d, 1H, $J = 13.8$), 2.24 (br, 1H), 1.47 (s, 9H). $^{13}\text{C NMR}$ (75 MHz, CDCl_3) δ 172.7 (CO), 149.2 (C_{Ar}), 147.4 ($\text{C}_{\text{Ar}}\text{NO}_2$), 140.2 (C_{Ar}), 136.0 (C_{Ar}), 130.9, 129.0, 128.8, 128.4, 128.3, 127.7, 127.3, 123.4 (14 CH_{Ar}), 82.9 (C_{tBu}), 70.4 (C_{α}), 48.3 (NCH_2Ph), 42.9 (CH_2Ph), 28.5 (3 $\text{CH}_3\text{-tBu}$). IR (neat) 3343, 3030, 1725, 1604, 1369, 843, 734 cm^{-1} . Anal. Calcd. for $\text{C}_{26}\text{H}_{28}\text{N}_2\text{O}_4$: C, 72.20; H, 6.53; N, 6.48. Found: C, 72.23; H, 6.55; N, 6.45.

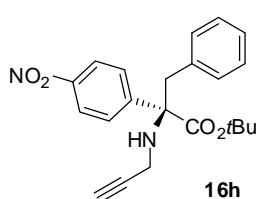

(R)-tert-Butyl

2-(4-nitrophenyl)-3-phenyl-2-(prop-2-

ynylamino)propanoate (16h).

Sulphonamide **15a**, 406 mg; propargyl bromide, 357 mg; **16h** (335 mg, 88%, 8 h); FCC - AcOEt/hexane (1:15); yellow oil, $[\alpha]_{\text{D}}^{20} = +3.7$ (*c* 0.2, CHCl₃), *ee* 80% [CHIRALPAK AD, hexane/*i*PrOH (95:5), flow rate 0.8 mL/min, P 14 bar, *t*₁ 10.48, *t*₂ 12.26]. ¹H NMR (300 MHz, CDCl₃) δ 8.17 (d, 2H, *J* = 9.0), 7.62 (d, 2H, *J* = 9.0), 7.24-7.22 (m, 3H), 7.05-7.01 (m, 2H), 3.50-3.29 (m, 4H), 2.28 (t, 1H, *J* = 2.7), 1.48 (s, 9H). ¹³C NMR (75 MHz, CDCl₃) δ 171.4 (CO), 147.7 (C_{Ar}NO₂), 147.0, 135.0 (2 C_{Ar}), 130.3, 127.9, 127.8, 126.8, 123.0 (9 CH_{Ar}), 82.8 (C_{propargyl}), 81.3 (C_{tBu}), 71.5 (CH_{propargyl}), 69.6 (C_α), 42.8 (CH₂Ph), 33.2 (CH₂N), 27.8 (3 CH_{3-tBu}). IR (neat) 3342, 3296, 2130, 1723, 1604, 1523, 856, 735 cm⁻¹. Anal. Calcd. for C₂₂H₂₄N₂O₄: C, 69.46; H, 6.36; N, 7.36. Found: C, 69.44; H, 6.32; N, 7.40.

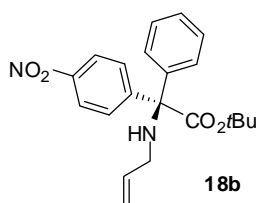

(R)-tert-Butyl

2-(allylamino)-2-(4-nitrophenyl)-2-phenylacetate

(18b).

Sulphonamide **15b**, 392 mg; allyl bromide, 363 mg; **18b** (339 mg, 92%, 26 h); FCC - AcOEt/hexane (1:12); yellow oil, $[\alpha]_{\text{D}}^{20} = +12.5$ (*c* 1, CHCl₃), *ee* 50% [CHIRALCEL OD, hexane/*i*PrOH (99:1), flow rate 0.7 mL/min, P 11 bar, *t*₁ 11.96, *t*₂ 12.88]. ¹H NMR (300 MHz, CDCl₃) δ 8.15 (d, 2H, *J* = 9.0), 7.75 (d, 2H, *J* = 9.0), 7.37-7.25 (m, 5H), 5.99-5.86 (m, 1H), 5.23 (dd, 1H, *J* = 17.1, 1.5), 5.09 (dd, 1H, *J* = 10.2, 1.5), 2.90-2.87 (m, 2H), 2.43 (br, 1H), 1.40 (s, 9H). ¹³C NMR (75 MHz, CDCl₃) δ 171.8 (CO), 149.5 (C_{Ar}NO₂), 147.3, 141.4 (2 C_{Ar}), 136.6 (CH_{All}), 130.0, 128.7, 128.2, 128.1, 123.3 (9 CH_{Ar}), 116.2 (CH_{2-All}), 83.3 (C_{tBu}), 73.1 (C_α), 47.1 (CH₂N), 28.2 (3 CH_{3-tBu}). IR (neat) 3331, 2979, 2932, 1726, 1644, 1604, 1520, 1368, 1348, 1246, 1153, 991, 918, 852, 733, 703 cm⁻¹. Anal. Calcd. for C₂₁H₂₄N₂O₄: C, 68.46; H, 6.57; N, 7.60. Found: C, 68.41; H, 6.55; N, 7.63.

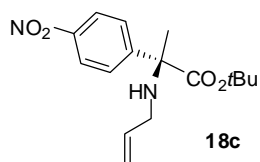

(R)-tert-Butyl 2-(allylamino)-2-(4-nitrophenyl)propanoate (18c).

Sulphonamide **15c**, 330 mg; allyl bromide, 363 mg; **18c** (273 mg, 89%, 6 h); FCC - AcOEt/hexane (1:7); yellow oil, $[\alpha]_{\text{D}}^{20} = -2.0$ (*c* 1, CHCl₃), *ee* 59% [CHIRALPAK AD, hexane/*i*PrOH (95:5), flow rate 1 mL/min, P 17 bar, *t*₁ 5.49, *t*₂ 6.18]. ¹H NMR (300 MHz, CDCl₃) δ 8.23 (d, 2H, *J* = 8.7), 7.73 (d, 2H, *J* = 8.7), 6.04-5.93 (m, 1H), 5.28 (dd, 1H, *J* = 17.1, 1.5), 5.16 (dd, 1H, *J* = 10.2, 1.2), 3.23-3.11 (m, 2H), 2.05 (br, 1H), 1.70 (s, 3H), 1.48 (s, 9H). ¹³C NMR (75 MHz, CDCl₃) δ 173.0 (CO), 151.1 (C_{Ar}), 147.0 (C_{Ar}NO₂), 136.4 (CH_{All}), 126.9, 123.3 (4 CH_{Ar}), 115.8 (CH_{2-All}),

82.0 (C_{tBu}), 65.6 (C_{α}), 46.5 (CH_2N), 27.7 (3 CH_{3-tBu}), 24.3 (CH_3). IR (neat) 3346, 2979, 2928, 1727, 1604, 1522, 1456, 1369, 1349, 1253, 1145, 1111, 855 cm^{-1} . Anal. Calcd. for $C_{16}H_{22}N_2O_4$: C, 62.73; H, 7.24; N, 9.14. Found: C, 62.76; H, 7.26; N, 9.11.

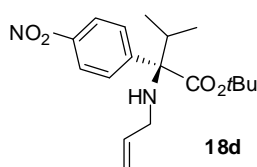

(R)-tert-Butyl

2-(allylamino)-3-methyl-2-(4-

nitrophenyl)butanoate (18d).

Sulphonamide **15d**, 358 mg; allyl bromide, 363 mg **18d** (331 mg, 99%, 24 h); FCC - AcOEt/hexane (1:12); yellow oil, $[\alpha]_D^{20} = -60.1$ (c 1.1, $CHCl_3$), *ee* 95% [CHIRALPAK AD, hexane/*i*PrOH (9:1), flow rate 0.8 mL/min, P 14 bar, t_1 5.04, t_2 6.61]. 1H NMR (300 MHz, $CDCl_3$) δ 8.21 (d, 2H, $J = 9.0$), 7.78 (d, 2H, $J = 9.0$), 6.03-5.91 (m, 1H), 5.29 (d, 1H, $J = 17.4$), 5.16 (dd, 1H, $J = 10.2, 1.5$), 3.12 (dd, 1H, $J = 13.5, 5.4$), 2.98 (dd, 1H, $J = 14.0, 4.2$), 2.43-2.40 (m, 1H), 1.70 (br, 1H), 1.56 (s, 9H), 0.90 (d, 3H, $J = 5.7$), 0.80 (d, 3H, $J = 6.9$). ^{13}C NMR (75 MHz, $CDCl_3$) δ 172.0 (CO), 146.8 (C_{Ar}), 145.1 ($C_{Ar}NO_2$), 136.4 (CH_{All}), 130.2, 121.9 (4 CH_{Ar}), 115.3 (CH_{2-All}), 81.8 (C_{tBu}), 72.6 (C_{α}), 46.5 (CH_2N), 35.6 (CH_{iPr}), 28.0 (3 CH_{3-tBu}), 18.4, 16.7 (2 CH_{3-iPr}). IR (neat) 3341, 2974, 2934, 1723, 1644, 1520, 1349, 1244, 1160, 885 cm^{-1} . Anal. Calcd. for $C_{18}H_{26}N_2O_4$: C, 64.65; H, 7.84; N, 8.38. Found: C, 64.69; H, 7.86; N, 8.35.

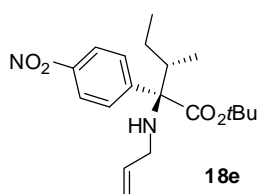

(2R,3S)-tert-Butyl

2-(allylamino)-3-methyl-2-(4-

nitrophenyl)pentanoate (18e).

Sulphonamide **15e**, 372 mg; allyl bromide, 363 mg; **18e** (345 mg, 99%, 26h); FCC - AcOEt/hexane (1:8); yellow oil, $[\alpha]_D^{20} = -53.2$ (c 1.2, $CHCl_3$), *de* 96% [CHIRALCEL OD, hexane/*i*PrOH (98:2), flow rate 0.8 mL/min, P 13 bar, t_1 5.04, t_2 5.63]. 1H NMR (300 MHz, $CDCl_3$) δ 8.14 (d, 2H, $J = 8.7$), 7.74 (d, 2H, $J = 9.0$), 5.97-5.86 (m, 1H), 5.25 (d, 1H, $J = 17.1$), 5.09 (d, 1H, $J = 10.2$), 3.05 (dd, 1H, $J = 13.8, 5.7$), 2.94 (dd, 1H, $J = 13.8, 4.5$), 2.06-2.02 (m, 1H), 1.88-1.81 (m, 1H), 1.71 (br, 1H), 1.52 (s, 9H), 0.87-0.80 (m, 6H), 0.46-0.32 (m, 1H). ^{13}C NMR (75 MHz, $CDCl_3$) δ 172.1 (CO), 146.8 (C_{Ar}), 145.5 ($C_{Ar}NO_2$), 136.4 (CH_{All}), 130.0, 122.0 (4 CH_{Ar}), 115.4 (CH_{2-All}), 81.8 (C_{tBu}), 72.9 (C_{α}), 46.6 (CH_2N), 43.0 (CH_{sBu}), 28.0 (3 CH_{3-tBu}), 23.5 (CH_2CH_3), 14.8 (CH_3CH), 12.2 (CH_3CH_2). IR (neat) 3338, 1743, 1639, 1525, 1298, 1217, 1106, 988, 889 cm^{-1} . Anal. Calcd. for $C_{19}H_{28}N_2O_4$: C, 65.49; H, 8.10; N, 8.04. Found C, 65.53; H, 8.14; N, 8.00.

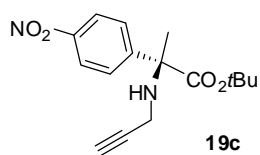

(R)-tert-Butyl 2-(4-nitrophenyl)-2-(prop-2-ynylamino)propanoate (19c).

Sulphonamide **15c**, 330 mg; propargyl bromide, 357 mg; **19c** (283 mg, 93%, 5h); FCC - AcOEt/hexane (1:7); yellow oil, $[\alpha]_{\text{D}}^{20} = -15.2$ (*c* 1, CHCl₃), *ee* 68% [CHIRALPAK AD, hexane/*i*PrOH (9:1), flow rate 0.8 mL/min, P 14 bar, *t*₁ 8.31, *t*₂ 13.53]. ¹H NMR (300 MHz, CDCl₃) δ 8.23 (d, 2H, *J* = 9.0), 7.73 (d, 2H, *J* = 9.0), 3.46 (dd, 1H, *J* = 16.5, 2.4), 3.35 (dd, 1H, *J* = 16.2, 2.4), 2.26 (t, 1H, *J* = 2.4), 1.72 (s, 3H), 1.48 (s, 9H); NH signal is not visible. ¹³C NMR (75 MHz, CDCl₃) δ 172.6 (CO), 150.4 (C_{Ar}NO₂), 147.1 (C_{Ar}), 126.9, 123.4 (4 CH_{Ar}), 82.4 (C_{propargyl}), 81.8 (C_{tBu}), 71.6 (CH_{propargyl}), 65.4 (C_α), 33.1 (CH_{2-propargyl}), 27.7 (3 CH_{3-tBu}), 23.8 (CH₃). IR (neat) 3299, 2980, 2935, 1724, 1605, 1520, 1477, 1457, 1369, 1348, 1253, 1164, 1128, 1087, 1014, 856, 845, 739, 700 cm⁻¹. Anal. Calcd. for C₁₆H₂₀N₂O₄: C, 63.14; H, 6.62; N, 9.20. Found: C, 63.18; H, 6.65; N, 9.17.

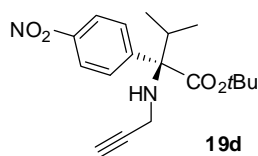

(R)-tert-Butyl 3-methyl-2-(4-nitrophenyl)-2-(prop-2-ynylamino)butanoate (19d).

Sulphonamide **15d**, 358 mg; propargyl bromide, 357 mg; **19d** (326 mg, 98%, 20 h); FCC -AcOEt/hexane (1:9); yellow oil, $[\alpha]_{\text{D}}^{20} = -77.0$ (*c* 1, CHCl₃), *ee* 96% [CHIRALPAK AD, hexane/*i*PrOH (9:1), flow rate 0.8 mL/min, P 14 bar, *t*₁ 5.649, *t*₂ 6.288]. ¹H NMR (300 MHz, CDCl₃) δ 8.23 (d, 2H, *J* = 9.0), 7.81 (d, 2H, *J* = 9.0), 3.32 (dd, 1H, *J* = 16.2, 2.4), 3.17 (dd, 1H, *J* = 16.2, 2.4), 2.49-2.40 (m, 1H), 2.28 (t, 1H, *J* = 2.4), 1.58 (s, 9H), 0.93 (d, 3H, *J* = 6.8), 0.82 (d, 3H, *J* = 6.9); NH signal is not visible. ¹³C NMR (75 MHz, CDCl₃) δ 171.5 (CO), 147.0 (C_{Ar}), 144.5 (C_{Ar}NO₂), 130.1, 122.3 (4 C_{Ar}), 82.4 (C_{propargyl}), 81.7 (C_{tBu}), 72.8 (CH_{propargyl}), 71.3 (C_α), 36.0 (CH_{tPr}), 33.8 (CH_{2-propargyl}), 28.0 (3 CH_{3-tBu}), 18.2, 16.9 (CH_{2-tPr}). IR (neat) 3303, 2974, 2934, 1720, 1604, 1522, 1459, 1369, 1350, 1249, 1160, 1136, 1108, 1015, 856, 822, 735 cm⁻¹. Anal. Calcd. for C₁₈H₂₄N₂O₄: C, 65.04; H, 7.28; N, 8.43. Found: C, 65.00; H, 7.26; N, 8.47.

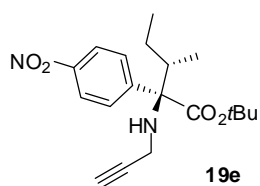

(2R,3S)-tert-butyl 3-methyl-2-(4-nitrophenyl)-2-(prop-2-ynylamino) pentanoate (19e).

Sulphonamide **15e**, 372 mg; propargyl bromide, 357 mg; **19e** (336 g, 97%, 26 h); FCC - AcOEt/hexane (1:10); yellow oil, $[\alpha]_{\text{D}}^{20} = -61.7$ (*c* 1, CHCl₃) *de* 98% [CHIRALCEL OD, hexane/*i*PrOH (98:2), flow rate 0.8 mL/min, P 13 bar, *t*₁ 7.156, *t*₂ 7.613]. ¹H NMR (300 MHz, CDCl₃) δ 8.12-8.09 (m, 2H), 7.71-7.68 (m, 2H),

3.19 (dd, 1H, $J = 16.1, 2.4$), 3.03 (dd, 1H, $J = 16.1, 2.5$), 2.19 (t, 1H, $J = 2.2$), 1.98 (br, 1H), 1.97-1.92 (m, 1H), 1.65-1.75 (m, 1H), 1.46 (s, 9H), 0.81-0.74 (m, 6H), 0.45-0.34 (m, 1H). ^{13}C NMR (75 MHz, CDCl_3) δ 172.0 (CO), 147.4 (C_{Ar}), 145.3 ($\text{C}_{\text{Ar}}\text{NO}_2$), 130.4, 122.7 (4 C_{Ar}), 82.8 ($\text{C}_{\text{propargyl}}$), 82.2 (C_{tBu}), 73.5 ($\text{CH}_{\text{propargyl}}$), 71.7 (C_{α}), 43.7 (CH_{sBu}), 34.2 ($\text{CH}_2\text{-propargyl}$), 28.4 (3 $\text{CH}_3\text{-tBu}$), 24.1 (CH_2CH_3), 15.0 (CH_3CH), 12.7 (CH_3CH_2). IR (neat) 3336, 2971, 2944, 1715, 1612, 1525, 1451, 1369, 1355, 1237, 1164, 1131, 1111, 1010, 851, 828, 731 cm^{-1} . Anal. Calcd. for $\text{C}_{19}\text{H}_{26}\text{N}_2\text{O}_4$: C, 65.87; H, 7.56; N, 8.09. Found: C, 65.90; H, 7.59; N, 8.05.

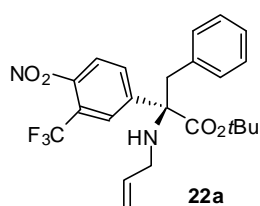

(R)-tert-butyl 2-(allylamino)-2-(4-nitro-3-(trifluoromethyl)phenyl)-3-phenylpropanoate (22a).

Sulphonamide **20a**, 426 mg; allyl bromide, 363 mg; **16a** (347 mg, 77%, 16 h); FCC - AcOEt/hexane (1:4); yellow oil, ee 61% [CHIRALPAK AD, hexane/ i PrOH (8:2), flow rate 1 mL/min, P 24 bar, t_1 4.11, t_2 4.62]. ^1H NMR (300 MHz, CDCl_3) δ 7.77-7.71 (m, 3H), 7.20-7.16 (m, 3H), 6.88-6.85 (m, 2H), 6.03-5.92 (m, 1H), 5.27 (dd, 1H, $J = 17.1$), 5.15 (d, 1H, $J = 10.3$), 3.36-3.19 (m, 3H), 3.28 (dd, 1H, $J = 13.7, 5.5$), 1.97 (br, 1H), 1.48 (s, 9H). ^{13}C NMR (75 MHz, CDCl_3) Anal. Calcd. for $\text{C}_{23}\text{H}_{25}\text{F}_3\text{N}_2\text{O}_4$: C, 61.33; H, 5.59; N, 6.22. Found:

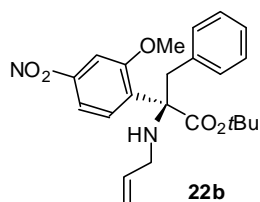

(R)-tert-butyl 2-(allylamino)-2-(2-methoxy-4-nitrophenyl)-3-phenylpropanoate (22b).

Sulphonamide **20b**, 437 mg; allyl bromide, 363 mg; **22b** (363 mg, 88%, 16 h); FCC - AcOEt/hexane (1:4); yellow oil, $[\alpha]_{\text{D}}^{20} = +49.2$ (c 1.1, CHCl_3), ee 40% [CHIRALPAK AD, hexane/ i PrOH (99:1), flow rate 1 mL/min, P 17 bar, t_1 12.13, t_2 13.49]. ^1H NMR (300 MHz, CDCl_3) δ 7.65 (d, 1H, $J = 2.1$), 7.61 (dd, 1H, $J = 8.5, 2.1$), 7.29 (d, 1H, $J = 8.5$), 7.05-7.02 (m, 3H), 6.76-6.73 (m, 2H), 6.03-5.92 (m, 1H), 5.29 (dd, 1H, $J = 17.2, 1.5$), 5.14 (d, 1H, $J = 11.5, 1.2$), 3.86 (s, 3H), 3.40-3.21 (m, 4H), 1.43 (s, 9H). Anal. Calcd. for $\text{C}_{23}\text{H}_{28}\text{N}_2\text{O}_5$: C, 66.97; H, 6.84; N, 6.79. Found:

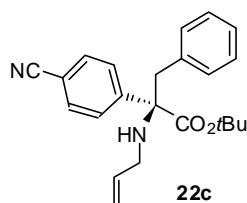

(R)-tert-butyl 2-(allylamino)-2-(4-cyanophenyl)-3-phenylpropanoate (22c).

Sulphonamide **20c**, 339 mg; allyl bromide, 363 mg; **22c** (221 mg, 61%, 16 h); FCC - AcOEt/hexane (1:4); yellow oil, $[\alpha]_{\text{D}}^{20} = +49.2$ (c 1.1, CHCl_3), ee 40% [CHIRALPAK AD, hexane/ i PrOH (99:1), flow rate 1 mL/min, P 17 bar, t_1 11.95, t_2 13.61]. ^1H NMR (300 MHz, CDCl_3) δ 7.55-7.53 (m, 2H), 7.52-7.43 (m, 2H),

7.16-7.12 (m, 3H), 6.91-6.88 (m, 2H), 6.03-5.92 (m, 1H), 5.25 (dd, 1H, $J = 17.2, 1.6$), 5.11 (dd, 1H, $J = 10.2, 1.6$), 3.33 (d, 2H, $J = 13.7$), 3.20 (dd, 1H, $J = 15.4, 5.6$), 3.11 (dd, 1H, $J = 15.4, 5.7$), 2.22 (br, 1H), 1.43 (s, 9H). ^{13}C NMR (75 MHz, CDCl_3) δ 171.9 (CO), 146.7, 118.8 (2C_{Ar}), 136.1 (CH_{All}), 131.6, 130.5, 128.5, 127.9, 126.7, 122.9 (9 CH_{Ar}), 115.8 ($\text{CH}_2\text{-All}$), 111.0 (CN), 82.3 (C_{tBu}), 69.7 (C_α), 46.2 (CH_2N), 42.5 (CH_2Ph), 27.9 (3 $\text{CH}_3\text{-tBu}$). Anal. Calcd. for $\text{C}_{23}\text{H}_{26}\text{N}_2\text{O}_2$: C, 76.21; H, 7.23; N, 7.73. Found:

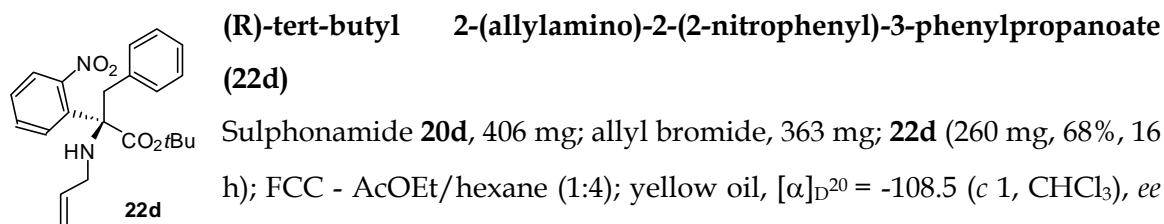

bar, t_1 5.73, t_2 6.85]. ^1H NMR (300 MHz, CDCl_3) δ 7.85-7.83 (m, 1H), 7.31-7.07 (m, 6H), 6.87-6.84 (m, 2H), 5.82-5.93 (m, 1H), 5.24 (dd, 1H, $J = 17.2, 1.6$), 5.08 (dd, 1H, $J = 10.3, 1.4$), 3.82 (d, 2H, $J = 13.9$), 3.43 (d, 1H, $J = 13.9$), 3.11 (dd, 1H, $J = 14.4, 5.7$), 2.91 (dd, 1H, $J = 14.4, 4.8$), 1.47 (s, 9H). ^{13}C NMR (75 MHz, CDCl_3) δ 169.8 (CO), 150.0, 136.3, 134.2 (3 C_{Ar}), 136.1 (CH_{All}), 131.4, 130.9, 130.7, 127.9, 127.3, 126.3, 124.6 (9 CH_{Ar}), 115.3 ($\text{CH}_2\text{-All}$), 82.9 (C_{tBu}), 68.3 (C_α), 45.7 (CH_2N), 43.3 (CH_2Ph), 27.9 (3 $\text{CH}_3\text{-tBu}$). IR (neat) 3348, 3084, 3065, 3031, 1725, 1496, 1249, 842, 749 cm^{-1} . Anal. Calcd. for $\text{C}_{22}\text{H}_{26}\text{N}_2\text{O}_4$: C, 69.09; H, 6.85; N, 7.32. Found:

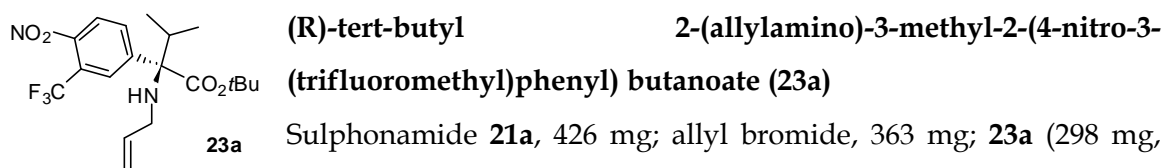

1.2, CHCl_3), ee 92% [CHIRALPAK AD, hexane/*i*PrOH (98:2), flow rate 0.5 mL/min, P 8 bar, t_1 8.724, t_2 9.219]. ^1H NMR (300 MHz, CDCl_3) δ 8.10 (d, 1H, $J = 1.2$), 7.91 (dd, 1H, $J = 8.6, 1.2$), 7.84 (d, 1H, $J = 8.6$), 5.95-5.87 (m, 1H), 5.27 (dd, 1H, $J = 17.2$), 5.13 (dd, 1H, $J = 10.3, 1.2$), 3.08 (dd, 1H, $J = 14.1, 5.9$), 2.86 (dd, 1H, $J = 14.1, 4.7$), 2.38-2.31 (m, 1H), 1.53 (s, 9H), 0.86 (d, 3H, $J = 6.3$), 0.73 (d, 3H, $J = 6.3$). ^{13}C NMR (75 MHz, CDCl_3) δ 171.8 (CO), 146.7, 143.2, 124.9, 119.5 (4 C_{Ar}), 136.0 (CH_{All}), 134.1, 129.1, 123.6 (3 CH_{Ar}), 115.7 ($\text{CH}_2\text{-All}$), 82.5 (C_{tBu}), 72.5 (C_α), 46.6 (CH_2N), 36.2 (CH), 28.1 (3 $\text{CH}_3\text{-tBu}$), 18.3, 16.5 (2 CH_3). Anal. Calcd. for $\text{C}_{19}\text{H}_{25}\text{F}_3\text{N}_2\text{O}_4$: C, 56.71; H, 6.26; N, 6.96. Found:

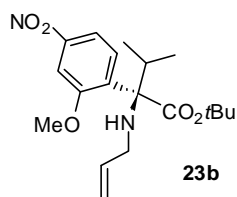

(R)-tert-butyl 2-(allylamino)-2-(2-methoxy-4-nitrophenyl)-3-methylbutanoate (23b)

Sulphonamide **21b**, 388 mg; allyl bromide, 363 mg; **23b** (306 mg, 84%, 16 h); FCC - AcOEt/hexane (1:4); yellow oil, $[\alpha]_{\text{D}}^{20} = -13.8$ (*c* 1, CHCl₃), *ee* 85% [CHIRALPAK AD, hexane/*i*PrOH (9:1), flow rate 1 mL/min, P 24 bar, *t*₁ 3.50, *t*₂ 4.02]. ¹H NMR (300 MHz, CDCl₃) δ 7.85-7.82 (m, 2H), 7.67 (d, 1H, *J* = 1.3), 5.99-5.92 (m, 1H), 5.19 (dd, 1H, *J* = 18.6, 1.5), 5.06 (dd, 1H, *J* = 10.1, 1.2), 3.83 (s, 3H), 3.10-2.98 (m, 2H), 2.62-2.48 (m, 1H), 1.42 (s, 9H), 0.86-0.83 (m, 6H). ¹³C NMR (75 MHz, CDCl₃) δ 171.1 (CO), 157.4, 147.9, 134.2 (3C_{Ar}), 136.6 (CH_{All}), 129.8, 115.0, 105.3 (3 CH_{Ar}), 115.4 (CH_{2-All}), 80.7 (C_{tBu}), 68.6 (C_α), 55.2 (CH_{3O}), 45.5 (CH_{2N}), 31.1 (CH), 28.0 (3 CH_{3-tBu}), 18.5, 17.0 (2 CH₃). Anal. Calcd. For C₁₉H₂₈N₂O₅: C, 62.62; H, 7.74; N, 7.69. Found

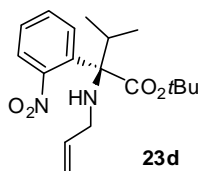

(R)-tert-butyl 2-(allylamino)-2-(4-cyanophenyl)-3-methylbutanoate (23c)

Sulphonamide **21c**, 358 mg; allyl bromide, 363 mg; **23b** (237 mg, 92%, 16 h); FCC - AcOEt/hexane (1:4); yellow oil, $[\alpha]_{\text{D}}^{20} = -132.0$ (*c* 1.1, CHCl₃), *ee* 85% [CHIRALPAK AD, hexane/*i*PrOH (99:1), flow rate 1 mL/min, P 17 bar, *t*₁ 5.78, *t*₂ 6.87]. ¹H NMR (300 MHz, CDCl₃) δ 7.84-7.81 (m, 1H), 7.74-7.71 (m, 1H), 7.41-7.50 (m, 1H), 7.41-7.36 (m, 1H), 5.87-5.80 (m, 1H), 5.16 (dd, 1H, *J* = 17.2, 1.5), 5.03 (dd, 1H, *J* = 10.2, 1.2), 2.92 (d, 2H, *J* = 5.3), 2.84-2.97 (m, 1H), 1.46 (s, 9H), 1.09 (d, 3H, *J* = 6.8), 0.95 (d, 3H, *J* = 6.8). ¹³C NMR (75 MHz, CDCl₃) δ 177.1 (CO), 141.7, 134.6 (2 C_{Ar}), 136.6 (CH_{All}), 131.1, 130.6, 127.9, 125.1 (4 CH_{Ar}), 115.3 (CH_{2-All}), 83.7 (C_{tBu}), 70.0 (C_α), 46.0 (CH_{2N}), 33.8 (CH), 28.0 (3 CH_{3-tBu}), 19.0, 18.8 (2 CH₃). Anal. Calcd. For C₁₈H₂₆N₂O₄: C, 64.65; H, 7.84; N, 8.38. Found

Synthesis of (*R*)-2-amino-2-(4-nitrophenyl)propanoic acid (**R-24**)

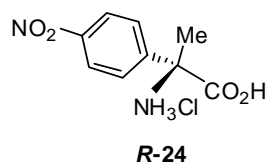

Tetrakis(triphenylphosphine)palladium(0) (81 mg, 0.07 mmol) was added to a solution of (*R*)-*tert*-butyl 2-(allylamino)-2-(4-nitrophenyl)propanoate (**18c**) (306 mg, 1 mmol) and dimedone (178 mg, 1.2 mmol) in THF (5 mL) previously purged with nitrogen through three freeze-pump-thaw cycles. The reaction mixture was stirred at 25 °C overnight; the crude, after solvent evaporation, was purified by FCC - AcOEt/hexane (1:4) on silica gel. The isolated product **6** (229 mg, 0.86 mmol, 86%) was dissolved in CHCl₃ (6 mL), TFA (1.96 g, 17.2 mmol) was added, and this solution was stirred at 62 °C for 2 h. After evaporation under reduced pressure (RV), the crude was diluted with 10% HCl_{aq} (20 mL) and extracted with Et₂O (2 X 20 mL). The aqueous layer was evaporated (RV) and the product **R-24** (187 mg, 88%) was isolated as a white solid, mp 148-149 °C (lit.^[122] 152-153 °C). [α]_D²⁰ = -38.0 (*c* 0.44, 1 N HCl) *ee* 53% [lit. ^[1] **S-7**: [α]_D²⁰ = +79.2 (*c* 0.6, 1 N HCl); ¹H NMR (300 MHz, D₂O) δ 8.37 (d, 2H, *J* = 8.7), 7.81 (d, 2H, *J* = 8.7), 2.07 (s, 3H). ¹³C NMR (75 MHz, CDCl₃) δ 175.3 (CO), 148.3 (C_{Ar}NO₂), 145.3 (C_{Ar}), 127.9, 124.8 (4 CH_{Ar}), 63.3 (C _{α}), 22.1 (CH₃).

[122] F. A. Davis, S. Lee, H. Zhang, D. L. Fanelli *J. Org. Chem.* 2000, 65, 8704

Alkylation of 4-nitrophenylsulfonamido esters 17a-e, 28a-m under SL-PTC conditions:

General Procedure

In a screw cap vial, a heterogeneous mixture of starting sulphonamido ester (1 mmol), TEBA (0.23 g, 1 mmol), and allyl bromide (3.63 g, 30 mmol) solution in anhydrous acetonitrile (30 mL) and anhydrous potassium carbonate (2.21 g, 16 mmol) was vigorously stirred at 25 °C until completion (TLC analysis). The crude was then diluted with AcOEt (30 mL) and filtered through a celite pad. After evaporation of the solvent under reduced pressure (RV), purification of the crude by FCC - AcOEt/hexane (1:10) - on silica gel gave the *N*-alkyl sulphonamido ester

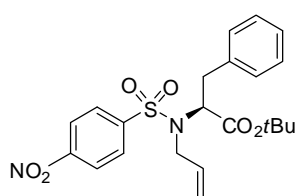

17a

(*S*)-*tert*-butyl 2-(*N*-allyl-4-nitrophenylsulphonamido)-3-phenyl propanoate (17a)

3a (4.11 mg, 92%); $[\alpha]_{\text{D}}^{20} = -11.3$ (*c* 0.4, CHCl₃). ¹H NMR (300 MHz, CDCl₃) δ 8.16 (d, 2H, *J* = 9.0), 7.74 (d, 2H, *J* = 8.7), 7.28-7.20 (m, 5H), 5.73-5.64 (m, 1H), 5.23 (dd, 1H, *J* = 17.1, 1.2), 5.11 (dd, 1H, *J* = 10.2, 1.2), 4.81 (dd, 1H, *J* = 8.7, 6.9), 4.02 (ddt, 1H, *J* = 16.5, 6.3, 1.5), 3.87 (ddt, 1H, *J* = 16.5, 6.9, 1.5), 3.32 (dd, 1H, *J* = 14.1, 6.6), 2.97 (dd, 1H, *J* = 14.4, 8.7), 1.33 (s, 9H). ¹³C NMR (75 MHz, CDCl₃) δ 168.9 (CO), 149.6 (C_{Ar}NO₂), 146.2 (C_{Ar}SO₂), 135.2 (C_{Ar}CH₂), 134.0 (CH_{All}), 129.1, 128.5, 128.4, 126.8, 123.7 (9 CH_{Ar}), 118.6 (CH_{2-All}), 82.5 (C_{tBu}), 62.2 (CHN), 48.3 (CH_{2-All}), 36.6 (CH_{2Ph}), 27.6 (3 CH_{3-tBu}). IR (neat) 3299, 3030, 1731, 1530, 1349, 1164, 930 cm⁻¹. Anal. Calcd. for C₂₂H₂₆N₂O₆S: C, 59.18; H, 5.87; N, 6.27. Found: C, 59.22; H, 5.89; N, 6.23.

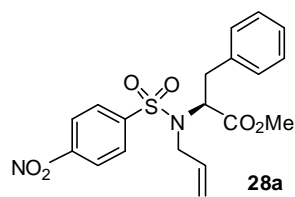

(S)-methyl 2-(N-allyl-4-nitrophenylsulfonamido)-3-phenylpropanoate (28a)

Sulfonamide **27a** (..), **28a** (388 mg, 96%, 5h); $[\alpha]_{D}^{20} = -20.3$ (c 1, CHCl₃). ¹H NMR (300 MHz, CDCl₃) δ 7.78-7.75 (m, 2H), 7.78-7.75 (m, 2H), 7.27-7.21 (m, 5H), 5.76-5.63 (m, 1H), 5.24 (dd, 1H, *J* = 17.4, 1.2), 5.14 (dd, 1H, *J* = 9.9, 1.2), 4.92 (dd, 1H, *J* = 8.7, 6.9), 4.01 (dd, 1H, *J* = 16.2, 6.6), 3.89 (dd, 1H, *J* = 16.5, 6.3), 3.60 (s, 3H), 3.39 (dd, 1H, *J* = 14.4, 6.3), 3.02 (dd, 1H, *J* = 14.4, 9.0). ¹³C NMR (75 MHz, CDCl₃) δ 170.3 (CO), 149.6, 145.7, 136.4 (3 C_{Ar}), 133.4 (CH_{All}), 129., 128.5, 126.8, 123.7 (9 CH_{Ar}), 118.8 (CH_{2-All}), 61.3 (CHN), 52.1 (OCH₃), 48.4 (CH_{2-All}), 36.6 (CH_{2Ph}). IR (neat) 3299, 3030, 1731, 1530, 1349, 1164, 930 cm⁻¹. Anal. Calcd. for C₁₉H₂₀N₂O₆S: C, 56.42; H, 4.98; N, 6.93. Found:

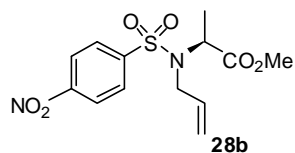

(S)-methyl 2-(N-allyl-4-nitrophenylsulfonamido)propanoate (28b).

Sulfonamide **27b**, 288 mg, ; *N*-allyl sulphonamide **28b** (299 mg, 91%, 3 h); FCC - AcOEt/hexane (1:2); yellow wax, $[\alpha]_{D}^{20} = -47.3$ (c 1.1, CHCl₃). ¹H NMR (300 MHz, CDCl₃) δ 8.31-8.28 (m, 2H), 8.00-7.97 (m, 2H), 5.80-5.67 (m, 1H), 5.17 (dd, 1H, *J* = 17.1, 1.5), 5.09 (d, 1H, *J* = 8.7), 4.70-4.63 (m, 1H), 3.94 (dd, 1H, *J* = 16.5, 5.7), 3.80 (dd, 1H, *J* = 16.5, 6.3), 3.53 (s, 3H), 1.43 (d, 3H, *J* = 7.2). ¹³C NMR (50 MHz, CDCl₃) δ 171.3 (CO), 150.0 (C_{Ar}NO₂), 145.9 (C_{Ar}SO₂), 134.2 (CH_{All}), 128.7, 124.1 (4 CH_{Ar}), 118.4 (CH_{2all}), 55.6, 52.3 (2 CH), 48.4 (CH_{2all}), 16.8 (CH₃). Anal. Calcd. for C₁₃H₁₆N₂O₆S: C, 47.55; H, 4.91; N, 5.83. Found:

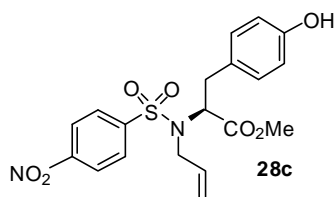

(S)-methyl 2-(N-allyl-4-nitrophenylsulfonamido)-3-(4-hydroxyphenyl)propanoate (28c)

Sulfonamide **27c** 420 mg, **28c** (370, 88%, 24h); $[\alpha]_{D}^{20} = -47.3$ (c 1.1, CHCl₃). ¹H NMR (300 MHz, CDCl₃) δ 8.24-8.19 (m, 2H), 7.79-7.74 (m, 2H), 7.06-7.02 (m, 2H), 6.74-6.70 (m, 2H), 5.72-5.59 (m, 1H), 5.26-5.10 (m, 2H), 4.81 (dd, 1H, *J* = 8.9, 6.5), 3.94-3.83 (m, 2H), 3.59 (s, 3H), 3.28 (dd, 1H, *J* = 14.4, 6.5), 2.92 (dd, 1H, *J* = 14.4, 8.9). ¹³C NMR (75 MHz, CDCl₃) δ 170.7 (CO), 155.0, 149.7, 145.8, 128. (4 C_{Ar}), 133.4 (CH_{All}), 130.3, 128.6, 124.4, 115.5 (8 CH_{Ar}), 119.1 (CH_{2-All}), 61.7 (OCH₃), 52.3 (CHN), 48.5 (CH_{2-All}), 35.2 (CH_{2Ph}).. Anal. Calcd. for C₁₉H₂₀N₂O₇S: C, 54.28; H, 4.79; N, 6.66. Found

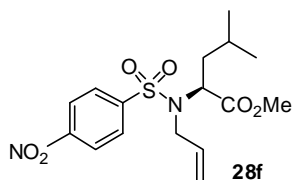

(S)-methyl 2-(N-allyl-4-nitrophenylsulfonamido)-4-methylpentanoate (28f)

Sulfonamide **27f** 330, **28f** (348, 94%, 16h); $[\alpha]_{\text{D}}^{20} = -66.9$ (*c* 1, CHCl_3). $^1\text{H NMR}$ (300 MHz, CDCl_3) δ 8.31-8.27 (m, 2H), 7.99-7.95 (m, 2H), 5.94-5.75 (m, 1H), 5.16 (dd, 1H, $J = 17.1, 1.2$), 5.09 (dd, 1H, $J = 10.2, 1.2$), 4.63 (dd, 1H, $J = 9.3, 5.5$), 3.94 (dd, 1H, $J = 16.7, 5.5$), 3.77 (dd, 1H, $J = 16.6, 7.4$), 3.45 (s, 3H), 1.71-1.61 (m, 1H), 0.94 (d, 3H, $J = 6.0$), 0.88 (dd, 1H, $J = 6.0$). $^{13}\text{C NMR}$ (75 MHz, CDCl_3) δ 171.2 (CO), 149.9, 145.6 (2 C_{Ar}), 134.7 (CH_{AlI}), 134.6, 128.7 (4 CH_{Ar}), 118.0 ($\text{CH}_{2-\text{AlI}}$), 58.4 (CHN), 52.0 (CH_3), 48.4 ($\text{CH}_{2-\text{AlI}}$), 38.7 (CH_2Ph), 24.1 (CH), 22.5, 21.1 (2 CH_3). Anal. Calcd. for $\text{C}_{16}\text{H}_{22}\text{N}_2\text{O}_6\text{S}$: C, 51.88; H, 5.99; N, 7.56. Found

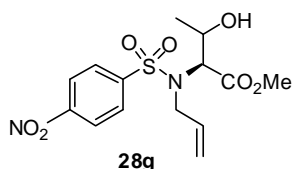

(2S)-methyl 2-(N-allyl-4-nitrophenylsulfonamido)-3-hydroxybutanoate (28g)

Sulfonamide **27f** 318 mg, **28g** (315, 88%, 24h); $[\alpha]_{\text{D}}^{20} = -63.6$ (*c* 1, CHCl_3). $^1\text{H NMR}$ (300 MHz, CDCl_3) δ 8.35-8.32 (m, 2H), 8.04-8.01 (m, 2H), 5.92-5.80 (m, 1H), 5.22 (dd, 1H, $J = 17.4, 1.2$), 5.16 (dd, 1H, $J = 10.2, 1.2$), 4.47 (d, 1H, $J = 5.7$), 4.40-4.37 (m, 1H), 4.10 (dd, 1H, $J = 16.5, 5.1$), 3.99 (dd, 1H, $J = 16.5, 7.2$), 2.22 (d, 1H, $J = 1.5$), 1.32 (s, 3H, $J = 6.3$). $^{13}\text{C NMR}$ (75 MHz, CDCl_3). Anal. Calcd. for $\text{C}_{14}\text{H}_{18}\text{N}_2\text{O}_7\text{S}$: C, 46.92; H, 5.06; N, 7.82. Found

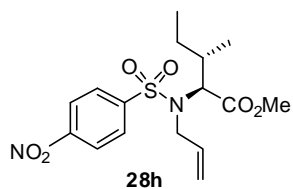

(2S,3S)-methyl 2-(N-allyl-4-nitrophenylsulfonamido)-3-methylpentanoate (28h)

Sulfonamide **27h**, 331 mg; **28h** (370 mg, 99%, 1.5 h); FCC - AcOEt/hexane (1:2); pale yellow wax, $[\alpha]_{\text{D}}^{20} = -105.0$ (*c* 1.1, CHCl_3). $^1\text{H NMR}$ (300 MHz, CDCl_3) δ 8.29-8.26 (m, 2H), 7.97-7.94 (m, 2H), 5.77-5.67 (m, 1H), 5.16 (dd, 1H, $J = 17.4, 1.5$), 5.06 (d, 1H, $J = 10.2$), 4.19 (d, 1H, $J = 10.5$), 4.03 (dd, 1H, $J = 16.2, 7.5$), 3.88 (dd, 1H, $J = 16.2, 3.3$), 3.40 (s, 3H), 1.87-1.84 (m, 1H), 1.69-1.61 (m, 1H), 1.11-1.04 (m, 1H), 0.85 (t, 3H, $J = 7.2$), 0.82 (d, 3H, $J = 6.6$). $^{13}\text{C NMR}$ (75 MHz, CDCl_3) δ 170.5 (CO), 149.9 (C_{ArNO_2}), 145.6 (C_{ArSO_2}), 134.4 (CH_{AlI}), 128.7, 123.8 (4 CH_{Ar}), 118.1 ($\text{CH}_{2\text{all}}$), 64.5 (CHN), 51.4 (OMe), 47.9 ($\text{CH}_{2\text{all}}$), 34.2 (CH_{sBu}); 25.0 ($\text{CH}_{2-\text{sBu}}$), 15.2, 10.3 (2 $\text{CH}_{3-\text{sBu}}$). IR (nujol) 3299, 3030, 2948, 1465, 1731, 1530, 1349, 1164, 930 cm^{-1} . Anal. Calcd. for $\text{C}_{16}\text{H}_{22}\text{N}_2\text{O}_6\text{S}$: C, 51.88; H, 5.99; N, 7.56. Found

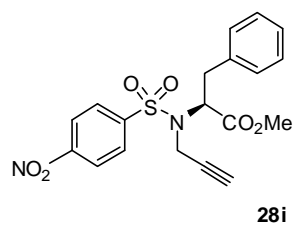

(S)-methyl 2-(4-nitro-N-(prop-2-ynyl)phenylsulfonamido)-3-phenylpropanoate (28i)

28i (382, 95%, 5h); $[\alpha]_{\text{D}}^{20} = -29.1$ (*c* 1.2, CHCl_3). ^{13}C NMR (75 MHz, CDCl_3) δ 170.1 (CO), 149.9, 145.5, 136.2 (3 $\text{C}_{\text{Ar}}\text{CH}_2$), 129.2, 128.8, 128.6, 127.1, 123.7 (9 CH_{Ar}), 73.7 (CH_{prop}), 61.8 (CHN), 52.4 (OCH₃), 36.1, 34.4 (2 CH₂). Anal. Calcd. for $\text{C}_{19}\text{H}_{18}\text{N}_2\text{O}_6\text{S}$: C, 56.71; H, 4.51; N, 6.96. Found:

Rearrangement of *N*-alkyl-4-nitrophenylsulfonamido ester 29 a-m under homogeneous conditions. General procedure:

To a solution of sulfonamide (1 mmol) in dry DME (4 mL), **DBU** (4 mmol) in DME (1mL) was added and the mixture was stirred at 25 °C until completion (TLC control). The solution was then diluted with AcOEt (10 mL), washed with aqueous 5% citric acid (3×10 mL), saturated NaHCO₃ solution (2×10 mL), and brine (10 mL). The organic phase was dried over MgSO₄, filtered, and concentrated under reduced pressure (RV), giving the sultam product **29a-m**.

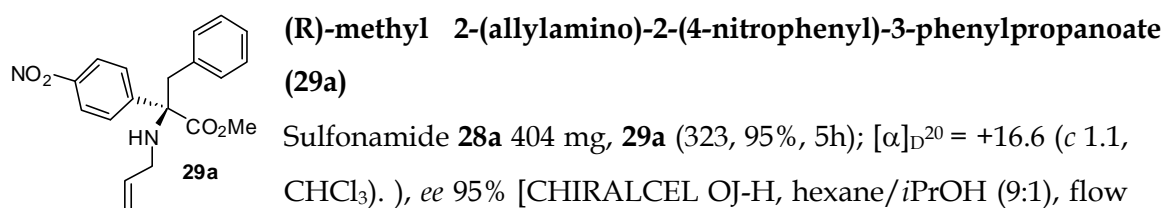

Sulfonamide **28a** 404 mg, **29a** (323, 95%, 5h); [α]_D²⁰ = +16.6 (c 1.1, CHCl₃).), *ee* 95% [CHIRALCEL OJ-H, hexane/*i*PrOH (9:1), flow rate 1 mL/min, P 32 bar, *t*₁ 22.129, *t*₂ 27.099]. ¹H NMR (300 MHz, CDCl₃) δ 8.13-8.10 (m, 2H), 7.54-7.51 (m, 2H), 7.18-7.14 (m, 3H), 6.89-6.85 (m, 2H), 5.97-5.84 (m, 1H), 5.25 (dd, 1H, *J* = 17.4, 1.8), 5.12 (dd, 1H, *J* = 10.2, 1.7), 3.75 (s, 3H), 3.38 (d, 1H, *J* = 13.5), 3.33 (d, 1H, *J* = 13.5), 3.20-3.03 (ddt, 1H, *J* = 16.5, 6.9, 1.5), 3.32 (dd, 1H, *J* = 14.1, 6.6), 2.97 (dd, 1H, *J* = 14.4, 8.7), 1.33 (s, 9H). ¹³C NMR (75 MHz, CDCl₃) δ 173.9 (CO), 149.6, 147.2, 135.4 (3C_{Ar}), 133.4 (CH_{All}), 129.0, 128.8, 128.5, 126.8, 123.8 (9 CH_{Ar}), 118.8 (CH_{2-All}), 72.3(C), 67.8 (CH₃), 45.9 (CH_{2-All}), 37.2 (CH_{2-Ph}). IR (neat) 3299, 3030, 1731, 1530, 1349, 1164, 930 cm⁻¹. Anal. Calcd. for C₁₉H₂₀N₂O₄: C, 67.05; H, 5.92; N, 8.23. Found:

(R)-methyl 2-(allylamino)-2-(4-nitrophenyl)propanoate (29b)

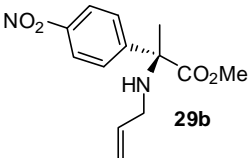

Sulfonamide **28b** 328 mg, **29b** (264, 99%, 5h), *ee* 55% [CHIRALPACK AD, hexane/*i*PrOH (8:2), flow rate 1 mL/min, P 21 bar, *t*₁ 5.965, *t*₂ 6.931]. ¹H NMR (300 MHz, CDCl₃) δ 8.34-8.31 (m, 2H), 7.68-7.65 (m, 2H), 5.99-5.88 (m, 1H), 5.23 (dd, 1H, *J* = 17.2, 1.2), 5.11 (dd, 1H, *J* = 10.2, 1.1), 3.76 (s, 3H), 3.13 (dd, 1H, *J* = 15.3, 7.3), 3.13 (dd, 1H, *J* = 15.3, 7.3), 3.08 (dd, 1H, *J* = 14.1, 6.7), 1.69 (s, 3H). ¹³C NMR (75 MHz, CDCl₃) IR (neat) 3299, 3030, 1731, 1530, 1349, 1164, 930 cm⁻¹. Anal. Calcd. for C₁₃H₁₆N₂O₄: C, 59.08; H, 6.10; N, 10.60. Found:

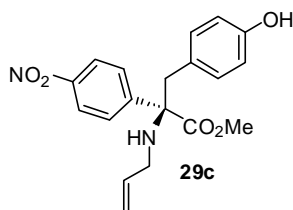

(R)-methyl 2-(allylamino)-3-(4-hydroxyphenyl)-2-(4-nitrophenyl)propanoate (29c)

Sulfonamide **28c** 420 mg, **29c** (303, 85%, 5h); $[\alpha]_{D^{20}} = -20.3$ (*c* 1, CHCl₃).), *ee* 81% [CHIRALCEL OJ-H, hexane/*i*PrOH (95:5), flow rate 1 mL/min, P 17 bar, *t*₁ 15.108, *t*₂ 17.125]. ¹H NMR

(300 MHz, CDCl₃) δ 8.13-8.10 (m, 2H), 7.53-7.50 (m, 2H), 6.74-6.71 (m, 2H), 6.64-6.61 (m, 2H), 5.95-5.82 (m, 1H), 5.23 (dd, 1H, *J* = 17.1, 1.4), 5.11 (dd, 1H, *J* = 10.2, 1.4), 3.75 (s, 3H), 3.32 (s, 2H), 3.13 (dd, 1H, *J* = 13.4, 5.7), 3.03 (dd, 1H, *J* = 13.9, 5.5). ¹³C NMR (75 MHz, CDCl₃) δ 173.4 (CO), 154.8, 147.2, 130.4, 126.9 (4 C_{Ar}), 135.9 (CH_{All}), 131.5, 126.9, 123.1, 115.1 (8 CH_{Ar}), 116.0 (CH_{2-All}), 70.0 (C), 52.3 (OCH₃), 46.3 (CH_{2-All}), 42.8 (CH_{2Ph}).. Anal. Calcd. for C₁₉H₂₀N₂O₅: C, 64.04; H, 5.66; N, 7.86: Found:

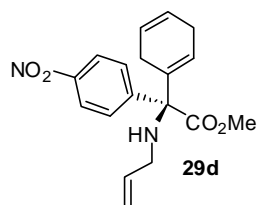

(R)-methyl 2-(allylamino)-2-(cyclohexa-1,4-dienyl)-2-(4-nitrophenyl)acetate (29d)

Yellow oil, **29d** (84%, 5h); $[\alpha]_{D^{20}} = -4.1$ (*c* 1, CHCl₃).), *ee* 81% [CHIRALCEL OJ-H, hexane/*i*PrOH (95:5), flow rate 1 mL/min, P 17 bar, *t*₁ 15.108, *t*₂ 17.125]. ¹H NMR (300 MHz, CDCl₃) δ 8.16-

8.13 (m, 2H), 7.84-7.82 (m, 2H), 7.76-7.74 (m, 4H), 6.00--5.85 (m, 2H), 5.253 (dd, 1H, *J* = 17.1, 1.2), 5.12 (dd, 1H, *J* = 10.2, 1.2), 3.79 (s, 3H), 2.99-2.77 (m, 4H). ¹³C NMR (75 MHz, CDCl₃) IR (neat) 3299, 3030, 1731, 1530, 1349, 1164, 930 cm⁻¹. Anal. Calcd. for C₁₈H₂₀N₂O₄: C, 65.84; H, 6.14; N, 8.53: Found:

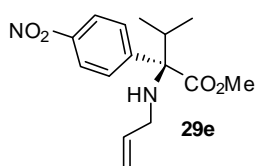

(R)-methyl 2-(allylamino)-3-methyl-2-(4-nitrophenyl)butanoate (29e)

Sulfonamide **28e** 356 mg, **29e** (92%, 48h); $[\alpha]_{\text{D}}^{20} = -20.3$ (*c* 1, CHCl_3).), *ee* 90% [CHIRALPACK AD, hexane/*i*PrOH (8:2), flow rate 1 mL/min, P 22 bar, t_1 4.834, t_2 6.204]. ^1H NMR (300 MHz, CDCl_3) δ . IR (neat) 3299, 3030, 1731, 1530, 1349, 1164, 930 cm^{-1} . Anal. Calcd. for $\text{C}_{15}\text{H}_{20}\text{N}_2\text{O}_4$: C, 61.63; H, 6.90; N, 9.58; Found:

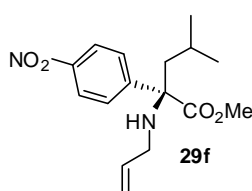

(R)-methyl 2-(allylamino)-4-methyl-2-(4-nitrophenyl)pentanoate (29f)

29f (251, 82%, 48h); $[\alpha]_{\text{D}}^{20} = -25.3$ (*c* 1, CHCl_3).), *ee* 80% [CHIRALCEL OJ-H, hexane/*i*PrOH (95:5), flow rate 1 mL/min, P 17 bar, t_1 15.108, t_2 17.125]. ^1H NMR (300 MHz, CDCl_3) δ 8.17-8.14 (m, 2H), 7.73-7.70 (m, 2H), 5.95-5.83 (m, 1H), 5.243 (dd, 1H, $J = 17.1, 1.2$), 5.09 (dd, 1H, $J = 10.2, 1.2$), 3.79 (s, 3H), 3.01-2.87 (m, 2H), 2.13-2.03 (m, 1H), 1.90-1.77 (m, 1H), 0.85-0.80 (m, 6H), 0.47-0.31 (m, 1H) Anal. Calcd. for $\text{C}_{16}\text{H}_{22}\text{N}_2\text{O}_4$: C, 62.73; H, 7.24; N, 9.14; Found

(2S)-methyl 2-(allylamino)-3-hydroxy-2-(4-nitrophenyl)butanoate (29g)

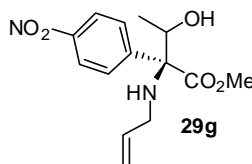

29g (82%, 48h); $[\alpha]_{\text{D}}^{20} = -20.3$ (*c* 1, CHCl_3).), *de* <99% ^1H NMR ^{13}C NMR (75 MHz, CDCl_3) δ 170.4 (CO), 149.96, 135.7 (2C_{Ar}), 135.7 (CH_{AlI}), 128.3, 123.9 (4 CH_{Ar}), 109.5 ($\text{CH}_2\text{-AlI}$), 68.0 (C), 67.9, 61.5 (CH_3 , CHO), 52.4 ($\text{CH}_2\text{-AlI}$), 20.0 (CH_3). Anal. Calcd. for

$\text{C}_{16}\text{H}_{22}\text{N}_2\text{O}_4$: C, 62.73; H, 7.24; N, 9.14; Found

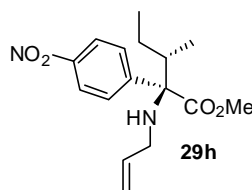

(2R,3S)-methyl 2-(allylamino)-3-methyl-2-(4-nitrophenyl)pentanoate (29h)

29h (242, 79%, 48h); $[\alpha]_{\text{D}}^{20} = -14.4$ (*c* 1, CHCl_3).), *de* 99%. ^1H NMR (300 MHz, CDCl_3) δ 8.19-8.16 (m, 2H), 7.70-7.67 (m, 2H), 5.96-5.83 (m, 1H), 5.25 (dd, 1H, $J = 17.1, 1.2$), 5.09 (dd, 1H, $J = 10.2, 1.2$), 3.69 (s, 3H), 3.01-2.89 (m, 2H), 2.13 (dd, 1H, $J = 14.4, 6.6$), 2.04 (bs, 1H), 2.00 (dd, 1H, $J = 14.4, 5.4$), 1.64-1.51 (m, 1H), 0.85(d, 3H, $J = 6.8$), 0.73(d, 3H, $J = 6.8$). ^{13}C NMR (75 MHz, CDCl_3) δ 174.3 (CO), 149.3, 147.2 (2C_{Ar}), 136.1 (CH_{AlI}), 127.8, 123.3, (4 CH_{Ar}), 115.8 ($\text{CH}_2\text{-AlI}$), 68.0 (C), 52.3

(CH₃), 46.0, 44.6 (CH_{2-All}, CH₂), 24.3, 23.7, 23.4 (3 CH₃) Anal. Calcd. for C₁₆H₂₂N₂O₄: C, 62.73; H, 7.24; N, 9.14: Found

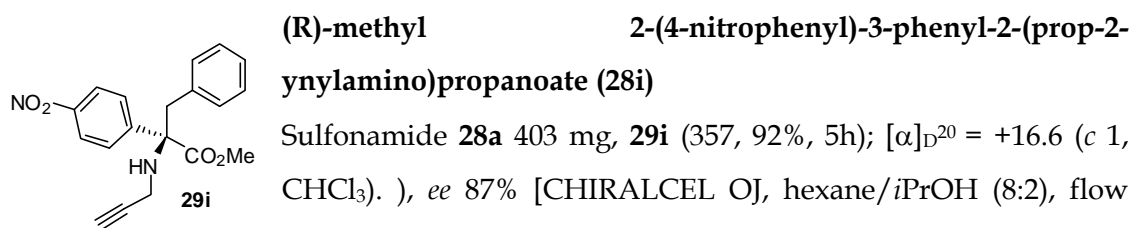

Sulfonamide **28a** 403 mg, **29i** (357, 92%, 5h); [α]_D²⁰ = +16.6 (*c* 1, CHCl₃).), *ee* 87% [CHIRALCEL OJ, hexane/*i*PrOH (8:2), flow rate 1 mL/min, P 37 bar, *t*₁ 30.885, *t*₂ 43.615]. ¹H NMR (300 MHz, CDCl₃) δ 8.14-8.11 (m, 2H), 7.58-7.55 (m, 2H), 7.20-7.18 (m, 3H), 6.92-6.89 (m, 2H), 3.77 (s, 3H), 3.42-3.35 (m, 3H), 3.29 (dd, 1H, *J* = 16.5, 2.4), 2.26 (bs, 1H), 2.22 (t, 1H, *J* = 2.4). ¹³C NMR (75 MHz, CDCl₃). IR (neat) 3299, 3030, 1731, 1530, 1349, 1164, 930 cm⁻¹. Anal. Calcd. for C₁₉H₁₈N₂O₄: C, 67.44; H, 5.36; N, 8.28. Found:

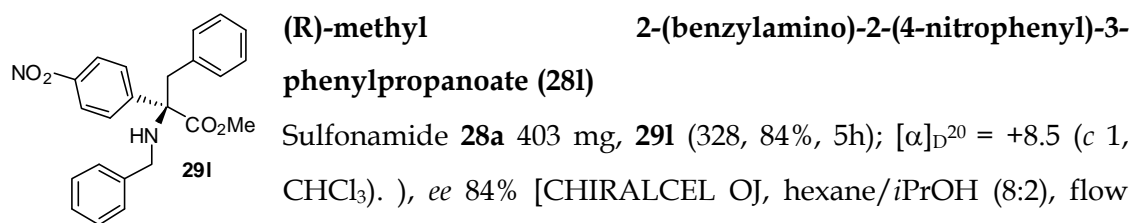

Sulfonamide **28a** 403 mg, **29l** (328, 84%, 5h); [α]_D²⁰ = +8.5 (*c* 1, CHCl₃).), *ee* 84% [CHIRALCEL OJ, hexane/*i*PrOH (8:2), flow rate 1 mL/min, P 37 bar, *t*₁ 35.018, *t*₂ 44.598]. ¹H NMR (300 MHz, CDCl₃) δ 8.14-8.11 (m, 2H), 7.62-7.59 (m, 2H), 7.35-7.16 (m, 10H), 6.91-6.90 (m, 2H), 3.79 (s, 3H), 3.75 (d, 1H, *J* = 12.6), 3.61 (dd, 1H, *J* = 12.6), 3.43 (s, 2H), 2.12 (bs, 1H). ¹³C NMR (75 MHz, CDCl₃). IR (neat) 3299, 3030, 1731, 1530, 1349, 1164, 930 cm⁻¹. Anal. Calcd. for C₂₃H₂₂N₂O₄: C, 70.75; H, 5.68; N, 7.17. Found:

General method for the preparation of β -tosylamido alcohols 31

A heterogeneous mixture of TsNH₂ (342 mg, 2 mmol), TEBA (23 mg, 0.1 mmol) and epoxide (1 mmol) solution in anhydrous dioxane (0.5 mL) and anhydrous K₂CO₃ (14 mg, 0.1 mmol), was magnetically stirred at 90 °C until no starting material **1** was detectable (TLC analysis). After cooling, the crude product was diluted with DCM (10 mL), filtered through celite, the solvent was evaporated under reduced pressure and the residue was purified by flash column chromatography on silica gel (230-400 mesh).

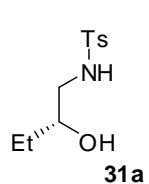

(R)-N-(2-hydroxybutyl)-4-methylbenzenesulfonamide (**31a**)

white solid y 77%; mp 75.4-76-7°C; [α]_D²⁰ = -24.4 (*c* 1, CHCl₃). ¹H NMR 300 MHz (CDCl₃) δ 7.74 (d, 2H, *J* = 8.3 Hz), 7.31 (d, 1H, *J* = 8.3 Hz), 4.82 (t, 1 H, *J* = 0.9 Hz), 3.62-3.60 (m, 1 H), 3.12-3.04 (m, 1H), 2.82-2.73 (m, 1H), 2.42 (s, 3H), 1.90-1.91 (d, 1H, *J* = 4.5 Hz), 1.56-1.41 (m, 2H), 0.90 (t, 3H, *J* = 7.5 Hz). ¹³C NMR 300 MHz (CDCl₃) δ , 137.12 (1C), 130.16 (2CH), 127.50 (2CH), 72.22 (1CH), 48.77 (1CH₂), 56.64 (1CH₂), 27.88 (1CH₂), 21.92 (1CH₃), 10.17(1CH₃). Anal. calcd for C₁₁H₁₇NO₃S: C, 61.83; H, 5.88; N, 4.81. Found

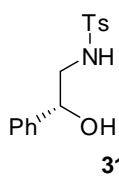

(R)-N-(2-hydroxy-2-phenylethyl)-4-methylbenzenesulfonamide (**31b**)

white solid y 66%; mp 94.8-95°C; [α]_D²⁰ -70.5 (*c* 1, CHCl₃). ¹H NMR (CDCl₃, 300 MHz) δ 7.72 (d, 2H, *J* = 8.4 Hz), 7.32-7.25 (m, 7H), 5.00 (q, 1H, *J* = 4.2 Hz), 4.79 (dt, 1H, *J* = 3.6, 8.5 Hz), 3.20 (ABMX, 2H, *J* = 4.2, 8.5, 12.6, 40.5 Hz), 2.52 (d, 1H, *J* = 3.6), 2.41 (s, 3H). ν_{\max} (Nujol) 3401, 3149, 1918, 1662, 1598, 1318, 1148, 1098, 1088, 1065 cm⁻¹ Anal. calcd for C₁₅H₁₇NO₃S: C, 61.83; H, 5.88; N 4.81. Found: C, 61.91; H, 5.92; N, 4.78.

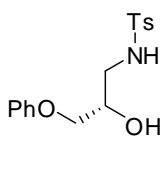

(S)-N-(2-hydroxy-3-phenoxypropyl)-4-methylbenzenesulfonamide

2 h; AcOEt-PE 1:1. **3a**, 292.5 mg, 91%; white solid, mp 63 °C; ν_{\max} (Nujol) 3479, 3245, 1599, 1586, 1499, 1417, 1332, 1310, 1253, 1154, 883, 1078, 1046, 1023, 952 813, 750 cm⁻¹; δ_{H} (300 MHz, CDCl₃) 7.75 (2 H, d, *J* 8.3 Hz, Ts), 7.32-7.25 (4 H, m, Ar), 6.97 (1 H, t, *J* 7.4 Hz, Ph), 6.85 (2 H, d, *J* 8.1 Hz, Ph), 5.12 (1 H, dd, *J* 6.3, NH), 4.11-4.07 (1 H, m, CHOH), 3.96-3.91 (2 H, m, CH₂OPh), 3.25 (1 H, ddd, *J* 3.9, *J* 7.0, 13.2 Hz, CH_aH_bN), 3.13-3.05 (1 H, m, CH_aH_bN), 2.64 (1 H, d, *J* 4.6 Hz,

OH), 2.43 (3 H, s, ArMe). Anal. calcd for C₁₆H₁₉NO₄S: C, 59.79; H, 5.96; N, 4.36. Found: C, 59.80; H, 5.93; N, 4.39.

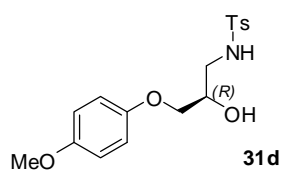

(R)-N-(2-hydroxy-3-(4-methoxyphenoxy)propyl)-4-methylbenzenesulfonamide (31d)

white solid, **31d** y 79%; mp 74.8-75°C; ¹H NMR (CDCl₃, 300 MHz) δ 7.74-7.71 (m, 2H), 7.28-7.25 (m, 2H), 6.67 (s, 4H), 5.28-5.26 (m, 1H), 4.09-4.05 (m, 1H), 3.86(d, 2H, J = 5.3 Hz), 3.74 (s, 3H), 3.17-3.23 (m, 1H), 3.06 (dd, 1H, J = 3.6), 2.40 (s, 3H). ¹³C NMR (75 MHz, CDCl₃) δ 154.3, 152.3, 143.6, 136.7 (4C_{Ar}), 129.9, 127.1, 115.6, 114.7 (8CH_{Ar}), 70.4 (1 CH₂O), 68.7 (1CHOH), 55.7 (1CH₃O), 54.5 (CH₂N), 21.5 (1CH₃).

General procedure for the synthesis of amido diol 37

A heterogeneous mixture of tosylamido alcohol **31** (1.4 mmol), TEBA (23 mg, 0.1 mmol), epoxide (1 mmol) solution in anhydrous dioxane (1.5 mL) and anhydrous alkaline carbonate (0.1 mmol), was magnetically stirred at 90 °C until no starting material **1** was detectable (TLC analysis). After the usual workup, the residue was purified by flash column chromatography on silica gel (230-400 mesh).

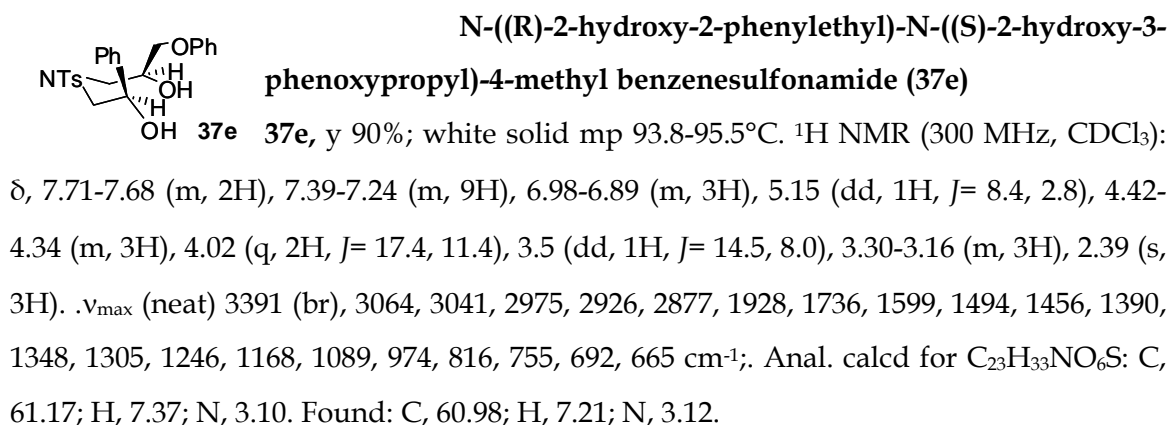
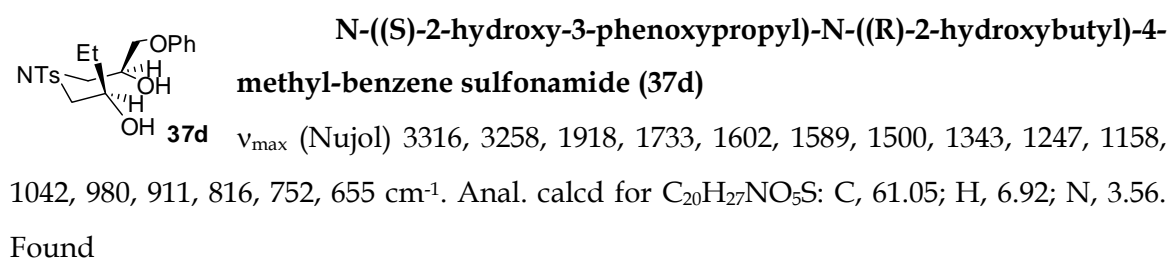
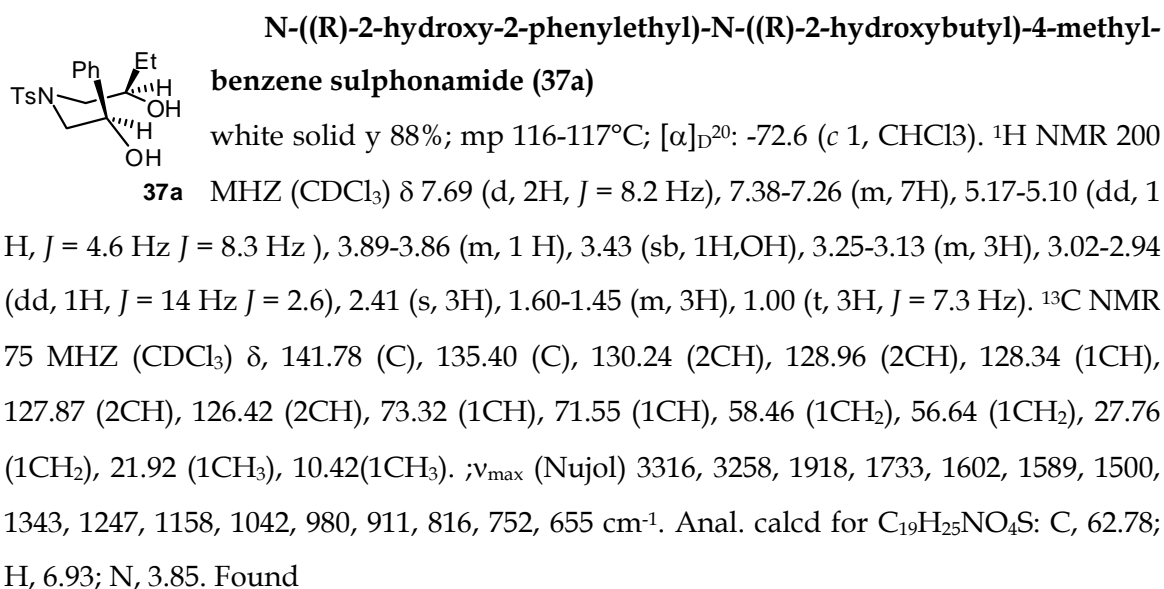

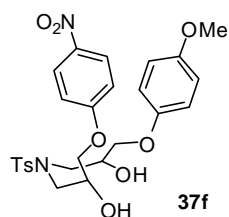

N-(2-hydroxy-3-(4-methoxyphenoxy)propyl)-N-(2-hydroxy-3-(4-nitrophenoxy)propyl)-4-methylbenzenesulfonamide (37f)

37f, wax; $^1\text{H NMR}$ (300 MHz, CDCl_3): δ , 8.12-8.08 (m, 2H), 7.72-7.67 (m, 2H), 7.33-7.26 (m, 2H), 6.92-6.88(m, 2H), 6.74 (s, 4H), 4.49-4.41 (m, 1H), 4.12-4.04 (m, 1H), 3.91-3.88 (m, 1H), 3.73 (s, 1H), 3.66-3.56 (m, 1H), 3.46-3.20-3.07 (m, 1H), 2.42 (s, 3H). $^{13}\text{C NMR}$ (75 MHz, CDCl_3): δ 163.2, 158.6, 145.7, 144.9, 142.3, 134.7, 133.6 (7C_{Ar}), 134.7, 133.6, 130.5, 130.2, 130.0, 128.6, 127.9, 126.1, 121.9, 114.9 (17 CH_{Ar}), 77.9 (CHOTs), 69.7 (CHOH), 69.9, 67.7 (2 CH_2OPh), 54.8, 51.8 (2 CH_2N), 22.0, 21.9 (2 CH_3). Anal. calcd for $\text{C}_{26}\text{H}_{30}\text{N}_2\text{O}_9\text{S}$: C, 57.13; H, 5.53; N, 5.13. Found: C, 60.98; H, 7.21; N, 3.12.

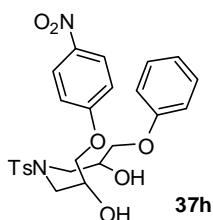

N-(2-hydroxy-3-(4-nitrophenoxy)propyl)-N-(2-hydroxy-3-phenoxypropyl)-4-methylbenzenesulfonamide (37h)

37h (86%, 16 h); FCC - AcOEt/hexane (1:2); yellow oil, $[\alpha]_{\text{D}}^{20} = -108.5$ (c 1, CHCl_3), ee 61% [CHIRALPAK AD, hexane/ i PrOH (8:2), flow rate 1 mL/min, P 17 bar, t_1 5.73, t_2 6.85]. $^1\text{H NMR}$ (300 MHz, CDCl_3) δ $^1\text{H NMR}$ (300 MHz, CDCl_3) δ 8.21-8.17 (m, 2H), 7.74-7.70 (m, 2H), 7.36-7.25 (m, 5H), 7.01-6.86 (m, 4H), 4.51-4.41 (m, 2H), 4.11 (d, 2H, $J = 5.1$), 4.01-3.97 (m, 2H), 3.64 (dd, 1H, $J = 5.6, 3.04$), 3.56 (dd, 1H, $J = 5.6, 3.04$), 3.26 (dd, 1H, $J = 8.9, 1.8$), 3.18 (dd, 1H, $J = 8.6, 1.6$), 2.44 (s, 3H). Anal. calcd for $\text{C}_{25}\text{H}_{28}\text{N}_2\text{O}_8\text{S}$: C, 58.13; H, 5.46; N, 5.42. Found: C, 60.98; H, 7.21; N, 3.12.

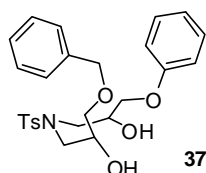

N-(3-(benzyloxy)-2-hydroxypropyl)-N-(2-hydroxy-3-phenoxypropyl)-4-methylbenzenesulfonamide (37l)

37l, wax; $^1\text{H NMR}$ (300 MHz, CDCl_3): δ , 7.72-7.68 (m, 2H), 7.35-7.23 (m, 8H), 6.99-6.87 (m, 3H), 4.54(s, 2H), 4.35-4.18 (m, 2H), 4.02-3.98 (m, 3H), 3.72 (bs, 1H), 3.54-3.51 (m, 2H), 3.35-3.23 (m, 4H), 2.42 (s, 3H). $^{13}\text{C NMR}$ (75 MHz, CDCl_3): δ 163.2, 158.6, 145.7, 144.9, 142.3, 134.7, 133.6 (7C_{Ar}), 134.7, 133.6, 130.5, 130.2, 130.0, 128.6, 127.9, 126.1, 121.9, 114.9 (17 CH_{Ar}), 77.9 (CHOTs), 69.7 (CHOH), 69.9, 67.7 (2 CH_2OPh), 54.8, 51.8 (2 CH_2N), 22.0, 21.9 (2 CH_3). Anal. calcd for $\text{C}_{26}\text{H}_{31}\text{NO}_6\text{S}$: C, 64.31; H, 6.43; N, 2.88. Found: C, 60.98; H, 7.21; N, 3.12.

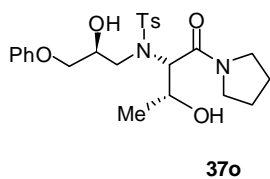

N-((2S,3R)-3-hydroxy-1-oxo-1-(pyrrolidin-1-yl)butan-2-yl)-N-((S)-2-hydroxy-3-phenoxypropyl)-4-methylbenzenesulfonamide (37o)

White wax, **37o**, y 77%; $[\alpha]_{\text{D}}^{20}$: -4.14 (c 1, CHCl_3). $^1\text{H NMR}$ 300 MHz (CDCl_3) δ 7.72-7.68 (m, 2H), 7.30-7.22 (m, 4H), 6.99-6.84 (m, 3H), 4.61-4.42 (m, 1H),

4.33 (d, 1H, $J = 8.9$), 4.22-4.09 (m, 2H), 4.01 (d, 1H, $J = 9.5, 3.6$), 3.87-3.79 (m, 2H), 3.61 (dd, 1H, $J = 16.8, 2.1$), 3.58-3.22 (3H), 2.87 (bs, 1H), 2.40 (s, 3H), 1.97-1.80 (m, 4H). (Anal. calcd for $C_{24}H_{32}N_2O_6S$: C, 60.48; H, 6.77; N, 5.88. Found: C,

General procedure for the synthesis of mono sulfonyl derivatives 38

In a flame-dried round flask a tosylamido diol (1 mmol) solution in anhydrous THF(3 ml) was drop-wise to NaH (2 mmol) at 0°C, under nitrogen atmosphere. The reaction mixture was stirred at 0°C until hydrogen evolution ended (30'). After this time the stirring was continued at -80°C and a solution of sulfonyl chloride (1 mmol) in THF (2ml) was added to the suspension. After the disappear of the starting material, the reaction is quenched by NH₄Cl_{sat}; the crude was diluted with DCM, filtered through celite pad and the solvent was evaporated under reduced pressure. The residue was purified by flash column chromatography.

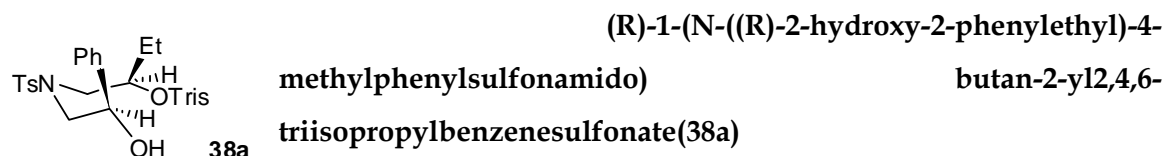

white solid y 72%; mp 71.5-72.8°C; [α]_D²⁰ +13.0 (c 1, CHCl₃); [HPLC: column CHIRALPAK IB Hex/iPr:95/5; flow 0.5 ml/min]. ¹H NMR 300 MHz(CDCl₃) δ 7.69 (d, 2H, J = 8.3 Hz), 7.36-7.25 (m, 9H), 4.99-4.96 (m, 1H), 4.89-4.86 (m, 1 H), 4.16-4.07 (quintetto, 2H), 3.63-3.56 (dd, 1H, J = 6.9 Hz J = 14 Hz), 3.42-3.27 (m, 2H), 3.15-3.09 (m, 1H), 2.92-2.87 (quintetto, 1H), 2.41 (s, 3H), 1.80-1.55(m, 2H), 1.27-1.58 (m, 18H) 0.82(t, 3H, J = 7.4 Hz).¹³C NMR 300 MHz (CDCl₃) δ 153.68(C), 150.28 (C), 144.00 (C), 141.34 (C), 135.20 (C), 129.85 (2CH), 128.55 (2CH), 127.93 (1CH), 127.60 (2CH), 125.95 (2CH), 123.71 (2CH), 81.47 (1CH), 72.63 (1CH), 58.64 (1CH₂), 53.44 (1CH₂), 34.21(1CH), 29.74 (2CH), 24.96 (1CH₂), 24.82 (2CH₃), 24.54 (2CH₃), 23.52 (2CH₃), 21.51 (1CH₃), 9.03(1CH₃). Anal. calcd for C₃₄H₄₇NO₆S₂: C, 64.83; H, 7.52; N, 2.22 Found

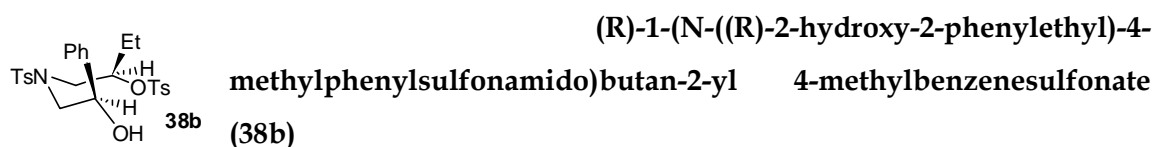

white solid y 57%; mp 119.1-119.8°C; [α]_D²⁰ = +14.4 (c=1 CHCl₃)¹H NMR 300 MHz (CDCl₃) δ 7.78 (d, 2H, Ts, J = 8.2 Hz), 7.69 (d, 2H, Ts, J = 8.2 Hz), 7.32-7.28 (m, Ts Ph, 9H) 4.95-4.88 (dd, 1H, CHPh, J = 3.2, 9.2 Hz), 4.71-4.65 (m, CH₂Et, 1H), 3.53-3.43 (dd, 1H, NCH₂CH₂Et, J= 14.8, 5.8 Hz), 3.36-3.23 (m,CH₂NCH₂ 2H), 3.06-2.97 (dd, 1H, NCH₂CHPh J= 14.8, 3.2 Hz), 2.42 (s, 6H, CH₃Ts), 1.72-1.52(m, 2H, CH₂), 0.73(t, 3H, J= 7.3 Hz).¹³C NMR 75 MHz (CDCl₃) δ , 143.97 (C), 141.27 (C), 135.12 (C), 133.61 (C), 129.46 (2CH),

128.85 (2CH), 128.50 (2CH), 128.33 (1CH), 128.29 (2CH), 128.04 (2CH), 125.90 (2CH), 82.59 (1CH, CHEt), 72.41 (1CH, CHPh), 58.67 (1CH₂,CH₂Et), 53.40 (1CH₂,CH₂Ph), 25.21 (1CH₂), 21.57 (1CH₃, Ts), 21.45 (1CH₃, Ts), 8.90 (1CH₃). Anal. calcd for C₂₀H₂₇NO₆S₂: C, 54.40; H, 6.16; N, 3.17. Found

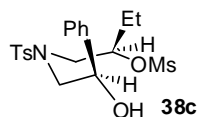

(R)-1-(N-((R)-2-hydroxy-2-phenylethyl)-4-methylphenylsulfonamido)butan-2-yl methanesulfonate (38c)

clear oil y 50% ¹H NMR 200 MHz (CDCl₃) δ 7.69 (d, 2H, J = 8.3 Hz), 7.35-7.25 (m 7H), 4.98-4.93 (dd, 1H, J = 6.4, 9.2 Hz) 4.93-4.89 (m, 1H), 3.36-3.34 (m, 2H), 3.34-3.25 (dd, 1H, J= 14.8, 5.5 Hz), 3.18-3.13 (dd, 1H, J = 3.2, 14.8 Hz), 3.12 (s, 3H), 3.10 (sb, 1H), 2.41 (s, 3H), 1.82-1.74(m, 2H), 0.99(t, 3H, J= 7.3 Hz). Anal. calcd for C₂₀H₂₇NO₆S₂: C, 54.40; H, 6.16; N, 3.17. Found

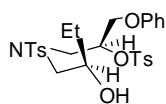

(S)-1-(N-((R)-2-hydroxybutyl)-4-methylphenylsulfonamido)-3-phenoxypropan-2-yl 4-methylbenzenesulfonate (38d)

clear oil y 85%, [α]_D²⁰ +19.5 (c 1, CHCl₃)¹H NMR 300 MHz (CDCl₃) δ 7.81 (d, 2H, J = 8.1 Hz), 7.67 (d, 2H, J = 8.1 Hz), 7.31-7.19 (m, 6H), 6.92 (t, 1H, J = 7.5 Hz), 6.69 (d, 2H, J = 8.1 Hz), 5.19-5.163 (m, 1H), 4.16-4.09 (m, 2H), 4.16-4. (m, 1H), 3.65-3.57 (dd, 1H, J= 6.3, 15.3 Hz), 3.46-3.38 (dd, 1H, J= 6.6, 15.0 Hz), 3.06-2.97 (m, 2H), 2.63 (bs, 1H), 2.41 (s, 6H), 1.40-1.26 (m, 2H), 0.73(t, 3H, J= 7.3 Hz). Anal. calcd for C₂₇H₃₃NO₇S₂: C, 59.21; H, 6.07; N, 2.56. Found

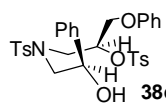

(S)-1-(N-((R)-2-hydroxy-2-phenylethyl)-4-methylphenylsulfonamido)-3-phenoxypropan-2-yl 4-methylbenzenesulfonate (38e)

38e, wax; [α]_D²⁰ -12.0 (c 1.0, CHCl₃). ¹H NMR (300 MHz, CDCl₃): δ = 7.81 (d, 2H, J = 8.3 Hz), 7.69 (d, 2H, J = 8.3 Hz), 7.31-7.20 (m, 11H), 6.94 (t, 1H, J = 7.3 Hz), 6.69 (d, 2H, J = 8.1 Hz), 5.06-5.01 (m, 1H), 4.96 (dd, 1H, J= 9.3, 3.2 Hz), 4.18-4.07 (m, 2H), 3.70-3.63 (dd, 1H, J= 15.3, 6.7 Hz), 3.53-3.46 (dd, 1H, J= 12.2, 6.2 Hz), 3.34-3.26 (dd, 1H, J= 14.7, 9.3 Hz), 3.14-3.08 (dd, 1H, J= 14.7, 3.3 Hz), 2.81 (bs, 1H), 2.41 (s, 6H). ¹³C NMR(75 MHz, CDCl₃): δ = 157.7 (C_{Ar}O), 145.0, 144.1 (2 C_{Ar}Me), 141.0 (C_{Ar}CHOH), 134.5, 133.0 (2 C_{Ar}S), 129.9, 129.7, 129.3, 128.5, 128.1, 127.9, 127.5, 125.8, 121.3, 114.4 (18 CH_{Ar}), 78.4 (OCHPh), 72.4 (CHOTs), 66.5 (CH₂OPh), 58.8 (CH₂N), 51.1 (CH₂N), 21.6, 21.5 (2 CH₃). IR (nujol) 3504, 2924, 1733, 1598, 1243, 1159, 1090, 1045, 917 cm⁻¹ Anal. Calcd for C₃₁H₃₃NO₇S₂: C, 62.50; H, 5.58; N, 2.35. Found: C, 62.44; H, 5.53; N, 2.39.

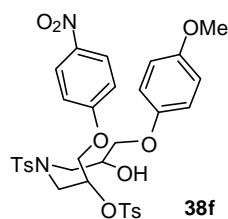

1-(N-(2-hydroxy-3-(4-methoxyphenoxy)propyl)-4-methylphenylsulfonamido)-3-(4-nitrophenoxy)propan-2-yl 4-methylbenzenesulfonate (38f)

38f, wax; $[\alpha]_{\text{D}}^{20}$ -12.0 (*c* 1.0, CHCl_3). $^1\text{H NMR}$ (300 MHz, CDCl_3): δ , 8.13-8.07 (m, 2H), 7.81-7.77 (m, 2H), 7.70-7.66 (m, 2H), 7.35-7.26 (m, 4H), 6.80 (s, 4H), 6.71-6.66 (m, 2H), 5.31-5.25 (m, 1H), 4.38 (dd, 1H, J = 11.2, 2.9 Hz), 4.28-4.17 (m, 2H), 3.94-3.82 (m, 2H), 3.76-3.66 (m, 4H), 3.45-3.34 (m, 2H), 3.18 (dd, 1H, J = 15.1, 8.4 Hz), 2.83 (bs, 1H), 2.41 (s, 6H). $^{13}\text{C NMR-APT}$ (75 MHz, CDCl_3): δ , 163.2, 154.8, 152.8, 145.7, 144.8, 142.2, 134.6, 130.2, (8 C_{Ar}), 130.5, 130.2, 128.6, 128.1, 127.9, 126.1, 115.9, 115.2, 114.9 (16 CH_{Ar}), 77.9 (CHOTs), 69.7 (CHOH), 70.7, 67.5 (2 CH_2OPh), 54.8, 51.7 (2 CH_2N), 22.1, 22.0 (2 CH_3). Anal. Calcd for $\text{C}_{33}\text{H}_{36}\text{N}_2\text{O}_{11}\text{S}_2$: C, 56.56; H, 5.18; N, 4.00. Found: C,

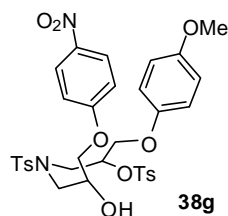

1-(N-(2-hydroxy-3-(4-nitrophenoxy)propyl)-4-methylphenylsulfonamido)-3-(4-methoxyphenoxy)propan-2-yl 4-methylbenzenesulfonate (38g)

38g, wax; $[\alpha]_{\text{D}}^{20}$ -12.0 (*c* 1.0, CHCl_3). $^1\text{H NMR}$ (300 MHz, CDCl_3): δ , 8.19-8.14 (m, 2H), 7.81-7.77 (m, 2H), 7.70-7.66 (m, 2H), 7.36-7.26 (m, 4H), 6.94-6.90 (m, 2H), 6.81-6.70 (m, 2H), 6.67-6.60 (m, 2H), 5.21-5.17 (m, 1H), 4.36-4.26 (m, 1H), 4.09-4.02 (m, 2H), 3.4 (s, 3H), 3.64-3.52 (m, 2H), 3.35-3.30 (m, 2H), 2.43 (s, 6H). $^{13}\text{C NMR-APT}$ (75 MHz, CDCl_3): δ , 163.2, 154.8, 152.8, 145.7, 144.8, 142.2, 134.6, 130.2, (8 C_{Ar}), 130.5, 130.2, 128.6, 128.1, 127.9, 126.9, 115.9, 115.2, 114.9 (16 CH_{Ar}), 78.2 (CHOTs), 69.0 (CHOH), 70.7, 67.5 (2 CH_2OPh), 54.8, 52.1 (2 CH_2N), 22.1, 22.0 (2 CH_3). Anal. Calcd for $\text{C}_{33}\text{H}_{36}\text{N}_2\text{O}_{11}\text{S}_2$: C, 56.56; H, 5.18; N, 4.00. Found: C,

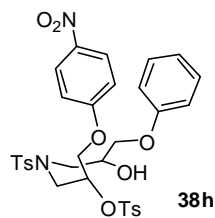

1-(N-(2-hydroxy-3-phenoxypropyl)-4-methylphenylsulfonamido)-3-(4-nitro phenoxy)propan-2-yl 4-methylbenzenesulfonate (38h)

38h, wax; $[\alpha]_{\text{D}}^{20}$ -13.1 (*c* 1.0, CHCl_3). $^1\text{H NMR}$ (300 MHz, CDCl_3): δ = 8.09-8.04 (m, 2H), 7.81-7.77 (m, 2H), 7.60-7.66 (m, 2H), 7.35-7.22 (m, 6H), 6.97 (t, 1H, J = 7.3 Hz), 6.88-6.83 (m, 2H), 6.71-6.66 (m, 2H), 5.32-5.27 (m, 1H), 4.36 (dd, 1H, J = 9.3, 2.7 Hz), 4.28-4.20 (m, 1H), 3.94-3.80 (m, 1H), 3.71 (dd, 1H, J = 12.2, 6.2 Hz), 3.46-3.35 (m, 2H), 3.18 (dd, 1H, J = 14.7, 8.4 Hz), 2.85 (bs, 1H), 2.42 (s, 6H). $^{13}\text{C NMR}$ (75 MHz, CDCl_3): δ 163.2, 158.6, 145.7, 144.9, 142.3, 134.7, 133.6 (7 C_{Ar}),

134.7, 133.6, 130.5, 130.2, 130.0, 128.6, 127.9, 126.1, 121.9, 114.9 (17 CH_{Ar}), 77.9 (CHOTs), 69.7 (CHOH), 69.9, 67.7 (2CH₂OPh), 54.8, 51.8 (2 CH₂N), 22.0, 21.9 (2 CH₃). Anal. Calcd for C₃₂H₃₄N₂O₁₀S₂: C, 57.30; H, 5.11; N, 4.18. Found: C,

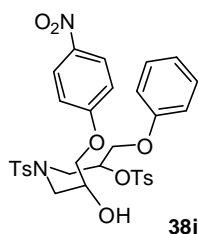

1-(N-(2-hydroxy-3-(4-nitrophenoxy)propyl)-4-methylphenylsulfonamido)-3-phenoxypropan-2-yl 4-methylbenzenesulfonate (38i)

38e, (21%) wax. ¹H NMR (300 MHz, CDCl₃): δ = 8.17-8.14 (m, 2H), 7.81-7.77 (m, 2H), 7.71-7.68 (m, 2H), 7.35-7.16 (m, 7H), 6.96-6.90 (m, 2H), 6.67-6.61 (m, 2H), 5.20-5.15 (m, 1H), 4.34-4.26 (m, 1H), 4.13-4.02 (m, 4H), 3.69 (dd, 1H, *J* = 15.0, 6.6 Hz), 3.51 (dd, 1H, *J* = 15.0, 5.4 Hz), 3.45-3.35 (m, 2H), 2.43 (s, 3H), 2.41 (s, 3H). ¹³C NMR (75 MHz, CDCl₃): δ δ 163.2, 158.6, 145.7, 144.9, 142.3, 134.7, 133.6 (7C_{Ar}), 134.7, 133.6, 130.5, 130.2, 130.0, 128.6, 127.9, 126.1, 121.9, 114.9 (17 CH_{Ar}), 77.9 (CHOTs), 69.7 (CHOH), 69.9, 67.7 (2CH₂OPh), 54.8, 51.8 (2 CH₂N), 22.0, 21.9 (2 CH₃). Anal. Calcd for C₃₂H₃₄N₂O₁₀S₂: C, 57.30; H, 5.11; N, 4.18. Found: C,

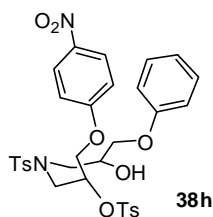

1-(N-(2-hydroxy-3-phenoxypropyl)-4-methylphenylsulfonamido)-3-(4-nitro phenoxy)propan-2-yl 4-methylbenzenesulfonate (38h)DIAST

38h, wax; [α]_D²⁰ -12.0 (*c* 1.0, CHCl₃). ¹H NMR (300 MHz, CDCl₃): δ, 8.09-8.06 (m, 2H), 7.80-7.77 (m, 2H), 7.70-7.68 (m, 2H), 7.35-7.26 (m, 4H), 6.96 (t, 1H, *J* = 7.3 Hz), 6.86-6.83 (m, 2H), 6.70-6.67 (m, 2H), 5.33-5.25 (m, 1H), 4.36 (dd, 1H, *J* = 11.3, 2.9 Hz), 4.27-4.20 (m, 2H), 3.94 (d, 1H, *J* = 5.1), 3.66 (dd, 1H, *J* = 14.9, 8.0 Hz), 3.44 (dd, 1H, *J* = 14.9, 5.4 Hz), 3.30 (d, 2H, *J* = 5.3 Hz), 2.46 (s, 3H), 2.41 (s, 3H). ¹³C NMR (75 MHz, CDCl₃): δ 163.2, 158.6, 145.7, 144.9, 142.3, 134.7, 133.6 (7C_{Ar}), 134.7, 133.6, 130.5, 130.2, 130.0, 128.6, 127.9, 126.1, 121.9, 114.9 (17 CH_{Ar}), 77.9 (CHOTs), 69.7 (CHOH), 69.9, 67.7 (2CH₂OPh), 54.8, 51.8 (2 CH₂N), 22.0, 21.9 (2 CH₃). Anal. Calcd for C₃₂H₃₄N₂O₁₀S₂: C,

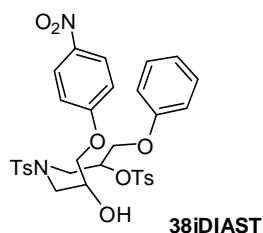

1-(N-(2-hydroxy-3-(4-nitrophenoxy)propyl)-4-methylphenylsulfonamido)-3-phenoxypropan-2-yl 4-methylbenzenesulfonate (38idias)

38idias, yellow wax; [α]_D²⁰ -12.0 (*c* 1.0, CHCl₃). ¹H NMR (300 MHz,

CDCl₃): δ 7.84-7.76 (m, 2H), 7.70-7.66 (m, 2H), 7.36-7.18 (m, 7H), 6.90 (t, 1H, $J = 7.3$ Hz), 6.71-6.66 (m, 2H), 5.21-5.16 (m, 1H), 4.49 (s, 2H), 4.21-4.10 (m, 2H), 4.06-3.95 (m, 1H), 3.55-3.39 (m, 41H), 3.24-3.16 (m, 2H), 2.42 (s, 3H). ¹³C NMR (75 MHz, CDCl₃): δ , 163.2, 158.6, 145.7, 144.9, 142.4, 134.7, 133.6 (7C_{Ar}), 133.6, 130.5, 130.2, 130.0, 128.6, 127.9, 126.2, 121.9, 114.9 (17 CH_{Ar}), 77.9 (CHOTs), 69.7 (CHOH), 69.9, 67.7 (2CH₂O), 54.8, 51.8 (2CH₂N), 22.1, 22.0 (2 CH₃). Anal. Calcd for C₃₃H₃₇NO₈S₂: C, 61.95; H, 5.83; N, 2.19. Found: C,

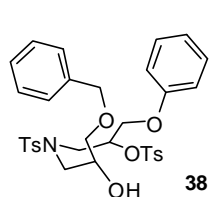

1-(N-(3-(benzyloxy)-2-hydroxypropyl)-4-methylphenylsulfonamido)-3-phenoxypropan-2-yl 4-methylbenzenesulfonate (38l)

38l, yellow wax; $[\alpha]_{\text{D}}^{20} -12.0$ (c 1.0, CHCl₃). ¹H NMR (300 MHz, CDCl₃): δ 7.84-7.76 (m, 2H), 7.70-7.66 (m, 2H), 7.36-7.18 (m, 7H), 6.90 (t, 1H, $J = 7.3$ Hz), 6.71-6.66 (m, 2H), 5.21-5.16 (m, 1H), 4.49 (s, 2H), 4.21-4.10 (m, 2H), 4.06-3.95 (m, 1H), 3.55-3.39 (m, 41H), 3.24-3.16 (m, 2H), 2.42 (s, 3H). ¹³C NMR (75 MHz, CDCl₃): δ , 158.3, 145.4, 144.5, 138.2, 135.0, 133.7 (6C_{Ar}), 130.3, 130.2, 129.8, 128.9, 128.8, 127.5, 128.5, 128.2, 121.8, 114.9 (18 CH_{Ar}), 78.8 (CHOTs), 69.9 (CHOH), 73.8, 72.1, 67.1 (3CH₂O), 54.4, 51.2 (2CH₂N), 22.1, 22.0 (2 CH₃). Anal. Calcd for C₃₃H₃₇NO₈S₂: C, 61.95; H, 5.83; N, 2.19. Found: C,

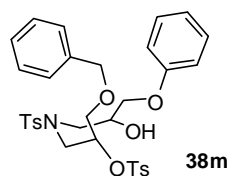

1-(benzyloxy)-3-(N-(2-hydroxy-3-phenoxypropyl)-4-methylphenylsulfonamido) propan-2-yl 4-methylbenzenesulfonate (38m)

38m, wax; $[\alpha]_{\text{D}}^{20} -12.0$ (c 1.0, CHCl₃). ¹H NMR (300 MHz, CDCl₃): δ 7.84-7.76 (m, 2H), 7.70-7.66 (m, 2H), 7.36-7.18 (m, 7H), 6.90 (t, 1H, $J = 7.3$ Hz), 6.71-6.66 (m, 2H), 5.08-5.02 (m, 1H), 4.42 (s, 2H), 4.17-4.02 (m, 2H), 3.92-3.69 (m, 2H), 3.67-3.65 (m, 21H), 3.47-3.33 (m, 3H), 2.42 (s, 3H). ¹³C NMR (75 MHz, CDCl₃): δ , 158.3, 145.4, 144.5, 138.2, 135.0, 133.7 (6C_{Ar}), 130.3, 130.2, 129.8, 128.9, 128.8, 127.5, 128.5, 128.2, 121.8, 114.9 (18 CH_{Ar}), 79.6 (CHOTs), 69.2 (CHOH), 73.8, 69.4, 69.2 (3CH₂O), 54.7, 51.4 (2CH₂N), 22.1, 22.0 (2 CH₃). Anal. Calcd for C₃₃H₃₇NO₈S₂: C, 61.95; H, 5.83; N, 2.19. Found: C,

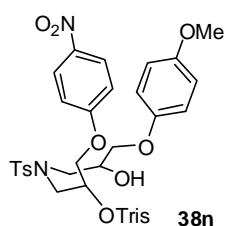

1-(N-(2-hydroxy-3-(4-methoxyphenoxy)propyl)-4-methylphenylsulfonamido)-3-(4-nitrophenoxy)propan-2-yl 2,4,6-triisopropylbenzenesulfonate (38n)

38n, wax; $[\alpha]_{\text{D}}^{20} -12.0$ (c 1.0, CHCl₃). ¹H NMR (300 MHz, CDCl₃): δ ,

8.08-8.02 (m, 2H), 7.72-7.68 (m, 2H), 7.16 (s, 2H), 6.79 (s, 4H), 6.59-6.54 (m, 2H), 5.48-5.42 (m, 1H), 4.40 (dd, 1H, $J = 9.3, 2.1$ Hz), 4.25-4.05 (m, 4H), 3.92 (dd, 1H, $J = 15.3, 2.6$ Hz), 3.86-3.71 (m, 5H), 3.43-3.36 (m, 2H), 2.80 (dd, 1H, $J = 13.8, 6.9$ Hz), 2.43 (s, 3H), 1.28-1.14 (m, 18H). ^{13}C NMR (75 MHz, CDCl_3): δ , 163.2, 154.6, 154.1, 152.7, 150.6, 144.9, 140.6, 134.3(10 C_{Ar}), 130.1, 127.5, 125.7, 123.8, 115.4, 114.7, 114.3 (10 CH_{Ar}), 76.9 (CHOTs), 69.3 (CHOH), 70.2, 67.2 (2 CH_2O), 55.7, 54.4 (CH_2N), 34.3, 29.7, 24.8, 24.4, 23.6 (3CH, 6 CH_3), 21.6, (CH_3). Anal. Calcd for $\text{C}_{41}\text{H}_{52}\text{N}_2\text{O}_{11}\text{S}_2$: C, 60.57; H, 6.45; N, 3.45. Found: C,

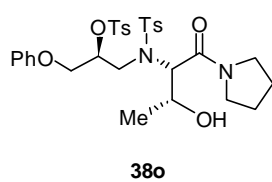

(S)-1-(N-((2S,3R)-3-hydroxy-1-oxo-1-(pyrrolidin-1-yl)butan-2-yl)-4-methylphenylsulfonamido)-3-phenoxypropan-2-yl 4-methylbenzenesulfonate (38o)

38o, wax; $[\alpha]_{\text{D}}^{20} +19.9$ (c 1.0, CHCl_3). ^1H NMR (300 MHz, CDCl_3): δ = 7.84-7.76 (m, 4H), 7.32-7.17 (m, 6H), 6.91 (t, 1H, $J = 7.3$ Hz), 6.69-6.65 (m, 2H), 5.51-5.45 (m, 1H), 4.48 (dd, 1H, $J = 16.5, 8.3$ Hz), 4.28 (d, 1H, $J = 8.5$), 4.13-4.05 (m, 3H), 3.85-3.70 (m, 2H), 3.47-3.21 (m, 3H), 3.11(bs, 1H), 2.41 (s, 3H), 2.38 (s, 3H), 2.08-1.77 (m, 4H), 1.14 (d, 3H, $J = 9.3$). ^{13}C NMR (75 MHz, CDCl_3) δ 167.6 (CO), 157.9, 144.9, 144.1, 135.2, 133.4 (5 C_{Ar}), 129.6, 129.5, 129.3, 128.6, 128.0, 121.1, 114.4 (13 CH_{Ar}), 79.4 (CHOTs), 66.9 (CH_2OPh), 66.0 (OCHPh), 63.4 (CHN), 46.8, 46.1, 45.7 (3 CH_2N), 26.0, 24.0 (2 CH_2), 21.5, 19.0 (3 CH_3). Anal. Calcd for $\text{C}_{31}\text{H}_{38}\text{N}_2\text{O}_8\text{S}_2$: C, 59.03; H, 6.07; N, 4.44. Found: C,

General synthesis of morpholine 36

In a screw cap vial, a heterogeneous mixture of **38** (1 mmol) and TEBA (23 mg, 0.1 mmol) solution in anhydrous MeCN (10 mL), and anhydrous Cs₂CO₃ (0.83 g, 2.5 mmol), was magnetically stirred at 25 °C, then the crude was diluted with DCM (10 mL), filtered through a celite pad. The solvent was evaporated under reduced pressure (RV), and the residue was purified by flash column chromatography on silica gel (230-400 mesh)

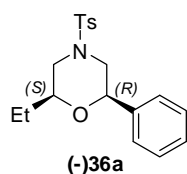

2-ethyl-6-phenyl-4-tosylmorpholine (+)**36a**

white solid y 88%; mp: 119.5-120.2°C; ee >99%; [HPLC: column CHIRALPAK[®] OD; 25 °C; *i*-PrOH/hexane (95:5); flow 0.6 ml/min; [α_D]²⁰: -143.2 (c=1 CHCl₃). ¹H NMR 500 MHz (CDCl₃) δ, 7.78 (d, 2H, Ts, *J* = 8.2 Hz), 7.69 (d, 2H, Ts, *J* = 8.2 Hz), 7.32-7.28 (m, Ts Ph, 9H) 4.95-4.88 (dd, 1H, CHPh, *J* = 3.2, 9.2 Hz), 4.71-4.65 (m, CH₂Et, 1H), 3.53-3.43 (dd, 1H, NCH₂CH₂Et, *J* = 14.8, 5.8 Hz), 3.36-3.23 (m, CH₂NCH₂, 2H), 3.06-2.97 (dd, 1H, NCH₂CHPh *J* = 14.8, 3.2 Hz), 2.42 (s, 6H, CH₃Ts), 1.72-1.52 (m, 2H, CH₂), 0.73 (t, 3H, *J* = 7.3 Hz). ¹³C NMR 300 MHz (CDCl₃) δ, 138.35 (C), 131.72 (C), 129.10 (2CH), 127.75 (2CH), 127.42 (1CH), 127.10 (2CH), 125.30 (2CH), 76.44 (1CH), 76.12 (1CH), 50.99 (1CH₂), 48.86 (1CH₂), 25.63 (1CH₂), 20.84 (1CH₃), 8.98 (1CH₃). Anal. Calcd for C₁₉H₂₃NO₃S: C, 66.06; H, 6.71; N, 4.05. Found

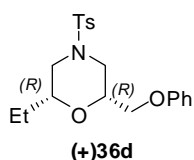

(2R,6R)-2-ethyl-6-(phenoxy)methyl-4-tosylmorpholine (+)**36d**

white solid y 90%; ee >99%; [HPLC: column CHIRALPAK[®] OD; 25 °C; *i*-PrOH/hexane (95:5); flow 0.6 ml/min]; [α_D]²⁰: +78 (c=1 CHCl₃) ¹H NMR 300 MHz (CDCl₃) δ, 7.64 (d, 2H, *J* = 8.1 Hz), 7.35-7.24 (m, 5H), 6.95 (t, 1H, *J* = 7.5 Hz), 6.87 (d, 1H, *J* = 7.8 Hz), 4.05-3.95 (m, 2H), 3.87-3.82 (m, 2H), 3.66-3.3.61 (m, 1H), 3.56-3.53 (m, 1H), 2.44 (s, 3H), 2.18 (t, 1H, *J* = 10.2 Hz), 2.00 (t, 1H, *J* = 10.8 Hz), 1.59-1.36 (m, 2H), 0.94 (t, 3H, *J* = 7.5 Hz). ¹³C NMR 300 MHz (CDCl₃) δ, 159.0 (C), 144.82 (C), 132.89 (C), 130.21 (2CH), 129.89 (2CH), 128.26 (2CH), 121.62 (1CH), 115.01 (2CH), 77.33 (1CH), 74.03 (1CH), 69.23 (1CH₂), 50.46 (1CH₂), 48.90 (1CH₂), 26.89 (1CH₂), 21.96 (1CH₃), 10.03 (1CH₃). Anal. Calcd for C₂₀H₂₅NO₄S: C, 63.97; H, 6.71; N, 3.73. Found

2-(phenoxyethyl)-6-phenyl-4-tosylmorpholine (36e)

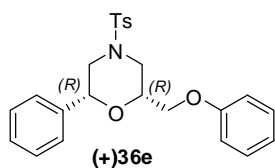

white solid, **11d**, 373 mg, (88%); mp 146-148 °C; AcOEt-hexane 1:4; $[\alpha]_{\text{D}}^{20}$ -31.1 (*c* 1.0, CHCl₃). ee > 99%; HPLC, 4.6/250 mm CHIRALPAK-AD column, 25 °C, *i*-PrOH/hexane (75:25), flow 0.8 ml/min; t_{R} = 11.9 min ¹H NMR (300 MHz, CDCl₃): δ = 7.63 (d, 2H, *J* = 8.2 Hz), 7.44-7.25 (m, 9H), 6.97 (t, 1H, *J* = 7.3 Hz), 6.91 (d, 2H, *J* = 8.2 Hz), 4.73 (dd, 1H, *J* = 10.4, 2.6 Hz), 4.21-4.09 (m, 2H), 3.99-3.96 (m, 2H), 3.83 (dd, 1H, *J* = 11.5, 1.9 Hz), 2.43 (s, 3H), 2.33 (t, 1H, *J* = 11.0 Hz), 2.23 (t, 1H, *J* = 11.0 Hz). ¹³C NMR (75 MHz, CDCl₃): δ = 158.86 (C_{Ar}O), 144.46 (C_{Ar}Me), 138.82 (C_{Ar}), 132.69 (C_{Ar}S), 130.51, 129.97, 128.98, 128.67, 128.29, 126.54, 121.71, 115.17 (14 CH_{Ar}), 78.01 (OCHPh), 74.40 (OCH), 68.78 (CH₂OPh), 52.17 (CH₂N), 48.21 (CH₂N), 22.00 (CH₃). IR (nujol) 1598, 1587, 1493, 1345, 1236, 1167, 1131, 1122, 1065, 1051, 968, 813, 776, 757, 682 cm⁻¹. Anal. Calcd. for C₂₄H₂₅NO₄S: C, 68.06; H, 5.95; N, 3.31. Found: C, 68.10; H, 5.99; N, 3.26.

2-((4-methoxyphenoxy)methyl)-6-((4-nitrophenoxy)methyl)-4-tosylmorpholine (+36f)

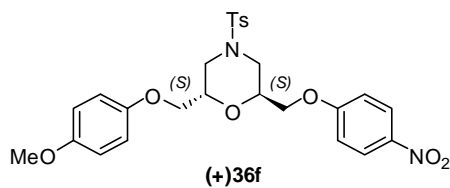

Clare wax, **(+)-36f**, (84%); AcOEt-hexane 1:3; $[\alpha]_{\text{D}}^{20}$ +38.6 (*c* 0.9, CHCl₃). ee > 99. ¹H NMR (300 MHz, CDCl₃): δ , 8.21-8.17 (m, 2H), 7.76-7.63 (m, 2H), 7.35-7.29 (m, 2H), 6.98-6.95 (m, 2H), 6.82 (m, 4H), 4.30-4.12 (m, 5H), 4.01-3.98 (m, 1H), 3.76 (s, 3H), 3.31 (dd, 1H, *J* = 11.7, 3.2 Hz), 3.19 (dd, 1H, *J* = 11.7, 2.4 Hz), 3.11 (dd, 1H, *J* = 11.7, 4.6 Hz), 2.96 (dd, 1H, *J* = 11.7, 6.4 Hz), 2.44 (s, 3H). Anal. Calcd. for C₂₆H₂₈N₂O₈S: C, 59.08; H, 5.34; N, 5.30. Found: C

2-((4-nitrophenoxy)methyl)-6-(phenoxyethyl)-4-tosylmorpholine (36h)

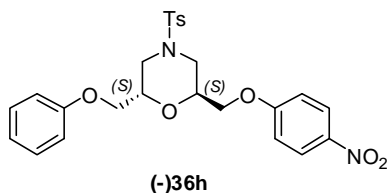

White wax, **3ah**, (88%); AcOEt-hexane 1:2; $[\alpha]_{\text{D}}^{20}$ -35.3 (*c* 1.2, CHCl₃). ee > 99%; ¹H NMR (300 MHz, CDCl₃): δ 8.21-8.17 (m, 2H), 7.67-7.63 (m, 2H), 7.35-7.24 (m, 5H), 7.01-6.87 (m, 4H), 4.31-3.99 (m, 4H), 3.33 (dd, 1H, *J* = 11.5, 3.1 Hz), 2.25-3.12 (m, 2H), 2.98 (dd, 1H, *J* = 11.6, 6.1 Hz), 2.43 (s, 3H). ¹³C NMR (75 MHz, CDCl₃): δ 163.6, 148.7, 144.7, 142.4, 132.5 (5C_{Ar}), 130.4, 130.0, 128.3, 127.5, 121.9, 105.6 (13 CH_{Ar}), 69.7, 69.5 (2CHO), 678.6, 67.2

(2CH₂O), 47.7, 47.4(2CH₂N), 22.00 (CH₃). Anal. Calcd. for C₂₄H₂₅NO₄S: C, 68.06; H, 5.95; N, 3.31. Found: C,

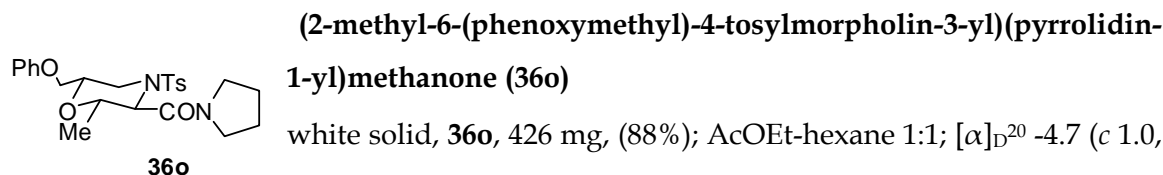

white solid, **36o**, 426 mg, (88%); AcOEt-hexane 1:1; [α]_D²⁰ -4.7 (*c* 1.0, CHCl₃). ee > 99. ¹H NMR (300 MHz, CDCl₃): δ = 7.82-7.79 (m, 2H), 7.30-7.22 (m, 4H), 6.94 (t, 1H, *J* = 7.3 Hz), 6.85-6.83 (m, 2H), 4.12-43.90 (m, 4H), 3.74 (t, 2H, *J* = 6.6 Hz), 3.65-3.60 (m, 2H), 3.46 (t, 2H, *J* = 6.9 Hz), 2.85 (dd, 1H, *J* = 11.8, 17.5 Hz), 2.40 (s, 3H), 2.04-1.83 (m, 4H), 1.23 (d, 1H, *J* = 6.2Hz). ¹³C NMR-APT (75 MHz, CDCl₃): δ , 167.2 (CO), 158.3, 144.0, 134.2 (3C_{Ar}), 129.5, 129.4, 128.3, 121.2, 114.6 (9 CH_{Ar}), 73.6, 72.9 (2 OCH), 68.3 (CH₂O), 63.3 (1CHN), 47.2, 46.6, 46.1 (3CH₂N), 26.1, 23.9 (2CH₂), 21.5, 17.9 (2CH₃). Anal. Calcd. for C₂₄H₃₀N₂O₅S: C, 62.86; H, 6.59; N, 6.11. Found: C,

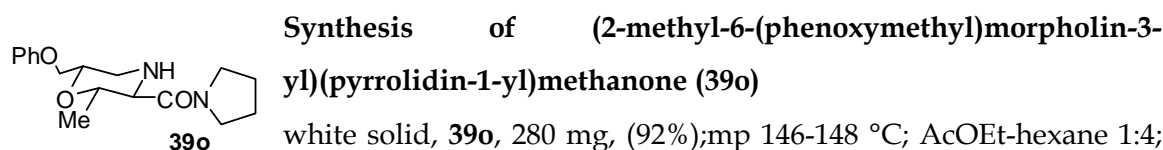

white solid, **39o**, 280 mg, (92%); mp 146-148 °C; AcOEt-hexane 1:4; [α]_D²⁰ +8.3 (*c* 0.8, CHCl₃). ee > 99%; (300 MHz, CDCl₃): δ , 7.27-7.21 (m, 2H), 6.94-6.84 (m, 2H), 4.0-3.92 (m, 1H), 3.88-3.83 (m, 2H), 3.74-3.65 (m, 2H), 3.51-3.42 (m, 2 H), 3.35 (d, 1H, *J* = 9.1 Hz), 3.15 (bs, 1H), 3.12 (dd, 1H, *J* = 15.6, 1.6 Hz), 2.72 (dd, 1H, *J* = 15.6, 12.0 Hz), 2.01-1.80 (m, 4H), 1.16 (d, 2H, *J* = 6.2). ¹³C NMR (75 MHz, CDCl₃): δ , 169.2 (CO), 158.7 (C_{Ar}), 129.4, 120.9, 114.5 (3CH_{Ar}), 75.8, 75.4 (2OCH), 69.1 (NCH), 46.8, 46.4, 45.8 (3CH₂N), 24.2, 22.6 (2CH₂), 18.1 (CH₃). Anal. Calcd. for C₂₄H₃₀N₂O₅S: C, 62.86; H, 6.59; N, 6.11. Found: C,

Synthesis of N-(2,2-diethoxyethyl)-4-methylbenzenesulfonamide (**41**)

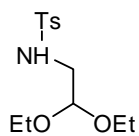

A heterogeneous mixture of TsNH₂ (342 mg, 2 mmol), TEBA (23 mg, 0.1 mmol) and bromoacetale (1 mmol) solution in anhydrous acetonitrile (0.5 mL), anhydrous K₂CO₃ (14 mg, 1 mmol) and KI (1 mmol), was magnetically stirred at 90 °C for 3 days. After cooling, the crude product was diluted with DCM (10 mL), filtered through celite, the solvent was evaporated under reduced pressure and the residue was purified by flash column chromatography on silica gel (230-400 mesh).

41, 216 mg, (75%); white solid, mp 62-66.2 °C; AcOEt-hexane 2:1. ¹H NMR (300 MHz, CDCl₃): δ 7.765-7.72 (m, 2H), 7.33-7.26 (m, 2H), 4.63 (t, 1H, *J* = 5.6 Hz), 3.69-3.39 (m, 4H), 3.03 (t, 1H, *J* = 5.6 Hz), 2.43 (s, 3H), 1.17 (t, 1H, *J* = 10.6 Hz).

General synthesis of *N*-tosyl amido alcohol **42**

A heterogeneous mixture of tosylamido derivative **31** (1.4 mmol), TEBA (23 mg, 0.1 mmol), epoxide (1 mmol) solution in anhydrous dioxane (1.5 mL) and anhydrous alkaline carbonate (0.1 mmol), was magnetically stirred at 90 °C until no starting material **1** was detectable (TLC analysis). After the usual workup, the residue was purified by flash column chromatography on silica gel (230-400 mesh).

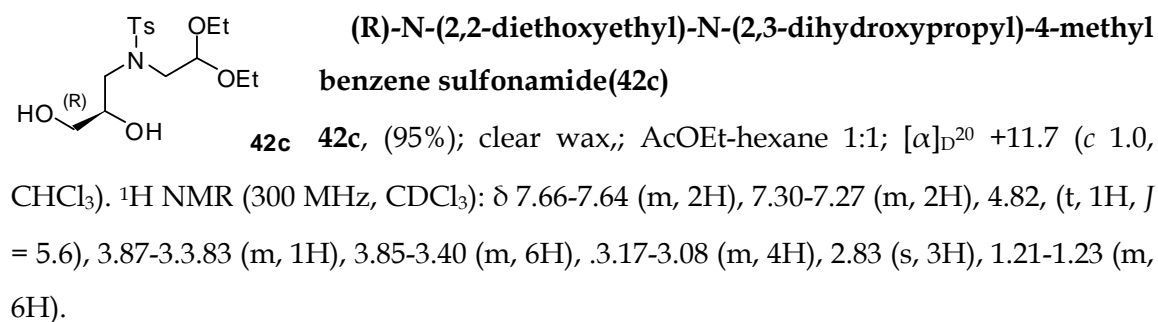
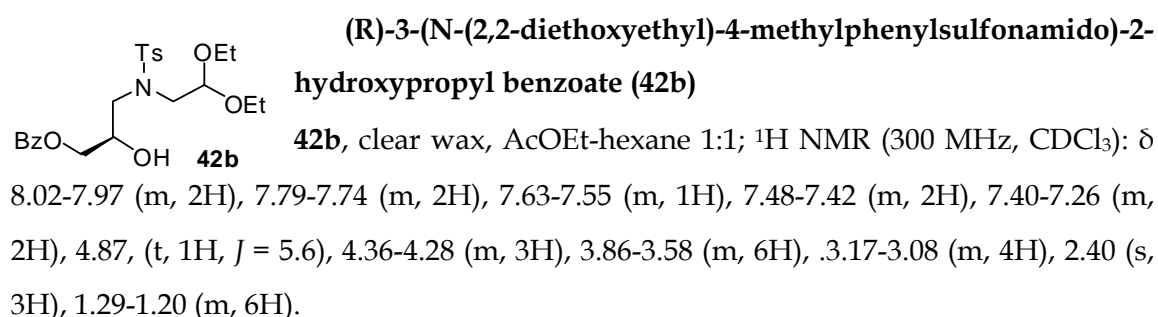
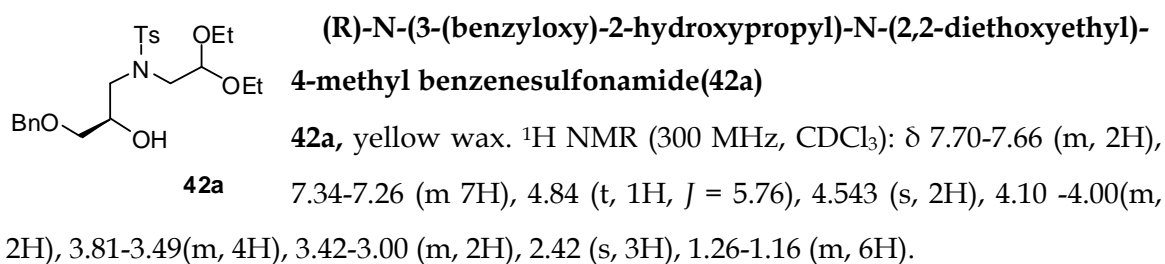

General synthesis of hydroxyl morpholines 43

To a solution of tosyl amido alcohol **42** (1mmol) in acetone_{aq} (...ml) was added paratoluen sulfonic acid (0.2 mmol). The solution was stirred at reflux until no starting material **42** was detectable (TLC analysis). The solvent was evaporated under reduced pressure (RV), and then, the residue was diluted with dichloro methane and washed with NaHCO_{3sat.} After dried on MgSO₄, the solvent was evaporated under reduced pressure (RV), and the crude was purified by FCC on silica gel.

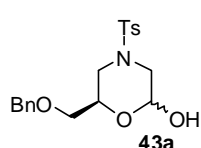

(R)-6-(benzyloxymethyl)-4-tosylmorpholin-2-ol(43a)

43a, yellow wax, 66%. Diastereoisomeric mixture. ¹H NMR (300 MHz, CDCl₃): δ 7.62-7.56 (m, 2+2H), 7.36-7.22 (m 7+7H), 5.16 (m, 1H), 4.83 (dd, 1H, *J* = 12.9, 3.8), 4.48 (s, 2+2H), 4.44-4.27 (m, 1H), 3.91-3.83 (m, 1H), 3.70-3.39 (m, 3+3H), 2.51(dd, 1H, *J* = 11.8, 2.4) 2.43 (s, 3H), 2.35 (t, 1H, *J* = 10.8), 2.12-2.01 (m, 2H).

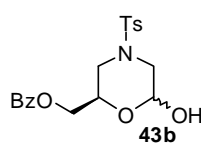

(R)-(6-hydroxy-4-tosylmorpholin-2-yl)methyl benzoate(43b)

44b, yellow wax, Diastereoisomeric mixture. ¹H NMR (300 MHz, CDCl₃): δ 7.62-7.56 (m, 2+2H), 7.36-7.22 (m 7+7H), 5.16 (m, 1H), 4.83 (dd, 1H, *J* = 12.9, 3.8), 4.48 (s, 2+2H), 4.44-4.27 (m, 1H), 3.91-3.83 (m, 1H), 3.70-3.39 (m, 2H), 2.51(dd, 1H, *J* = 11.8, 2.4) 2.43 (s, 3H), 2.35 (t, 1H, *J* = 10.8), 2.12-2.01 (m, 2H).

General synthesis of morpholines **44**

To a suspension of morpholine **43** (1 mmol) in dry dichloromethane (4 mL), TEA (1.1 mmol) and DMAP (0.1 mmol) was added at 25 °C. After cooling at 0 °C, benzoyl chloride (1.5 mmol) was added dropwise and the resulting solution was stirred until no starting material was detectable by TLC. The solution was then diluted with dichloromethane (20 mL), washed with saturated NH₄Cl solution (2×15 mL), saturated NaHCO₃ solution (2×15 mL), and brine (20 mL), dried over MgSO₄ and filtered. After evaporation of the solvent under vacuum (RV), the crude was purified by FCC to afford product **44**. Yields, chromatographic eluants, physical and analytical data are as follows.

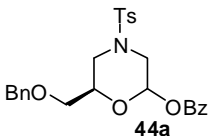
(6R)-6-(benzyloxymethyl)-4-tosylmorpholin-2-yl benzoate(44a)
**44a** **44b** (91%), yellow wax. Diastereoisomeric mixture. ¹H NMR (300 MHz, CDCl₃): δ 8.03-7.94 (m, 2+2H), 7.0-7.25 (m 12+12H), 6.12 (s, 1H), 5.79 (dd, 1H, *J* = 7.1, 2.7), 4.50 (d, 2H, *J* = 1.8), 4.17-3.96 (m, 1+1H), 3.65-3.65 (m, 2H), 3.53-3.50 (m, 2H), 2.43 (s, 3+3H).

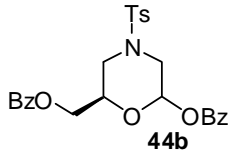
((2R)-6-(benzyloxy)-4-tosylmorpholin-2-yl)methyl benzoate(44b)
**44b**, yellow wax, Diastereoisomeric mixture. ¹H NMR (300 MHz, CDCl₃): δ 8.03-7.94 (m, 2+2H), 7.0-7.25 (m 12+12H), 6.37 (s, 1H), 6.16 (dd, 1H, *J* = 7.1, 2.7), 4.46-4.22 (m, 3+3H), 3.85-3.46 (m, 2+3H), 3.87-3.44 (m, 2+1H), 2.43 (s, 3H), 2.39, (s, 3H).

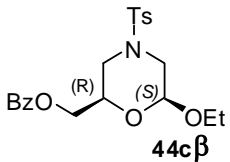
(R)-(6-ethoxy-4-tosylmorpholin-2-yl)methyl benzoate(44cβ)
**44cβ**, AcOEt-hexane 2:1; [α]_D²⁰ +11.2 (*c* 1.0, CHCl₃). ¹H NMR (300 MHz, CDCl₃): δ 8.20-7.99 (m, 2H), 7.64-7.61 (m 2H), 7.61-7.55 (m, 1H), 7.46-7.41 (m, 2H) 7.33-7.30 (m, 2H) 4.67 (dd, 1H, *J* = 8.4, 2.4), 4.41 (dd, 1H, *J* = 11.4, 5.4), 4.28 (dd, 1H, *J* = 11.4, 5.7), 4.08-4.00 (m, 1H), 3.96-3.85 (m, 1H), 3.71 (d, 2H, *J* = 11.7), 2.42 (s, 3H), 2.28-2.15 (m, 2H), 1.99 (t, 3H, *J* = 7.2). ¹³C NMR (75 MHz, CDCl₃): δ, 166.6 (1CO), 144.1, 132.2 (2C_{ar}), 133.2, 129.8, 128.5, 129.7, 128.4, 127.8 (9CH_{ar}), 98.2 (OCHO), 71.3, 64.3 (2OCH₂), 65.0 (1CH), 49.0, 47.0 (2 NCH₂), 21.5, 15.1 (2CH₃).

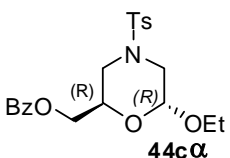
(R)-(6-ethoxy-4-tosylmorpholin-2-yl)methyl benzoate(44cα)
**44cα**

44ca. AcOEt-hexane 2:1; $[\alpha]_D^{20}$ -11.3 (*c* 1.0, CHCl₃). ¹H NMR (300 MHz, CDCl₃): δ 8.04-7.98 (m, 2H), 7.67-7.64 (m 2H), 7.59-7.54 (m, 1H), 7.46-7.41 (m, 2H) 7.32-7.29 (m, 2H) 4.83 (d, 1H, *J* = 1.8), 4.38-4.24 (m, 3H), 3.76-3.45 (m, 4H), 2.66 (dd, 1H, *J* = 11.8, 2.4), 2.51(dd, 1H, *J* = 12.0, 2.7) 2.49 (t, 1H, *J* = 10.5), 2.35 (t, 1H, *J* = 10.8), 2.42 (s, 3H), 1.98 (t, 3H, *J* = 7.2). ¹³C NMR (75 MHz, CDCl₃): δ , 194.4 (1CO), 166.0, 143.8 (2C_{ar}), 133.2, 129.7, 128.5, 128.4, 127.9 (9CH_{ar}), 94.3 (OCHO), 65.6, 64.5 (2OCH₂), 63.2 (1CH), 48.2, 46.8 (2 NCH₂), 21.5, 15.0 (2CH₃).

General procedure for the Lewis acid promoted addition of nucleic bases 45,47

To a mixture of adenine in acetonitrile is added a solution of morpholine **44c** (23.61 mmol) in anhydrous acetonitrile (30 ml). The stirred reaction mixture is finally treated with the Lewis acid (24.28 mmol) at 0°C. After complete addition, the reaction mixture was stirred at room temperature for 20h.

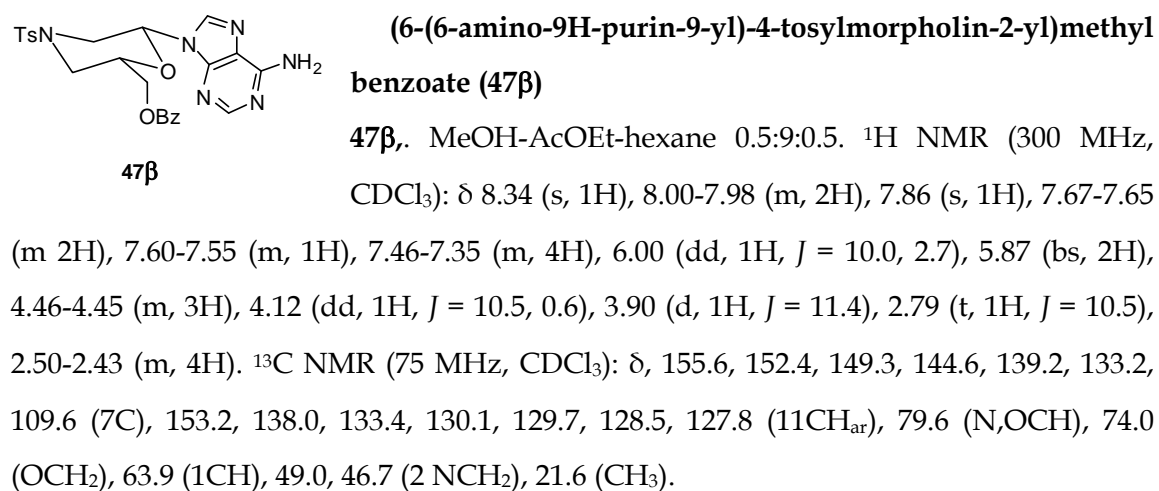
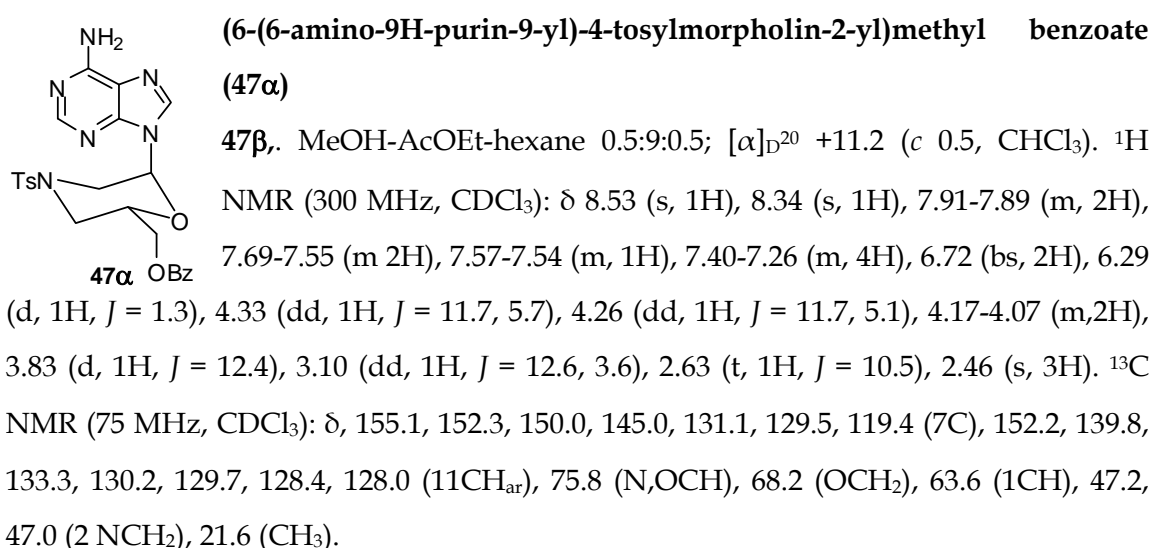
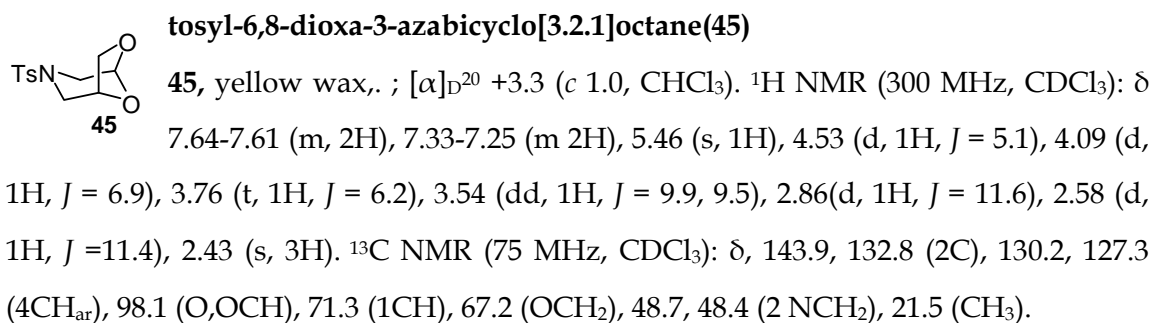

Syntheses of (6-(5-fluoro-2,4-dioxo-3,4-dihydropyrimidin-1(2H)-yl)-4-tosylmorpholin-2-yl)methyl benzoate (**48β**)

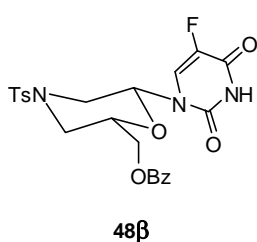

A mixture of 5-chlorouracil (68.24 mmol), HMDS (89.75 mmol) and saccharine (50 mg) was refluxed in anhydrous acetonitrile (20 ml) for 3 hr to get a clear solution. Excess solvent was removed by evaporation under vacuum. A solution of morpholine **44c** (23.61 mmol) in anhydrous acetonitrile (30 ml) was then added to the silylated base. The reaction mixture was then cooled to 0°C in an ice bath. The stirred, cooled reaction mixture was finally treated dropwise with TMStriflate (24.28 mmol) in anhydrous acetonitrile (3.0 ml). After complete addition, the reaction mixture was stirred at room temperature for 20h.

47β, AcOEt-hexane 9.5:0.5. ¹H NMR (300 MHz, CDCl₃): δ 9.13 (d, 1H, *J* = 4.5), 7.93-7.91 (m, 3H), 7.50-7.26 (m 5H), 5.72 (dd, 1H, *J* = 9.0, 1.5), 4.31-4.30 (m, 2H), 4.18-4.14 (m, 1H), 3.82 (dd, 1H, *J* = 11.4, 0.9), 3.73 (d, 1H, *J* = 11.7), 2.38 (s, 3H), 2.23 (t, 1H, *J* = 11.2), 2.13 (t, 1H, *J* = 11.1).

