

Photocatalyzed, C-5 selective functionalization of β -fucosides via HAT mechanisms

Lorenzo Favier¹, Elena Cassera², Maurizio Fagnoni², Davide Ravelli², Anna Bernardi¹, Sarah Mazzotta¹

¹Dipartimento di Chimica, Università degli Studi di Milano, Via Golgi 19, 20133 Milan, Italy;

²Department of Chemistry, University of Pavia, Viale Taramelli 12, 27100 Pavia, Italy.

Selectivity is key!

Sugar scaffolds' functionalization plays a pivotal role in drug development.

C-H bond activation via Hydrogen Atom Transfer (HAT) reactions represents an important tool for the direct modification of the sugar backbone. However, achieving full regio- and stereoselectivity still proves challenging.

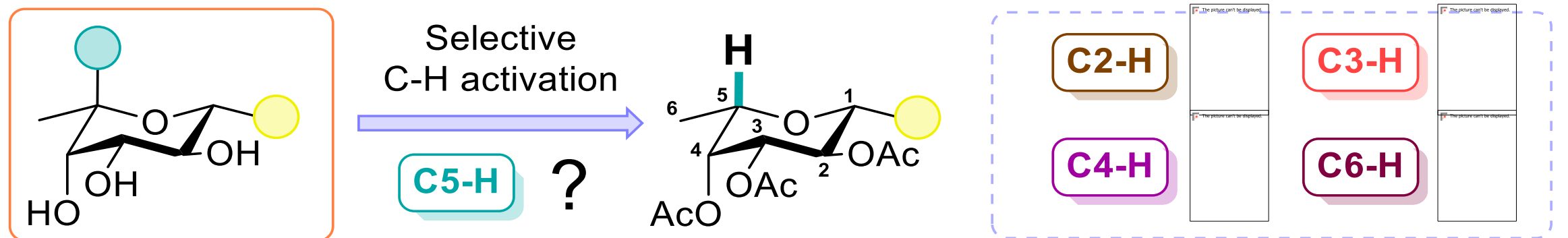

What started it all!

In our research for the development of glycomimetics for fucoside-specific receptors, we designed a regio- and stereoselective photocatalyzed functionalization of β -fucosides.

This is achieved using TBADT as a direct photocatalyst; the sugar radical intermediate may undergo Giese-like alkylation with an electron-poor olefin.

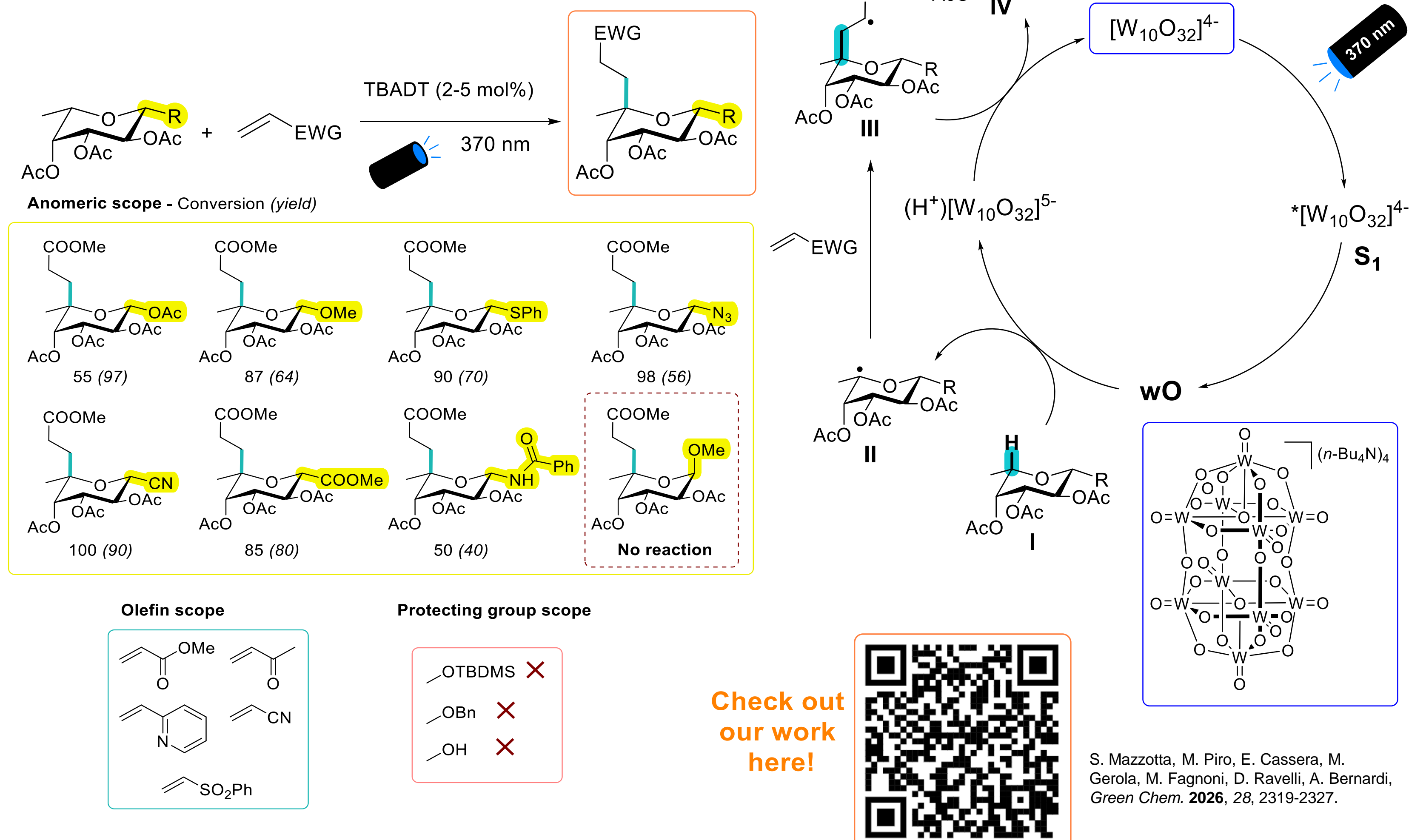

Stay tuned for more – fucoside fluorination!

β -fucosides show very interesting reactivity in HAT reactions.

Fluorine may be extremely versatile in the glycomimetic world – it can alter the interactions of sugars with their receptors or serve as an NMR tag for monitoring.

Here we show the direct C5-selective axial fluorination of β -fucosides via an electrophilic fluorine source.

Anomeric scope - Conversion (yield)

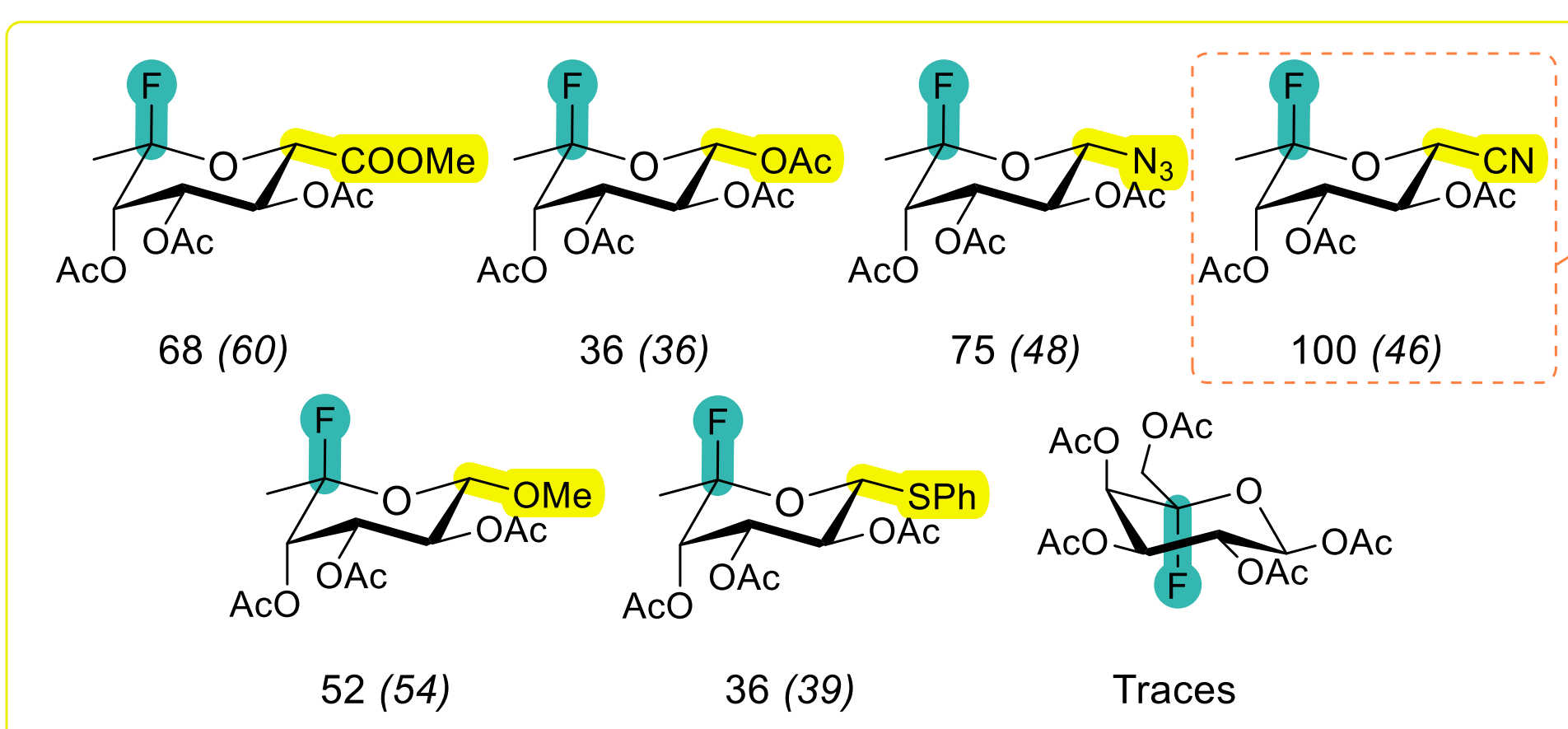

The reaction mechanism, although believed to be similar to the one of the Giese alkylation, will be studied via kinetic experiments and computational calculations.

Let's keep in touch!

Lorenzo Favier

PhD Student in Chemistry (XL cycle)
Università degli Studi di Milano, Italy
lorenzo.favier@unimi.it



Società
Chimica
Italiana

